

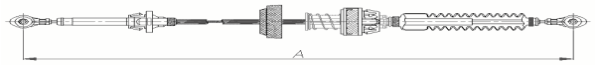

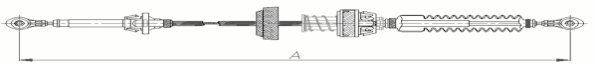

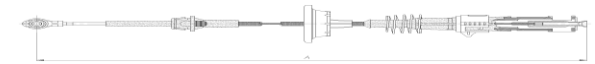

Automóvil - Suv - Van - Pickup - Camiones Pesados - Ligeros

IMPORTANTE. Evite devoluciones o reclamos. Identifique previamente: marca, modelo y año del vehículo. En caso de duda, **CONSULTE** a su asesor.

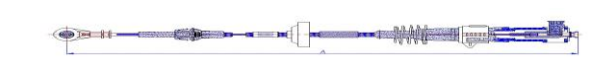
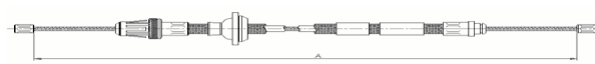
NUESTRA MISIÓN... Ser su aliado en el desarrollo y crecimiento de su negocio

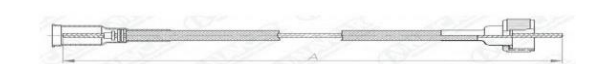
Competimos directamente con los ORIGINALES

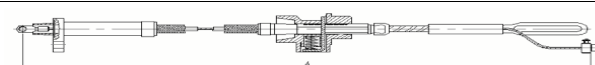
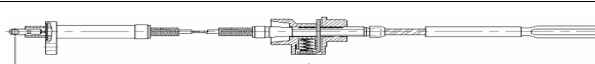





LINEA	CODIGO	MODELO	MOTOR	O.E.M	ARMADO	IMAGEN -- LONGITUD
BUICK						
BUICK - CENTURY						
CONJUNTO SELECTOR CAMBIOS	3455 GMCS	Century 2002-2007 T/Automática	0	12458109	SC59	 2889mm
SELECTOR CAMBIOS	2521 GMCS	Century THM125 1986 - 1990 T/Automática	V6 Cil. 3.8 L	10038609	SC29	 1432mm
	3416 GMCS	Century 1986-1996 T/Automática	V6 Cil. 3.8 L	12552510	SC29	 1504mm
	3446 GMCS	Century 2002-2007 T/Automática	V6 Cil. 3.1 L	15873762	SC58 Tramo Superior	 1872mm
	3449 GMCS	Century 2002-2007 T/Automática	V6 Cil. 3.1 L	15873759	SC57 Tramo Inferior	 1024mm
	3454 GMCS	Century 2002-2007 T/Automática	V6 Cil. 3.1 L	15952338	SC63 Tramo Superior	 1222mm
FRENO DE MANO	2806 GMCFP	Century 1977 - 2001	V6 Cil. 3.1 L	10306507	FP288 Principal	 2990mm
LIBERADOR FRENO	934 ECEP	Century 1982...	L4 Cil. 2.5 L	14049336	LF1	 205mm
VELOCIMETRO	2006 GMVCU	Century 1980	V6 Cil. 3.8 L	6480239 25032875	VZ79	 2540mm
	2695 GMVCZ	Century 1980-1983	V6 Cil. 3.8 L	25033114 25033168	VZ89	 527mm
SOBREMARCHA	1656 SBUN	Century THM 350 1977 - 1980	0	Código Universal K35951U	SB24	 1096mm
	1820 GMCSB	Century TH-350 1977 - 1979	V6 Cil. 3.8 L	1262622	SB3	 950mm

Automóvil - Suv - Van - Pickup - Camiones Pesados - Ligeros

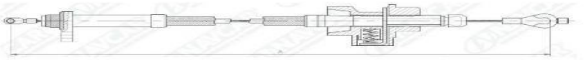
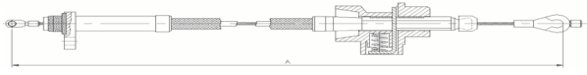
IMPORTANTE. Evite devoluciones o reclamos. Identifique previamente: marca, modelo y año del vehículo. En caso de duda, **CONSULTE** a su asesor.

NUESTRA MISIÓN... Ser su aliado en el desarrollo y crecimiento de su negocio

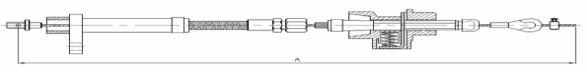
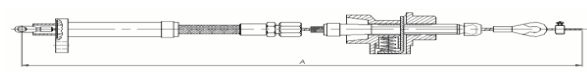
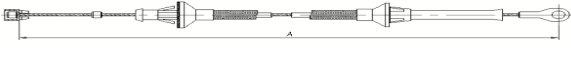
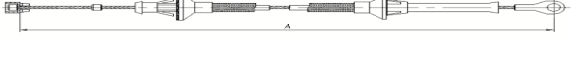
Competimos directamente con los ORIGINALES









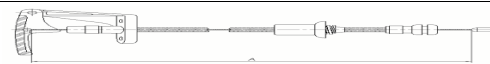

LINEA	CODIGO	MODELO	MOTOR	O.E.M	ARMADO	IMAGEN -- LONGITUD
SOBREMARCHA	1507 GMSB	Century TH-440-T4 1986	V6 Cil. 3.8 L	25508262	SB2	 894mm
	1506 GMSB	Century TH-350 1981	V6 Cil. 3.8 L	25503382	SB19	 968mm
	1508 GMSB	Century TH-350 1981	0	25507541	SB19	 928mm
	1620 GMSB	Century THM 200C 1981	0	25507550	SB2	 911mm
	1658 GMSB	Century THM125C 1982 - 1983	0	25513389	SB2	 607mm
	1659 GMSB	Century THM125C 1982 - 1983	0	25513393	SB2	 1035mm
	2289 GMCSB	Century THM125C 1982-1985	0	25510971	SB2	 776mm
	1367 SBUN	Century 1982 - 1987	0	0	SB18	 1255mm
	1368 SBUN	Century TH-350 1977 - 1982	0	0	SB17	 1110mm
ACELERADOR	353 ECAA	Century 1975...	V8 Cil. 5.7 L	1252955	AC1	 521mm
	1539 GMCA	Century 1978 - 1980	V6 Cil. 3.8 L	1254180	AC1	 590mm
	3567 GMCAC	Century 1997 - 1999	V6 Cil. 3.1 L	12557988	AC254	 1646mm
ACELERADOR	3450 GMCAC	Century 1998 - 2004	V6 Cil. 3.1 L	10332800	AC254	 1586mm

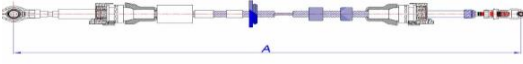
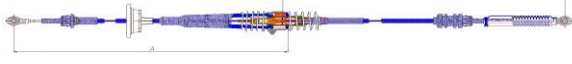
Automóvil - Suv - Van - Pickup - Camiones Pesados - Ligeros

IMPORTANTE. Evite devoluciones o reclamos. Identifique previamente: marca, modelo y año del vehículo. En caso de duda, **CONSULTE** a su asesor.

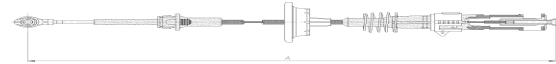
NUESTRA MISIÓN... Ser su aliado en el desarrollo y crecimiento de su negocio

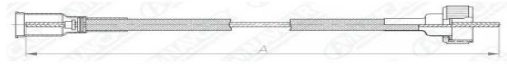
Competimos directamente con los ORIGINALES

LINEA	CODIGO	MODELO	MOTOR	O.E.M	ARMADO	IMAGEN -- LONGITUD
	3559 GMCAC	Century 2000-2005	V6 Cil. 3.1 L	12567430	AC255	 1651mm
APERTURA COFRE	1444 CHEC	Century	V6 Cil. 3.1 L	10270780	CP16	 2020mm
BUICK - ELECTRA						
SOBREMARCHA	1614 GMSB	Electra THM200, THM200-4R, THM250 1983-1985	0	25515164	SB2	 867mm
BUICK - ENCLAVE						
SELECTOR CAMBIOS	4229 GMSCS	Buick Enclave 2008-2017	6 Cil 3.6L	23256076	SC137	 1586mm
BUICK - LACROSSE /ALLURE						
CONJUNTO SELECTOR CAMBIOS	3455 GMSCS	LaCrosse /Allure 2002-2007 T/Automática	0	12458109	SC59	 2889mm
SELECTOR CAMBIOS	3454 GMSCS	LaCrosse /Allure 2002-2007 T/Automática	V6 Cil. 3.1 L	15952338	SC63 Tramo Superior	 1222mm
	3446 GMSCS	LaCrosse /Allure 2002-2007 T/Automática	V6 Cil. 3.1 L	15873762	SC58 Tramo Superior	 1872mm
	3449 GMSCS	LaCrosse /Allure 2002-2007 T/Automática	V6 Cil. 3.1 L	15873759	SC57 Tramo Inferior	 1024mm
	3453 GMSCS	LaCrosse /Allure 2005-2006 T/Automática	V6 Cil. 3.6 L	15873760	SC58 Tramo Superior	 1223mm
	3452 GMSCS	LaCrosse /Allure 2007 - 2011 T/Automática	V6 Cil. 3.6 L	25940463	SC57 Tramo Inferior	 1020mm
BUICK - LESABRE						
VELOCIMETRO	2168 GMCVU	Lesabre 1975	0	6478169 25032082	VZ79	 1042mm
SOBREMARCHA	2290 GMCSCB	Lesabre 1980	4.3 5.0 5.7	25503382	SB19	 960mm

Encino 1287 col. del Fresno Guadalajara Jal.

Automóvil - Suv - Van - Pickup - Camiones Pesados - Ligeros





IMPORTANTE. Evite devoluciones o reclamos. Identifique previamente: marca, modelo y año del vehículo. En caso de duda, **CONSULTE** a su asesor.

NUESTRA MISIÓN... Ser su aliado en el desarrollo y crecimiento de su negocio



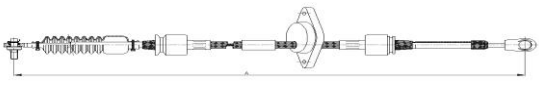



Competimos directamente con los ORIGINALES

LINEA	CODIGO	MODELO	MOTOR	O.E.M	ARMADO	IMAGEN -- LONGITUD
-------	--------	--------	-------	-------	--------	--------------------

BUICK - LUCERNE

SELECTOR CAMBIOS	3643 GMCS	Lucerne 2000 - 2005 T/Automática	V6 Cil. 3.8 L	15774350	SC68	 2072mm
	3417 GMCS	Lucerne 2001-2008 T/Automática	V8 Cil. 4.6 L V6 Cil. 3.8 L	25838820	SC62	 2176mm
	3451 GMCS	Lucerne CX 2009 - 2011 T/Automática	V6 Cil. 3.9 L	25820019 25906455	SC62	 2153mm
FRENO DE MANO	3728 GMCFP	Lucerne 2007	V8 Cil. 4.6 L	15860089	FP360 Trasero Derecho	 2954mm
	3729 GMCFP	Lucerne 2007	V8 Cil. 4.6 L	15825148	FP361 Trasero Izquierdo	 1855mm

BUICK - REGAL









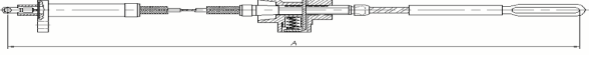
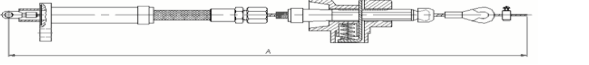

CONJUNTO SELECTOR CAMBIOS	3455 GMCS	Regal 2002-2007 T/Automática	0	12458109	SC59	 2889mm
SELECTOR CAMBIOS	3454 GMCS	Regal 2002-2007 T/Automática	V6 Cil. 3.1 L	15952338	SC63 Tramo Superior	 1222mm
	3446 GMCS	Regal 2002-2007 T/Automática	V6 Cil. 3.1 L	15873762	SC58 Tramo Superior	 1872mm
	3449 GMCS	Regal 2002-2007 T/Automática	V6 Cil. 3.1 L	15873759	SC57 Tramo Inferior	 1024mm
	2152 GMCS	Regal Limited 1994 - 1996 T/Automática	V6 Cil. 3.1 L 3.8 L	12553934	SC32	 1890mm
	2496 GMCS	Regal THM200-4R 1983-1988 T/Automática	0	2251949	SC5	 653mm
FRENO DE MANO	2806 GMCFP	Regal 1977 - 2001	V6 Cil. 3.1 L	10306507	FP288 Principal	 2990mm

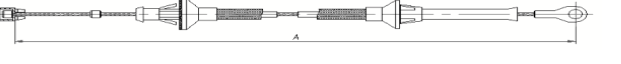
Automóvil - Suv - Van - Pickup - Camiones Pesados - Ligeros

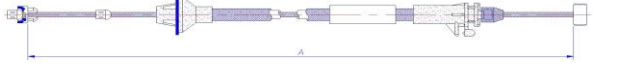
IMPORTANTE. Evite devoluciones o reclamos. Identifique previamente: marca, modelo y año del vehículo. En caso de duda, **CONSULTE** a su asesor.

NUESTRA MISIÓN... Ser su aliado en el desarrollo y crecimiento de su negocio

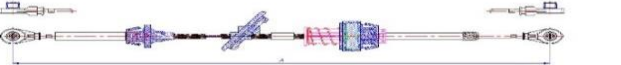
Competimos directamente con los ORIGINALES



LINEA	CODIGO	MODELO	MOTOR	O.E.M	ARMADO	IMAGEN -- LONGITUD
FRENO DE MANO	2805 GMCFP	Regal 1996 - 1997	V6 Cil. 3.8 L 3.1 L	10287296	FP240 Trasero Izquierdo	 2115mm
SOBREMARCHA	1820 GMCSB	Regal TH-350 1977 - 1979	V6 Cil. 3.8 L	1262622	SB3	 950mm
	1368 SBUN	Regal 1978 - 1980	0	0	SB17	 1110mm
VELOCIMETRO	2695 GMCVZ	Regal 1980-1983	V6 Cil. 3.8 L	25033114 25033168	VZ89	 527mm
ACELERADOR	1539 GMCA	Regal 1978 - 1980	V6 Cil. 3.8 L	1254180	AC1	 590mm
	3601 GMCAC	Regal 1981-1982	V8 Cil. 4.9 L	1244463 1254179	AC263	 507mm
	3448 GMCAC	Regal 1993-1995	V6 Cil. 3.8 L 3.1 L	12554626	AC249	 943mm
	3567 GMCAC	Regal 1997 - 1999	V6 Cil. 3.1 L	12557988	AC254	 1646mm
	3450 GMCAC	Regal 1998 - 2004	V6 Cil. 3.1 L	10332800	AC254	 1586mm
	3559 GMCAC	Regal 2000-2005	V6 Cil. 3.1 L	12567430	AC255	 1651mm
	BUICK - RENDEZVOUZ					
SELECTOR CAMBIOS	3814 GMCSB	Rendezvous 2001-2009 T/Automática	V6 Cil. 3.6 L	103400403 12565602 15299671	SC70	 1558mm
BUICK - SKYLARK						
	1761 GMCSB	SkyLark 1983 - 1985 T/Automática	L4 Cil. 2.5 L	10041214	SC12	 1384mm

Automóvil - Suv - Van - Pickup - Camiones Pesados - Ligeros

IMPORTANTE. Evite devoluciones o reclamos. Identifique previamente: marca, modelo y año del vehículo. En caso de duda, **CONSULTE** a su asesor.

NUESTRA MISIÓN... Ser su aliado en el desarrollo y crecimiento de su negocio

Competimos directamente con los ORIGINALES

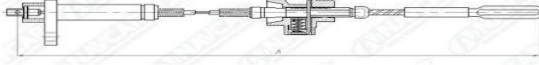
LINEA	CODIGO	MODELO	MOTOR	O.E.M	ARMADO	IMAGEN -- LONGITUD
SELECTOR CAMBIOS	1767 GMCSC	Skyhawk THM125C 1987 - 1989 T/Automática	L4 Cil. 2.0 L	10034333	SC15	 1278mm
	3776 GMCSC	Skylark 1981 T/Automática	0	10017823	SC76	 1273mm
SOBREMARCHA	1611 GMSB	Skylark THM200 1977	0	1253966	SB20	 894mm



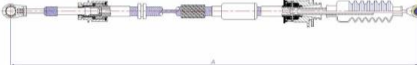

BMW

MINI COOPER

NEUTRAL CAMBIOS	4222 BMWSC	Mini Cooper 2011-2014	0	25117604434	SC134	 1299mm
SELECTOR CAMBIOS	4223 BMWCC	Mini Cooper 2011-2014	0	25117604437	CC113	 1383mm

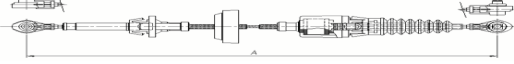
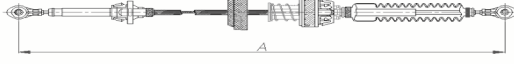
CADILLAC

CADILLAC - DEVILLE

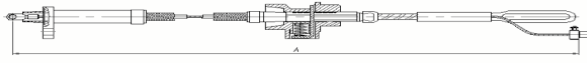



SELECTOR CAMBIOS	2041 GMCSC	Deville 1985 - 1992 T/Automática	V8 Cil. 4.5 L	25524872	SC12	 1474mm
	3097 GMCSC	Deville 1986-1993 T/Automática	V8 Cil. 4.5 L	25527523	SC29	 1352mm
	3643 GMCSC	Deville 2000 - 2005 T/Automática	V8 Cil. 4.5 L	15774350	SC68	 2072mm
	3417 GMCSC	Deville 2001-2008 T/Automática	V8 Cil. 4.5 L	25838820	SC62	 2176mm
ACELERADOR	3931 GMCAC	Deville 1996-2002	V8 Cil. 4.6 L	3545150	AC155	 984mm
SOBREMARCHA	1656 SBUN	Deville THM 350 1980 - 1984	0	Código Universal K35951U	SB24	 1096mm

Automóvil - Suv - Van - Pickup - Camiones Pesados - Ligeros

¡IMPORTANTE! Evite devoluciones o reclamos. Identifique previamente: marca, modelo y año del vehículo. En caso de duda, **CONSULTE** a su asesor.

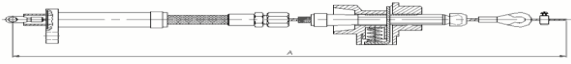
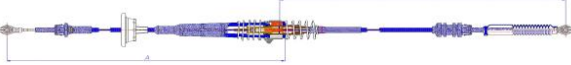
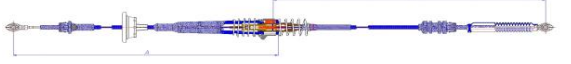
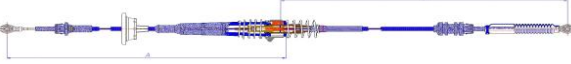
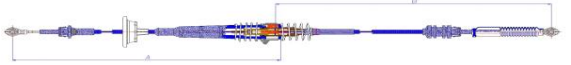
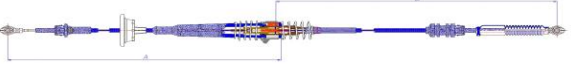
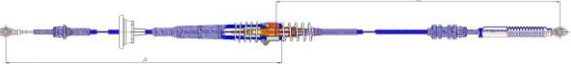
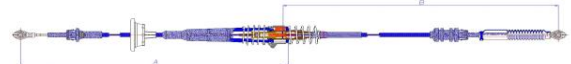
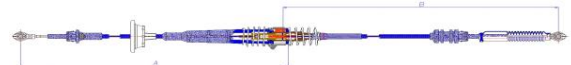
NUESTRA MISIÓN... Ser su aliado en el desarrollo y crecimiento de su negocio

Competimos directamente con los ORIGINALES

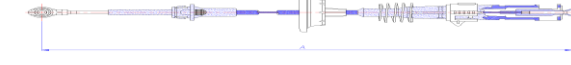
LINEA UNIV.	CODIGO	MODELO	MOTOR	O.E.M	ARMADO	IMAGEN -- LONGITUD
	1368 SBUN	Deville THM 350 1981- 1987	0	0	SB17	 1110mm
CADILLAC - ESCALADE						
CONJUNTO SELECTOR CAMBIOS	3430 GMSCC	Escalade ESV, EXT, 2002-2006 T/Automática	5.3 L 6.0 L	88967320	SC59	 3531mm
	3382 GMSCC	Escalade 1999-2007 T/Automática	0	12477640	SC59	 3509mm
	3439 GMSCC	Escalade Traccion 2R 1999-2007 T/Automática	0	12477639	SC59	 3332mm
	3442 GMSCC	Escalade 2001-2006 T/Automática	0	19167308	SC59	 3241mm
	3477 GMSCC	Escalade Traccion 2R ESV 2009 T/Automática	0	19207880	SC59	 3370mm
	3476 GMSCC	Escalade Traccion 2R ESV Taccion 2R Hybrid 2007-2008 T/Automática	0	15945100	SC59	 3330mm
	3437 GMSCC	Escalade, ESV, EXT 2002-2006 T/Automática	5.3 L 6.0 L	88967321	SC59	 3332mm
	4306 GMSCC	Escalade 2007-2014 T/Automática	V8 Cil 6.8L	0	SC77	 3391mm
SELECTOR CAMBIOS	3465 GMSCC	Escalade 2007-2012 T/Automática	V8 Cil. 6.2 L	20787606	SC60 Tramo Inferior	 1620mm
	4192 GMSCC	Escalade 2018-2019 T/Automática	6.0L	23258955	SC60 Tramo Inferior	 1505mm
	2914 GMSCC	Escalade 1997-2000 T/Automática	V8 Cil. 5.7 L	15037353	SC46	 2874mm
	4029 GMSCC	Escalade 2015-2018 T/Automática	6.2 L	22791727	SC58 Tramo Superior	 1784mm

Enchro 1287 col. del Fresno Guadalajara Jal.











Tel. Multilínea (33) 3811 6917 - Servi-Cliente Cel. 33 1992 6768 - Guadalajara, Jalisco
Correo: ventas@flexcontrol.com.mx - www.flexcontrol.com.mx - www.cablesnavcar.com

Automóvil - Suv - Van - Pickup - Camiones Pesados - Ligeros

¡IMPORTANTE! Evite devoluciones o reclamos. Identifique previamente: marca, modelo y año del vehículo. En caso de duda, **CONSULTE** a su asesor.

NUESTRA MISIÓN... Ser su aliado en el desarrollo y crecimiento de su negocio

Competimos directamente con los ORIGINALES

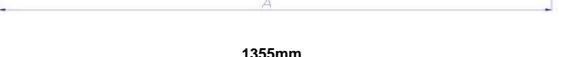
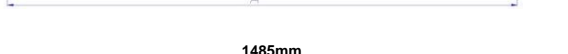







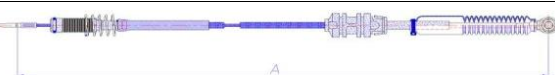

LINEA	CODIGO	MODELO	MOTOR	O.E.M	ARMADO	IMAGEN -- LONGITUD
SELECTOR CAMBIOS	3479 GMSCC	Escalade Traccion 2R Traccion 2R ESV Traccion 2R Hybrid 2009-2012	V8 Cil. 6.2 L	20787609	SC60 Tramo Inferior	 1395mm
	3466 GMSCC	Escalade Traccion 2R Hybrid 2007-2009 T/Automática	V8 Cil. 6.0 L	20787607	SC60 Tramo Inferior	 1397mm
	3467 GMSCC	Escalade Traccion 2R Hybrid 2007-2012 T/Automática	V8 Cil. 6.0 L	20787610	SC60 Tramo Inferior	 1446mm
	3480 GMSCC	Escalade Traccion 2R, Traccion 2R ESV, Traccion 2R Hybrid 2009-2011 T/Automática	V8 Cil. 6.0 L	20787611	SC60 Tramo Inferior	 1445mm
	3483 GMSCC	Escalade Traccion 4R 2007-2011 T/Automática	V8 Cil. 6.0 L	20787608	SC60 Tramo Inferior	 1505mm
	3484 GMSCC	Escalade Hybrid Platinum Ext Luxury 2011-2012 T/Automática	V8 Cil. 6.0 L 6.2 L	20787612	SC60 Tramo Inferior	 1485mm
	3715 GMSCC	Escalade Traccion 2R Traccion 4x4 2007 - 2012 T/Automática	0	19177020	SC77	 3280mm
	3716 GMSCC	Escalade Hybrid Traccion 2R Traccion 4R 2007 - 2012 T/Automática	0	19180564	SC77	 3370mm
	3440 GMSCC	Escalade Traccion 2R 1999-2007 T/Automática	V8 Cil. 6.0 L	25836132	SC57 Tramo Inferior	 1623mm
	3435 GMSCC	Escalade 1999-2007 T/Automática	V8 Cil. 6.0 L	15251896	SC58 Tramo Superior	 1892mm
	3438 GMSCC	Escalade Traccion 2R 1999-2007 T/Automática	V8 Cil. 6.0 L	15118283	SC57 Tramo Inferior	 1446mm
	3441 GMSCC	Escalade 2001-2006 T/Automática	V8 Cil. 6.0 L	15822857	SC57 Tramo Inferior	 1355mm
	3490 GMSCC	Escalade Traccion 2R ESV 2009 T/Automática	V8 Cil. 6.2 L	25982306	SC57 Tramo Inferior	 1485mm

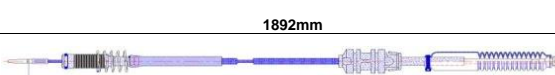
Automóvil - Suv - Van - Pickup - Camiones Pesados - Ligeros

¡IMPORTANTE! Evite devoluciones o reclamos. Identifique previamente: marca, modelo y año del vehículo. En caso de duda, **CONSULTE** a su asesor.

NUESTRA MISIÓN... Ser su aliado en el desarrollo y crecimiento de su negocio

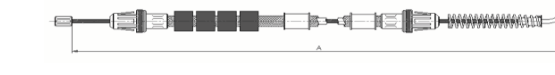
Competimos directamente con los ORIGINALES

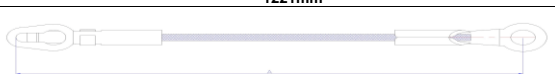
LINEA	CODIGO	MODELO	MOTOR	O.E.M	ARMADO	IMAGEN -- LONGITUD
SELECTOR CAMBIOS	3482 GMCS	Escalade Traccion 2R ESV 2009 T/Automática	V8 Cil. 6.2 L	15203850	SC58 Tramo Superior	 1892mm
	3481 GMCS	Escalade Traccion 2R ESV, Traccion 2R Hybrid 2007-2008 T/Automática	V8 Cil. 6.2 L	15909820	SC57 Tramo Inferior	 1445mm
	3482 GMCS	Escalade Traccion 2R ESV Traccion 2R Hybrid 2007-2008 T/Automática	V8 Cil. 6.2 L	15203850	SC58 Tramo Superior	 1892mm
	3436 GMCS	Escalade Traccion 2R 2000-2006 T/Automática	V8 Cil. 6.0 L	15784586	SC57 Tramo Inferior	 1446mm
	3435 GMCS	Escalade Traccion 2R 2000-2006 T/Automática	V8 Cil. 6.0 L	15251896	SC58 Tramo Superior	 1892mm
	3434 GMCS	Escalade Traccion 4x4 2000-2006 T/Automática	V8 Cil. 6.0 L	15784587	SC57 Tramo Inferior	 1645mm
	4011 GMCS	Escalade 2015... T/Automática	6.2 L	23258956	SC60 Tramo Inferior	 1505mm
	4010 GMCS	Escalade 2015... T/Automática	6.2 L	22893848	SC60 Tramo Inferior	 1393mm
FRENO DE MANO	2818 GMCFP	Escalade 2000 - 2004	V8 Cil. 6.0 L	15087072	FP263	 2558mm
ACELERADOR	3445 GMCAC	Escalade 1999-2000	V8 Cil. 5.7 L	15712337 22542664 15040848	AC247	 960mm
	3444 GMCAC	Escalade 1996-2000	0	15735412	AC116	 1221mm
SOPORTE COMPUERTA	3795 GMCSO	Escalade 1999 - 2007	V8 Cil. 6.1 L 5.7 L 5.1 L	16637944 16637945 88892972 88892973 88980510	CO6	 385mm
CADILLAC - FLEETWOOD						
SELECTOR CAMBIOS	2041 GMCS	Fleetwood 1985-1992 T/Automática	V8 Cil. 4.5 L	25524872	SC12	 1474mm

Encino 1287 col. del Fresno Guadalajara Jal.

Tel. Multilínea (33) 3811 6917 - Servi-Cliente Cel. 33 1992 6768 - Guadalajara, Jalisco
Correo: ventas@flexcontrol.com.mx - www.flexcontrol.com.mx - www.cablesnavcar.com

Automóvil - Suv - Van - Pickup - Camiones Pesados - Ligeros



IMPORTANTE. Evite devoluciones o reclamos. Identifique previamente: marca, modelo y año del vehículo. En caso de duda, **CONSULTE** a su asesor.

NUESTRA MISIÓN... Ser su aliado en el desarrollo y crecimiento de su negocio

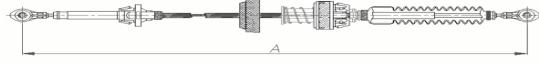
Competimos directamente con los ORIGINALES

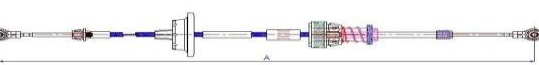

LINEA	CODIGO	MODELO	MOTOR	O.E.M	ARMADO	IMAGEN -- LONGITUD
SELECTOR CAMBIOS	3097 GMSCC	Fleetwood 1986-1993 T/Automática	V8 Cil. 4.5 L	25527523	SC29	 1352mm

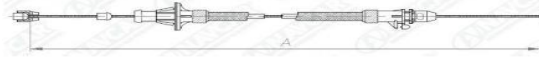
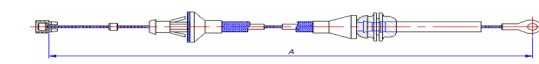
CADILLAC - SEVILLE

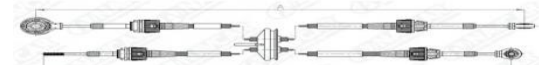
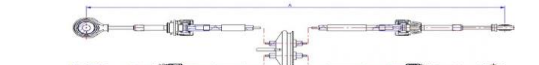

SELECTOR CAMBIOS	3643 GMSCC	Seville 2000 - 2005 T/Automática	V8 Cil. 4.5 L	15774350	SC68	 2072mm
	3417 GMSCC	Seville 2001-2008 T/Automática	V8 Cil. 4.5 L	25838820	SC62	 2176mm
FRENO DE MANO	3106 GMCFP	Seville SLS, STS 1993-1996	V8 Cil. 4.6 L 4.9 L	25639271 3527170	FP240 Principal	 2255mm
ACELERADOR	3931 GMCAC	Seville 1996-2002	V8 Cil. 4.6 L	3545150	AC155	 984mm
	1552 GMCA	Seville Todos 1980	V8 Cil. 5.7 L 4.1 L	14038644	AC3	 967mm

CHEVROLET

CHEVROLET - ASTRA

KIT SELECTOR Y NEUTRO CAMBIOS	3946 CHECC	Astra 2004-2006 T/Estándar	2.0 L	55351948	CC42	 A=1126mm/B=1207mm
KIT SELECTOR Y NEUTRO CAMBIOS	4358 CHECC	Astra 2001-2011 T/Estándar	1.8L 2.0L	24585932 93351858 93306003	CC140	 A=1113mm/B=1206mm
ACELERADOR	3322 GMCAC	Astra 1993-2002	L4 Cil. 2.0 L	90411037 847061	AC7	 835mm

CHEVROLET - ASTRO



SOBREMARCHA	2036 GMCSB	Astro 1992	V6 Cil. 4.3 L	10142019	SB2	 1067mm
	2040 GMCSB	Astro Traccion 2R Traccion 4R 1991-1992	0	10111682	SB2	 1028mm

Automóvil - Suv - Van - Pickup - Camiones Pesados - Ligeros





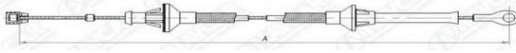

IMPORTANTE. Evite devoluciones o reclamos. Identifique previamente: marca, modelo y año del vehículo. En caso de duda, **CONSULTE** a su asesor.

NUESTRA MISIÓN... Ser su aliado en el desarrollo y crecimiento de su negocio

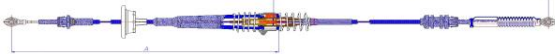
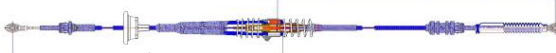
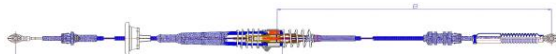
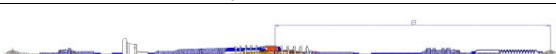
Competimos directamente con los ORIGINALES

LINEA	CODIGO	MODELO	MOTOR	O.E.M	ARMADO	IMAGEN -- LONGITUD
SELECTOR CAMBIOS	4365 GMSCC	Astro 1997-2002 T/Automática	0	15754075	SC168	 2908mm
ACELERADOR	1556 GMCA	Astro 1985 - 1986	V6 Cil. 4.3 L	15590109 15592356	AC1	 1023mm
ACELERADOR	3813 GMCAc	Astro 1998 - 2005	V6 Cil.	15153422	AC116	 1107mm

CHEVROLET - AVALANCHE

CONJUNTO SELECTOR CAMBIOS	3382 GMSCC	Avalanche 1999-2007 T/Automática	0	12477640	SC59	 3509mm
	3439 GMSCC	Avalanche Traccion 2R 1999-2007 T/Automática	0	12477639	SC59	 3332mm
	3442 GMSCC	Avalanche 2001-2006 T/Automática	0	19167308	SC59	 3241mm
	3476 GMSCC	Avalanche Traccion 2R 2007-2008 T/Automática	0	15945100	SC59	 3330mm
SELECTOR CAMBIOS	3434 GMSCC	Avalanche Traccion 4x4 1500, 2500, 2500 LS LT 2000-2006 T/Automática	V8 Cil. 5.3 L	15784587	SC57	 1645mm
	3466 GMSCC	Avalanche 2007-2009 T/Automática	V8 Cil. 5.3 L	20787607	SC60 Tramo Inferior	 1397mm
	3467 GMSCC	Avalanche Traccion 2R 2007-2012 T/Automática	V8 Cil. 5.3 L	20787610	SC60 Tramo Inferior	 1446mm
	3480 GMSCC	Avalanche Traccion 2R 2009-2011 T/Automática	V8 Cil. 5.3 L	20787611	SC60 Tramo Inferior	 1445mm
	3479 GMSCC	Avalanche Traccion 2R 2009-2012 T/Automática	V8 Cil. 5.3 L	20787609	SC60 Tramo Inferior	 1395mm
	3465 GMSCC	Avalanche Traccion 4x4 2007-2012 T/Automática	V8 Cil. 5.3 L	20787606	SC60 Tramo Inferior	 1620mm

Enchro 1287 col. del Fresno Guadalajara Jal.











Tel. Multilínea (33) 3811 6917 - Servi-Cliente Cel. 33 1992 6768 - Guadalajara, Jalisco
Correo: ventas@flexcontrol.com.mx - www.flexcontrol.com.mx - www.cablesnavcar.com

Automóvil - Suv - Van - Pickup - Camiones Pesados - Ligeros

¡IMPORTANTE! Evite devoluciones o reclamos. Identifique previamente: marca, modelo y año del vehículo. En caso de duda, **CONSULTE** a su asesor.

NUESTRA MISIÓN... Ser su aliado en el desarrollo y crecimiento de su negocio

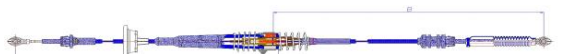
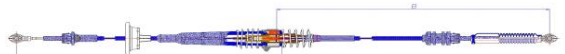
Competimos directamente con los ORIGINALES







LINEA	CODIGO	MODELO	MOTOR	O.E.M	ARMADO	IMAGEN -- LONGITUD
SELECTOR CAMBIOS	3483 GMSCC	Avalanche 1500 Traccion 4x4 2007-2011 T/Automática	V8 Cil. 5.3 L	20787608	SC60 Tramo Inferior	 1505mm
	3715 GMSCC	Avalanche Traccion 2R 2007 - 2012 T/Automática	V8 Cil. 5.3 L	19177020	SC77	 3280mm
	3440 GMSCC	Avalanche 1999-2007 T/Automática	V8 Cil. 5.3 L	25836132	SC57 Tramo Inferior	 1623mm
	3438 GMSCC	Avalanche Traccion 2R 1999-2007 T/Automática	V8 Cil. 5.3 L	15118283	SC57 Tramo Inferior	 1446mm
	3441 GMSCC	Avalanche 2001-2006 T/Automática	V8 Cil. 5.3 L	15822857	SC57 Tramo Inferior	 1355mm
	3481 GMSCC	Avalanche Traccion 2R 2007-2008 T/Automática	V8 Cil. 5.3 L	15909820	SC57 Tramo Inferior	 1445mm
	3482 GMSCC	Avalanche Traccion 2R 2007-2008 T/Automática	V8 Cil. 5.3 L	15203850	SC58 Tramo Superior	 1892mm
	3436 GMSCC	Avalanche 1500, 2500, 3500 Traccion 2R LS LT 2000-2006 T/Automática	V8 Cil. 5.3 L	15784586	SC57 Tramo Inferior	 1446mm
	3435 GMSCC	Avalanche 1500, 2500, 3500 Traccion 2R LS LT 2000-2006 T/Automática	V8 Cil. 5.3 L	15251896	SC58 Tramo Superior	 1892mm
	3437 GMSCC	Avalanche 1500, 2500, 3500 LS LT / 2002-2006 T/Automática	V8 Cil. 5.3 L	88967321	SC59	 3332mm
	3430 GMSCC	Avalanche T/Automática	5.3 L	88967320	SC59	 3531mm
FRENO DE MANO	2818 GMCFP	Avalanche 1500 2000 - 2004	V8 Cil. 5.3 L	15087072	FP263	 2558mm
ACELERADOR	3445 GMCAC	Avalanche 1999-2000	V8 Cil. 5.3 L	15712337 22542664 15040848	AC247	 960mm

Automóvil - Suv - Van - Pickup - Camiones Pesados - Ligeros

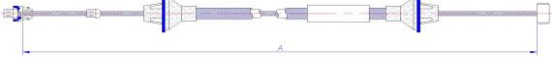
IMPORTANTE. Evite devoluciones o reclamos. Identifique previamente: marca, modelo y año del vehículo. En caso de duda, **CONSULTE** a su asesor.

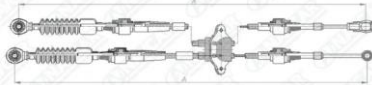
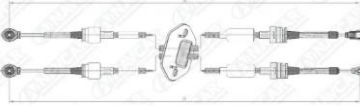
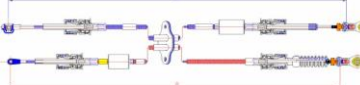
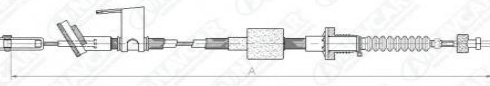
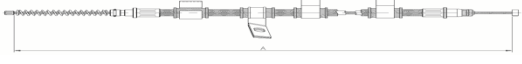
NUESTRA MISIÓN... Ser su aliado en el desarrollo y crecimiento de su negocio

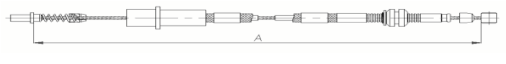
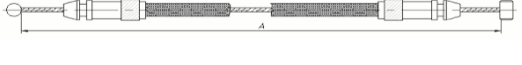
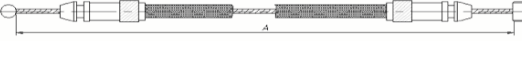
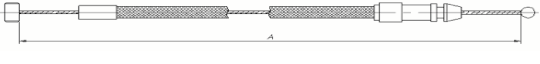
Competimos directamente con los ORIGINALES

LINEA	CODIGO	MODELO	MOTOR	O.E.M	ARMADO	IMAGEN -- LONGITUD
ACELERADOR	3928 GMCAC	Avalanche 2001-2002	V8 Cil. 5.3 L	15040848	AC247	 956mm
SOPORTE COMPUERTA	3795 GMCSC	Avalanche 1999 - 2007	V8 Cil. 5.3 L	16637944 16637945 88892972 88892973 88980510	CO6	 385mm
CHEVROLET - AVEO						
KIT SELECTOR Y NEUTRO CAMBIOS	3741 GMCCC	Aveo 2004-2008 T/Estándar	0	96331519	CC19	 A=1192mm/B=1160mm
KIT SELECTOR Y NEUTRO CAMBIOS	3841 GMCCC	Aveo 2012... T/Estándar	0	24105496	CC40	 A=1109mm/B=1137mm
KIT SELECTOR Y NEUTRO CAMBIOS	4392 CHECC	Aveo 2015 - 2020 T/Estándar	0	24112063	CC145	 A=1200mm/B=1230mm
EMBRAGUE	3579 GMCEM	Aveo 2012...	0	24105069	EM134 Cable plastificado	 952 mm
FRENO DE MANO	2565 GMCFP	Aveo 2006...	1.6 L	96534870	FP199 Trasero Izquierdo	 1383mm
	2564 GMCFP	Aveo 2006...	1.6 L	96534871	FP199 Trasero Derecho	 1403mm
ACELERADOR	2438 GMCAC	Aveo sedan, GTI 2004-2012	L4 Cil. 1.6 L	96452590	AC13	 690mm
APERTURA CAJUELA	2926 GMCAB	Aveo Hatchback 2004...	L4 Cil. 1.6 L	96540942	AB2	 2410mm
	3431 GMCAB	Aveo sedan 2004-2006	L4 Cil. 1.6 L	96541118	AB2	 3533mm
APERTURA COFRE	3500 GMCCA	Aveo sedan 2004 - 2011	L4 Cil. 1.6 L	96649313	CP4	 1760mm
APERTURA COFRE	3854 GMCCA	Aveo 2013 - 2015	0	9061797	CP4	 1715mm









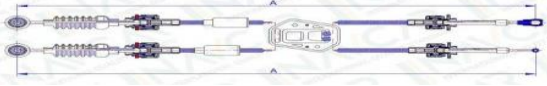

Encino 1287 col. del Fresno Guadalajara Jal.

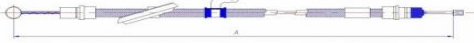
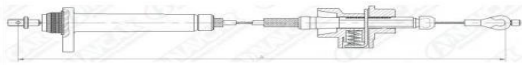
Automóvil - Suv - Van - Pickup - Camiones Pesados - Ligeros

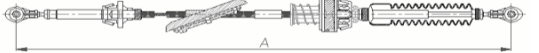
IMPORTANTE. Evite devoluciones o reclamos. Identifique previamente: marca, modelo y año del vehículo. En caso de duda, **CONSULTE** a su asesor.

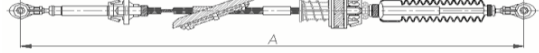
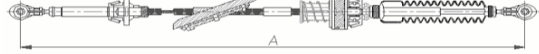
NUESTRA MISIÓN... Ser su aliado en el desarrollo y crecimiento de su negocio

Competimos directamente con los ORIGINALES







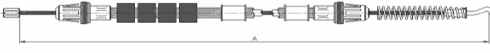

LINEA	CODIGO	MODELO	MOTOR	O.E.M	ARMADO	IMAGEN -- LONGITUD
CHEVROLET - BEAT						
KIT SELECTOR Y NEUTRO CAMBIOS	3982 CHECC	Beat 2013... T/Standar	L4 Cil. 1.2L	25189436 25198661 25196857	CC57	 A=1155mm/B=1053mm
ACELERADOR	3517 GMCAC	Beat 2010...	0	0	AC13	 1448mm
FRENO DE MANO	4274 CHEFP	Beat 2018	1.2L	95421243	FP501 Trasero Izquierdo	 1390mm
CHEVROLET - BERETTA						
SOBREMARCHA	2035 GMCSCB	Beretta 1990-1995	V6 Cil. 4.1 L	10153882	SB2	 1410mm
CHEVROLET - BLAZER						
SELECTOR CAMBIOS	2151 GMCSC	Blazer Traccion en 2R 1995 - 1997 T/Automática	V6 Cil. 4.3 L	15721262	SC27	 2144mm
	3402 GMCSC	Blazer Traccion 4x4 1995-1998 T/Automática	V6 Cil. 4.3 L	15721261	SC27	 2576mm
	4007 GMCSC	Blazer 1998-2005 T/Automática	V6 Cil. 4.3 L	15189198	SC27	 2523mm
	2159 GMCSC	Blazer Traccion 4x4 1996 - 2003 T/Automática	V6 Cil. 4.3 L	15021558 15713353	SC27	 2800mm
	2162 GMCSC	Blazer Traccion 2R 1998 - 2002 T/Automática	V6 Cil. 4.3 L	15021556	SC27	 2376mm
	3807 GMCSC	Blazer 1998-2005 T/Automática	4 Cil. 2.2 L	15189203	SC27	 2861mm
	3866 GMCSC	Blazer 1998-2005 T/Automática	V6 Cil. 4.3 L L4 Cil. 2.2 L	15189199	SC27	 2042mm
EMBRAGUE	2277 GMCCEM	Blazer 1982-1983	V6 Cil. 4.3 L	14030848	EM94 Con Tope	 440mm

Automóvil - Suv - Van - Pickup - Camiones Pesados - Ligeros

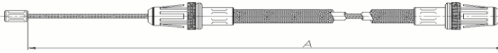
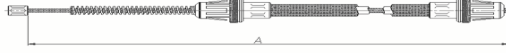
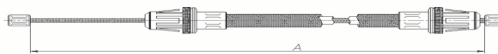
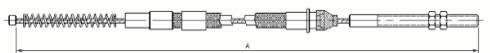
IMPORTANTE. Evite devoluciones o reclamos. Identifique previamente: marca, modelo y año del vehículo. En caso de duda, **CONSULTE** a su asesor.

NUESTRA MISIÓN... Ser su aliado en el desarrollo y crecimiento de su negocio

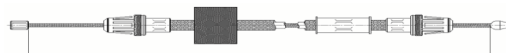
Competimos directamente con los ORIGINALES











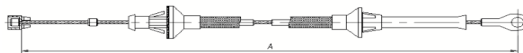

LINEA	CODIGO	MODELO	MOTOR	O.E.M	ARMADO	IMAGEN -- LONGITUD
	2276 GMCEM	Blazer 1982-1983	V6 Cil. 4.3 L	14062618	EM93 Con Tornillo	 188mm
FRENO DE MANO	2818 GMCFCP	Blazer 2000 - 2004	V8 Cil. 5.3 L	15087072	FP263	 2558mm
	286 CHBF	Blazer 1996...	V6 Cil. 4.3 L	15025402	FP457 Principal	 1090mm
	2621 GMCFCP	Blazer 1998 - 2001	V6 Cil. 4.3 L	15724598	FP240 Principal	 923mm
	2769 GMCFCP	Blazer 1992 - 1994	V6 Cil. 4.3 L	15640541	FP239 Trasero Izquierdo	 1952mm
	240 CHBF	Blazer 1996...	V6 Cil. 4.3 L	15741309	FP240 Trasero Izquierdo	 1880mm
	1640 GMCF	Blazer 1997...	V6 Cil. 4.3 L	93259373	FP149 Trasero Izquierdo	 1435mm
	3146 GMCFCP	Blazer 1999	V6 Cil. 4.3 L	15724596 15052598 18052598	FP270 Trasero Izquierdo	 1812mm
	239 CHBF	Blazer 1996...	V6 Cil. 4.3 L	15709830	FP464 Trasero Derecho	 2708mm
FRENO DE MANO	1639 GMCF	Blazer 1997...	V6 Cil. 4.3 L	93248612	FP155 Trasero Derecho	 2820mm
	3145 GMCFCP	Blazer 1999	V6 Cil. 4.3 L	15769538	FP229 Trasero Derecho	 2650mm
	3108 GMCFCP	Blazer Traccion 4x4 1996-1997	V6 Cil. 4.3 L	15709831 15741310	FP272 Trasero Izquierdo	 1758mm
LIBERADOR FRENO	1635 GMCF	Blazer 1995	V6 Cil. 4.3 L	93228406	LF1	 377mm

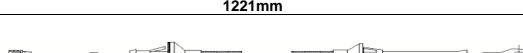
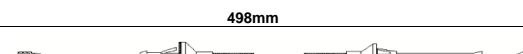
Automóvil - Suv - Van - Pickup - Camiones Pesados - Ligeros

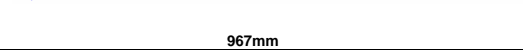
IMPORTANTE. Evite devoluciones o reclamos. Identifique previamente: marca, modelo y año del vehículo. En caso de duda, **CONSULTE** a su asesor.

NUESTRA MISIÓN... Ser su aliado en el desarrollo y crecimiento de su negocio

Competimos directamente con los ORIGINALES







LINEA	CODIGO	MODELO	MOTOR	O.E.M	ARMADO	IMAGEN -- LONGITUD
ACELERADOR	1556 GMCA	Blazer 1982-1986	4L Cil. 1.9 L	15590109 15592356	AC1	 1023mm
	1830 GMCAC	Blazer 1975 - 1978	V6 Cil. 4.1 L	1248073	AC1	 493mm
	3443 GMCAC	Blazer Traccion 2R Traccion 4x4 1996 - 1997	V6 Cil. 4.1 L	15733071	AC116	 1051mm
	3444 GMCAC	Blazer 1996-2000	0	15735412	AC116	 1221mm
	1549 GMCA	Blazer 1977 - 1979	V6 Cil. 4.1 L	1248083	AC1	 498mm
	1551 GMCA	Blazer 1982 - 1985	V6 Cil. 2.8 L	14036110	AC1	 760mm
ACELERADOR	1552 GMCA	Blazer 1982 - 1989	V6 Cil. 2.8 L	14038644	AC3	 967mm
	1556 GMCA	Blazer Pickup 1985 - 1986	V6 Cil. 4.3 L	15590109 15592356	AC1	 1023mm
	1559 GMCA	Blazer 1992 - 1994	V8 Cil. 5.7 L	15552822	AC1	 780mm
	1524 GMCA	Blazer Motor 262Z 1988 - 1990	V6 Cil. 4.3 L	15622442	AC1	 796mm
	1519 GMCA	Blazer Motor 305F 1983 - 1986	V6 Cil. 4.3 L	25515839	AC1	 630mm
	2042 GMCAC	Blazer S500 1992-1997	V6 Cil. 4.3 L	15959410 15693481	AC116	 886mm
	2036 GMCSB	Blazer 1992	V.6 Cil. 4.3 L	10142019	SB2	 1067mm

Automóvil - Suv - Van - Pickup - Camiones Pesados - Ligeros

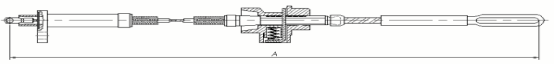

IMPORTANTE. Evite devoluciones o reclamos. Identifique previamente: marca, modelo y año del vehículo. En caso de duda, **CONSULTE** a su asesor.

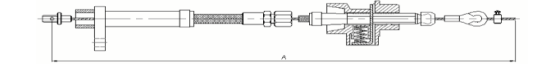
NUESTRA MISIÓN... Ser su aliado en el desarrollo y crecimiento de su negocio

Competimos directamente con los ORIGINALES

LINEA	CODIGO	MODELO	MOTOR	O.E.M	ARMADO	IMAGEN -- LONGITUD
SOBREMARCHA	2040 GMC SB	Blazer Traccion 2R Traccion 4x4 1991	0	10111682	SB2	 1028mm
	559 CHSB	Blazer WTHM350 292,250 1977-1978	V.6 Cil. 4.3 L	1262618	SB3	 1114mm
	1622 GMSB	Blazer 1983 - 1984	0	25515600	SB2	 1185mm
	1513 CHSB	Blazer 1992	0	10174462	SB21	 1030mm
	840 CHSB	Blazer Traccion 4x4 TH700 1985-1986	0	25515598	SB2	 1060mm
	1367 SBUN	Blazer TH700 1982 - 1990	0	0	SB18	 1255mm
SOPORTE CAJUELA	516 CHEC	Blazer todos	V6 Cil. 4.3 L	15683449 15683450	CO1	 370mm
SOPORTE COMPUERTA	3639 GMCSO	Blazer 1973 - 1982	V6 Cil. 4.3 L	6274850	CO4	 556mm

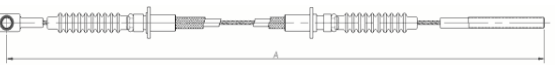
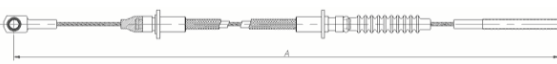
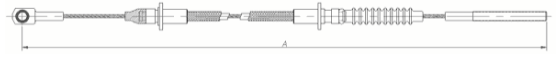
CHEVROLET - BRIGADIER

EMBRAGUE	262 CHBE	Brigadier	0	15557241	EM125	 1875mm
	455 CHBE	Super Brigadier ... 1989	0	15557241	EM1	 1990mm
	312 CHBE	Brigadier	0	15557241	EM125	 1875mm
ACELERADOR (Bernier)	1151 CHBA	Brigadier 1980...	0	2060507	AC131	 2590mm







CHEVROLET - C10 - C20 - C30

Automóvil - Suv - Van - Pickup - Camiones Pesados - Ligeros

IMPORTANTE. Evite devoluciones o reclamos. Identifique previamente: marca, modelo y año del vehículo. En caso de duda, **CONSULTE** a su asesor.

NUESTRA MISIÓN... Ser su aliado en el desarrollo y crecimiento de su negocio

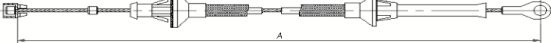
Competimos directamente con los ORIGINALES

LINEA	CODIGO	MODELO	MOTOR	O.E.M	ARMADO	IMAGEN -- LONGITUD
FRENO DE MANO	489 CHLF	C10	V8 Cil. 5.7 L V6 Cil. 4.3 L	95602358	FP3 Central	 2729mm
SOBREMARCHA	840 CHSB	C10 / C20 / C30 TH700 1985-1986	0	25515598	SB2	 1060mm
ACELERADOR	1830 GMCAC	C10 / C30 MAQ. 350 1975 - 1978	V6 Cil. 4.1 L	1248073	AC1	 493mm
	1519 GMCA	C10 / C20 / C30 1984 - 1993	V6 Cil. 4.3 L	25515839	AC1	 630mm
	1552 GMCA	C10 / C20 / C30 Todos 1982-1986	V6 Cil. 2.8 L	14038644	AC3	 967mm
	1549 GMCA	C10 / C30 MAQ.292 1979...	V6 Cil. 4.1 L	1248083	AC1	 498mm
APERTURA COFRE	1052 CHEC	C10 / C20 / C30 1984...	V8 Cil. 5.7 L V6 Cil. 4.3 L	14039963	CP1	 1977mm
SOPORTE COMPUERTA	3639 GMCSO	C10 1973 - 1982	V6 Cil. 4.3 L	6274850	CO4	 556mm

CHEVROLET - C100 - C200 - C300

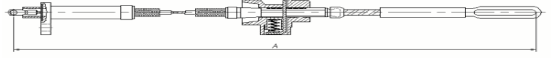
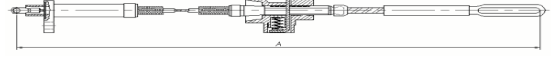
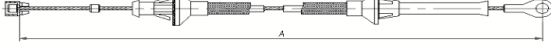
SOBREMARCHA	1622 GMSB	C100 / C200 1983 - 1984	0	25515600	SB2	 1185mm
	551 GMSB	C300 THM350 1979 - 1980	0	1262620	SB3	 1084mm
	559 CHSB	C100 / C300 THM350 292 1978	0	1262618	SB3	 1114mm
ACELERADOR	1549 GMCA	C100 / C200 Series Trucks 1977 - 1979	V6 Cil. 4.1 L	1248083	AC1	 498mm



CHEVROLET - C1500 - C2500 - C3500

Automóvil - Suv - Van - Pickup - Camiones Pesados - Ligeros

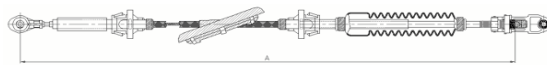

IMPORTANTE. Evite devoluciones o reclamos. Identifique previamente: marca, modelo y año del vehículo. En caso de duda, **CONSULTE** a su asesor.

NUESTRA MISIÓN... Ser su aliado en el desarrollo y crecimiento de su negocio



Competimos directamente con los ORIGINALES

LINEA	CODIGO	MODELO	MOTOR	O.E.M	ARMADO	IMAGEN -- LONGITUD
SELECTOR CAMBIOS	2914 GMCSC	C1500 Traccion 2R 1995-2002 T/Automática	V6 Cil. 4.3 L	15037353	SC46	 2874mm
ACELERADOR	3444 GMCAC	C1500 / C2600 1996-2000	0	15735412	AC116	 1221mm
	1563 GMCA	C1500 / C2500 / C3500 1988-1990	V8 Cil. 6.2 L	15552819	AC3	 1248mm

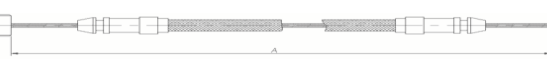
CHEVROLET - CAPTIVA

FRENO DE MANO	3832 GMCFCP	Captiva / Captiva Sport 2008-2015	V6 Cil. 3.0 L L4 Cil. 2.4 L	22857406	FP384 Trasero Derecho	 1123mm
	3833 GMCFCP	Captiva Captiva Sport 2008-2015	V6 Cil. 3.0 L L4 Cil. 2.4 L	22857407	FP384 Trasero Izquierdo	 1153mm
APERTURA COFRE	3834 GMCCA	Captiva / Captiva Sport 2008-2015	V6 Cil. 3.0 L L4 Cil. 2.4 L	20840749	CP9	 2075mm

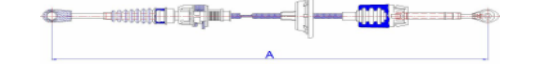
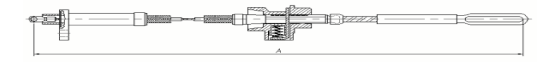
CHEVROLET - CAMARO

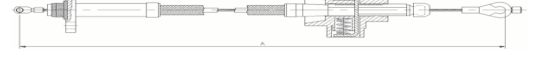

SELECTOR CAMBIOS	1763 GMCSC	Camaro 1983 - 1986 T/Automático	0	10232154 10027632	SC11	 730mm
SELECTOR CAMBIOS	4248 CHESC	Camaro 1993-2002	3.4 L 3.8 L	12558306	SC143	 720mm
SOBREMARCHA	559 CH5B	Camaro THM350 1978-1979	0	1262618	SB3	 1114mm
	840 CH5B	Camaro TH700 1983-1987	0	25515598	SB2	 1060mm
	2292 GMCSB	Camaro THM200 1982-1983	L4 Cil. 2.5 L.	1644356	SB2	 575mm
	1508 GMSB	Camaro THM350 1981	V8 Cil. 3.8 L	25507541	SB19	 928mm

Automóvil - Suv - Van - Pickup - Camiones Pesados - Ligeros



IMPORTANTE. Evite devoluciones o reclamos. Identifique previamente: marca, modelo y año del vehículo. En caso de duda, **CONSULTE** a su asesor.

NUESTRA MISIÓN... Ser su aliado en el desarrollo y crecimiento de su negocio

Competimos directamente con los ORIGINALES

LINEA	CODIGO	MODELO	MOTOR	O.E.M	ARMADO	IMAGEN -- LONGITUD
SOBREMARCHA	1621 GMSB	Camaro THM700 1983	0	25517311	SB2	 1335mm
	2297 GMCSB	Camaro R4 1988-1989	V8 Cil. 5.0 L	10066475	SB2	 1050mm

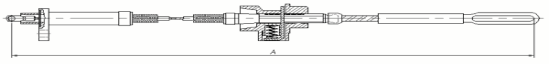
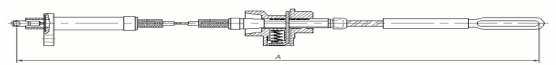
CHEVROLET - CAPRICE

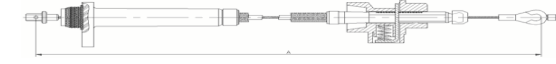
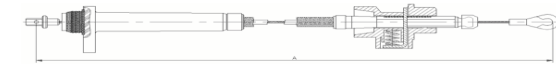
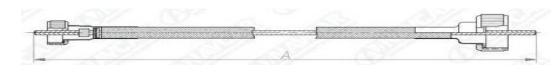
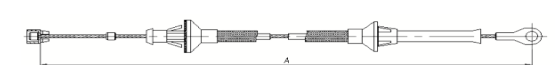
LIBERADOR FRENO	951 ECAAF	Caprice	V8 Cil. 5.7 L	0	LF1	 246mm
SOBREMARCHA	559 CHSB	Caprice THM350 1978-1979	0	1262618	SB3	 1114mm
	553 CHSB	Caprice TH350	0	342486	SB3	 1005mm
	840 CHSB	Caprice TH700 1982-1988	0	25515598	SB2	 1060mm
	2297 GMCSB	Caprice THM200 1988-1989	V8 Cil. 5.0 L	10066475	SB2	 1050mm
	2291 GMCSB	Caprice THM200 1985-1987	V6 Cil. 4.3 L	25521267	SB2	 786mm
VELOCIMETRO	2169 GMCVU	Caprice 1967	V6 Cil. 3.6 L	25032876	VZ80	 966mm
ACELERADOR	353 ECAAF	Caprice 1975-1980	V8 Cil. 5.7 L	1252955	AC1	 521mm

CHEVROLET - CAVALIER

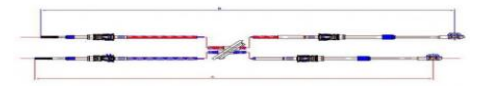
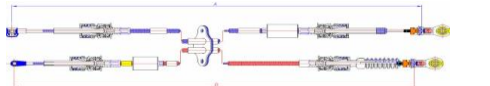









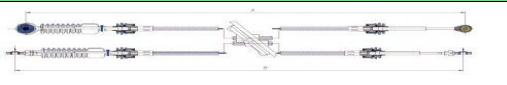
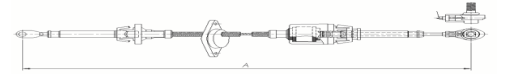
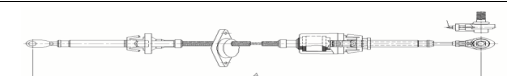

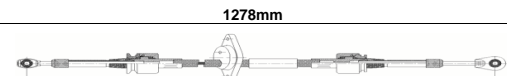
KIT SELECTOR Y NEUTRO CAMBIOS	4149 CHECC	Cavalier 2000-2005 T/Standar	2.2L	22707146	CC104	 A=1487mm/B=1445mm
KIT SELECTOR Y NEUTRO CAMBIOS	4392 CHECC	Cavalier 2005 - 2015 T/Standar	1.5L	24112063	CC145	 A=1200mm/B=1230mm

Automóvil - Suv - Van - Pickup - Camiones Pesados - Ligeros

¡IMPORTANTE! Evite devoluciones o reclamos. Identifique previamente: marca, modelo y año del vehículo. En caso de duda, **CONSULTE** a su asesor.

NUESTRA MISIÓN... Ser su aliado en el desarrollo y crecimiento de su negocio

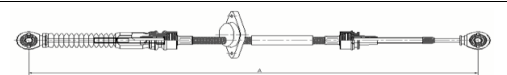
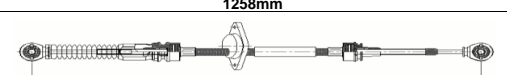
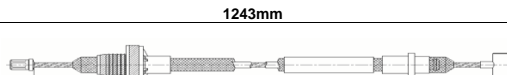
Competimos directamente con los ORIGINALES

LINEA	CODIGO	MODELO	MOTOR	O.E.M	ARMADO	IMAGEN -- LONGITUD
KIT SELECTOR Y NEUTRO CAMBIOS	3677 GMCCC	Cavalier 1996-1999	2.0 L 2.4 L	22650715	CC88	 A=1478mm/B=1467mm
		T/Standar				
SELECTOR CAMBIOS	1768 GMCS	Cavalier 1991-1994	L4 Cil. 2.2 L	10022405	SC15	 1265mm
	1767 GMCS	Cavalier THM125 1987 - 1988	L4 Cil. 2.0 L	10034333	SC15	 1278mm
	3423 GMCS	Cavalier 1986-1987	L4 Cil. 2.0 L	22535553 22535554 22535555 10066450 14093374	SC68	 1278mm
	3058 GMCS	Cavalier Z24, RS	L4 Cil. 2.8 L V6 Cil. 3.1 L	10079796 22539956	SC50	 1280mm
	3561 GMCS	Cavalier 1992 - 2002	L4 Cil. 2.2 L	22621784	SC70	 1344mm
	3815 GMCS	Cavalier Base Z24 Convertible 1995 - 2005	V6 Cil. 3.1 L	22737100 22718296	SC70	 1297mm
SELECTOR CAMBIOS	3696 GMCS	Cavalier RS, VL, Z24 1992-1994	V6 Cil. 3.1 L	22575726	SC69	 1177mm
	3700 GMCS	Cavalier RS, VL, Z24 1992-1994	V6 Cil. 3.1 L	22578976 22571779	SC69	 1242mm
	3985 CHESC	Cavalier 1996-1999	2.0 L 2.3 L 2.4 L	22650715	SC91	 1517mm
SELECTOR CAMBIOS	3057 GMCS	Cavalier 1988-1991	V6 Cil. 3.1 L	100779847 22539962	SC49	 1262mm
	3386 GMCS	Cavalier Nacional 1992-1994	V6 Cil. 3.1 L	22578975	CC31	 1258mm
SELECTOR CAMBIOS	2817 GMCCC	Cavalier RS, VL, Z24 1991 - 1994	L4 Cil. 2.2 L	22571778 22590451	CC31	 1243mm
EMBRAGUE	2278 GMCEM	Cavalier 1983-1984	L4 Cil. 2.0 L	14068795	EM95	 920mm
FRENO DE MANO	2852 GMCFP	Cavalier 2000-2001	L4 Cil. 2.2 L	18037832	FP239 Trasero	 649mm
FRENO DE MANO	2871 GMCFP	Cavalier 1997-2002	L4 Cil. 2.2 L	22651234	FP220 Trasero Derecho/Izquierdo	 634mm

Encino 1287 col. del Fresno Guadalajara Jal.

Tel. Multilínea (33) 3811 6917 - Serv. Cliente Cal. 33 1992 6768 - Guadalajara, Jalisco

Correo: ventas@flexcontrol.com.mx - www.flexcontrol.com.mx - www.cablesnavcar.com

Automóvil - Suv - Van - Pickup - Camiones Pesados - Ligeros



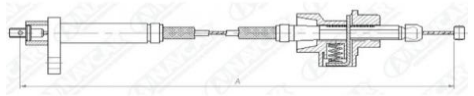
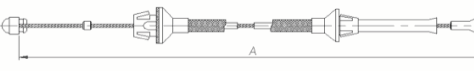
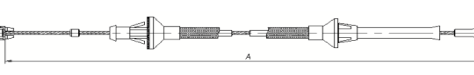
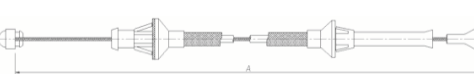

IMPORTANTE. Evite devoluciones o reclamos. Identifique previamente: marca, modelo y año del vehículo. En caso de duda, **CONSULTE** a su asesor.

NUESTRA MISIÓN... Ser su aliado en el desarrollo y crecimiento de su negocio

Competimos directamente con los ORIGINALES

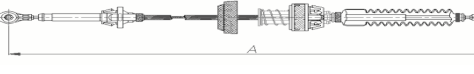
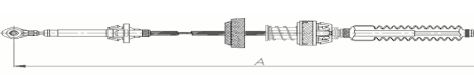
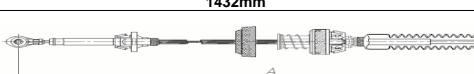
LINEA	CODIGO	MODELO	MOTOR	O.E.M	ARMADO	IMAGEN -- LONGITUD
SOBREMARCHA	1514 CHSB	Cavalier 1995	0	10142068	SB21	 825mm
ACELERADOR	2198 GMCAC	Cavalier 1988-1994	V6 Cil. 3.1 L	10079816	AC172	 820mm
	1818 GMCAC	Cavalier 1990-1996	V6 Cil. 3.1 L	10079816	AC1	 820mm
	2206 GMCAC	Cavalier Z-24 1988	L4 Cil. 2.0 L	0	AC231	 822mm

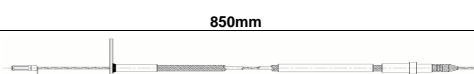
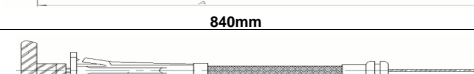
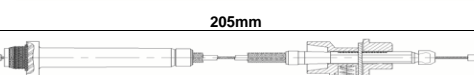
CHEVROLET - CELEBRITY

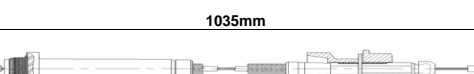
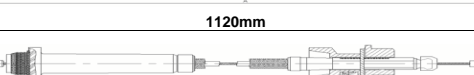
SELECTOR CAMBIOS	3423 GMCSC	Celebrity 1986-1987 T/Standard	L4 Cil. 2.0 L	2253553 2253554 2253555 10066450 14093374	SC68	 1278mm
	3416 GMCSC	Celebrity 1986-1996 T/Automática	V6 Cil. 3.8 L	12552510	SC29	 1504mm
	2521 GMCSC	Celebrity THM125 1986 - 1990 T/Automática	L4 Cil. 2.5 L	10038609	SC29 Palanaca al volante	 1432mm
	2529 GMCSC	Celebrity THM440 THM125 1986 - 1992 T/Automática	L4 Cil. 2.5 L V6 Cil. 2.8 L 3.1 L	10038603	SC29	 1508mm
EMBRAGUE	2273 GMCEM	Celebrity 1985-1988	L4 Cil. 2.5 L V6 Cil. 2.8 L	14056659	EM92	 850mm
	2272 GMCEM	Celebrity 1985-1988	L4 Cil. 2.5 L V6 Cil. 2.8 L	14056660	EM92	 840mm
LIBERADOR FRENO	934 ECEP	Celebrity 1982...	L4 Cil. 2.5 L	14049336	LF1	 205mm
SOBREMARCHA	557 CHSB	Celebrity TH125	0	1262487	SB2	 1221mm
	1659 GMSB	Celebrity THM125C 1982 - 1983	0	25513393	SB2	 1035mm
	1617 GMSB	Celebrity THM125C 1984 - 1986	0	25519347	SB2	 1120mm
SOBREMARCHA	2289 GMCSCB	Celebrity 1982-1985	V6 Cil. 4.3 L	25510971	SB2	 776mm







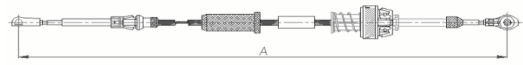
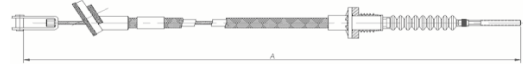
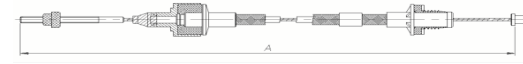
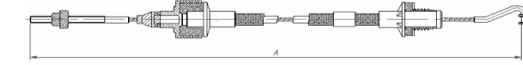
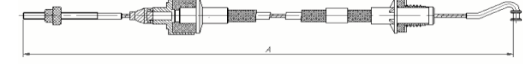
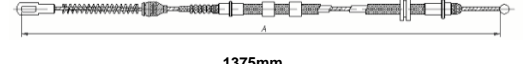

Encino 1287 col. del Fresno Guadalajara Jal.

Automóvil - Suv - Van - Pickup - Camiones Pesados - Ligeros

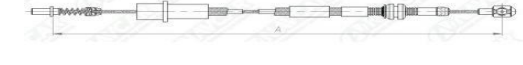
¡IMPORTANTE! Evite devoluciones o reclamos. Identifique previamente: marca, modelo y año del vehículo. En caso de duda, **CONSULTE** a su asesor.

NUESTRA MISIÓN... Ser su aliado en el desarrollo y crecimiento de su negocio

Competimos directamente con los ORIGINALES

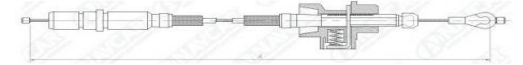
LINEA	CODIGO	MODELO	MOTOR	O.E.M	ARMADO	IMAGEN -- LONGITUD
CHEVROLET - CHEVY						
SELECTOR CAMBIOS	2157 GMSCC	Chevy C2 todos 2002 - 2003 T/Automática	L4 Cil. 1.8 L	90523047 Z3508FHP	SC37	 1254mm
EMBRAGUE	349 SWIE	Chevy Taxi 1989-1993	L4 Cil. 1.4 L	2371063B10 30015828	EM12	 591mm
	1956 GMCEM	Chevy Monza 1996...	L4 Cil. 1.2 L 1.4 L 1.6 L 1.7 L	90522447	EM85	 804mm
	1937 GMCEM	Chevy Pop todos 1994...	L4 Cil. 1.2 L 1.4 L 1.6 L 1.7 L	90446929 93247035	EM4	 781mm
	2120 GMCEM	Chevy Pop todos 1994 - 1996 Diesel 2003...	L4 Cil. 1.3 L 1.7 L (diesel)	90446929	EM4	 741mm
FRENO DE MANO	206 CORF	Chevy todos	L4 Cil. 1.6 L	90445985	FP15 Trasero Izquierdo	 1375mm
	207 CORF	Chevy todos	L4 Cil. 1.6 L	90445986 0522614 0522642	FP14 Trasero Derecho	 1090mm
ACELERADOR	3322 GMCAC	Chevy Joy, Pop 1996-2011	L4 Cil. 2.0 L	90411037 847061	AC7	 835mm
	281 CHMA	Chevy Corsa 1993-1996	L4 Cil. 1.2 L	94626707	AC7	 769mm
	137 CORA	Chevy Corsa 1993-1996	L4 Cil. 1.2 L	90411033	AC7	 761mm
	810 SWIA	Chevy Taxi 1991... / 1996...	L4 Cil. 1.4 L	1591063B21	AC19	 805mm
APERTURA COFRE	142 CORC	Chevy Pop 1994...	L4 Cil. 1.6 L	90482081	CP2	 1470mm
	3824 GMCCA	Chevy 1993 - 2008	L4 Cil. 1.6 L	15721262	CP2	 1477mm
VELOCIMETRO	677 GMCVZ	Chevy 1996-2011	L4 Cil. 1.6 L	93231079 94423497	VZ53	 860mm
CHEVROLET - CHEVETTE						
SORREMARCHA	856 CHSB	Chevette Caja Carburador 1985 - 1987	V8 Cil. 6.2 L	94648860	SB1	 1118mm

Encino 1287 col. del Fresno Guadalajara Jal.







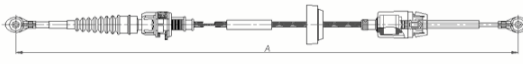
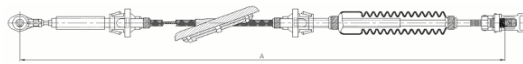
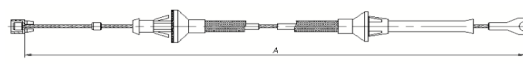
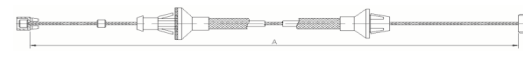

Tel. Multilínea (33) 3811 6917 - Servi-Cliente Cel. 33 1992 6768 - Guadalajara, Jalisco
Correo: ventas@flexcontrol.com.mx - www.flexcontrol.com.mx - www.cablesnavcar.com

Automóvil - Suv - Van - Pickup - Camiones Pesados - Ligeros

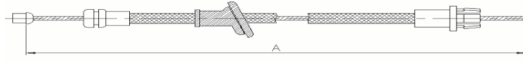
IMPORTANTE. Evite devoluciones o reclamos. Identifique previamente: marca, modelo y año del vehículo. En caso de duda, **CONSULTE** a su asesor.

NUESTRA MISIÓN... Ser su aliado en el desarrollo y crecimiento de su negocio

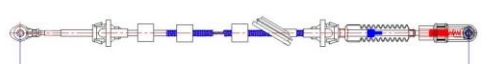
Competimos directamente con los ORIGINALES

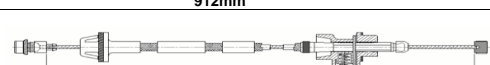



LINEA	CODIGO	MODELO	MOTOR	O.E.M	ARMADO	IMAGEN -- LONGITUD
SOBREMARCHA	558 CHSB	Chevette Caja Carburador 1988	V8 Cil. 6.2 L	52281204	SB1	 1209mm
CHEVROLET - CHEYENNE						
SELECTOR CAMBIOS	2163 GMCSC	Cheyenne 1999-2002 T/Automática	V8 Cil. 6.2 L	15095767 15037363	SC30	 2667mm
	2914 GMCSC	Cheyenne 1997-1999 T/Automática	V6 Cil. 4.3 L	15037353	SC46	 2874mm
ACELERADOR	1129 CHEA	Cheyenne 1500 / 3500 ... 1996	V8 Cil. 6.2 L	0	AC1	 894mm
	1130 CHEA	Cheyenne 1500, 3500 1996...	V8 Cil. 6.2 L	15733560	AC116	 1215mm
	3380 GMCAC	Cheyenne 1500 ...1999	0	0	AC1	 775mm
APERTURA COFRE	3379 GMCAC	Cheyenne 1500 ...1996	V8 Cil. 6.2 L	15698066	CP23	 2145mm
SOBREMARCHA	840 CHSB	Cheyenne	0	25515598	SB2	 1060mm
SOPORTE CAJUELA	1702 CHEC	Cheyenne 1500 / 3500 1991 - 1998	V8 Cil. 6.2 L	15673251	CO1	 360mm
CHEVROLET - CITATION						
SELECTOR CAMBIOS (Selector)	3776 GMCSC	Citation 1981 T/Automático	0	10017823	SC76	 1273mm
SOBREMARCHA	1658 GMSB	Citation THM125C 1980 - 1981	0	25513389	SB2	 607mm
CHEVROLET - COLORADO						
SELECTOR CAMBIOS	4319 CHESC	Colorado 2009-2012 Automática	2.9L 3.7L	25800703	SC157	 1672mm
	2637 GMCAC	Colorado (Luv D-Max) Gasolina 2005...	L5 Cil. 3.5 L	8973159651	AC218	 912mm
	2636 GMCAC	Colorado (Luv D-Max) 4x2 Gasolina 2005...	L4 Cil. 2.5 L	8973629490	AC218	 890mm

Automóvil - Suv - Van - Pickup - Camiones Pesados - Ligeros



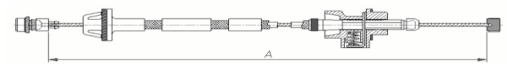
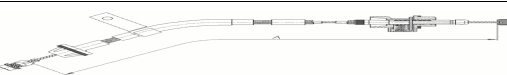
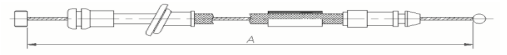
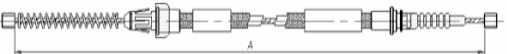



IMPORTANTE. Evite devoluciones o reclamos. Identifique previamente: marca, modelo y año del vehículo. En caso de duda, **CONSULTE** a su asesor.

NUESTRA MISIÓN... Ser su aliado en el desarrollo y crecimiento de su negocio

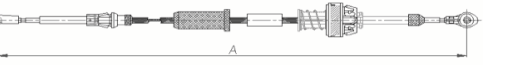
Competimos directamente con los ORIGINALES

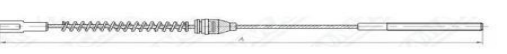
LINEA	CODIGO	MODELO	MOTOR	O.E.M	ARMADO	IMAGEN -- LONGITUD
ACCELERADOR	2551 GMCAC	Colorado (Luv D-Max) Traccion 2R Cab Simple 2005...	L4 Cil. 2.5 L	8973690080	AC218	 578mm
	2648 GMCAC	Colorado (Luv D-Max) Traccion 2R Traccion 4x4 Diesel 2005...	L4 Cil. 3.0 L	8973159682	AC221	 1150mm
APERTURA COFRE	2578 GMCCA	Colorado (Luv D-Max) Todos 2007	L5 Cil. 3.7 L	8973344362	CP19	 1905mm
FRENO DE MANO	2531 GMCFF	Colorado (Luv D-Max) Traccion 2R Traccion 4x4 Doble Cabina 2004...	L5 Cil. 3.5 L	8973633460	FP22 Trasero Izquierdo	 2015mm
	2532 GMCFF	Colorado (Luv D-Max) Traccion 2R Traccion 4x4 Doble Cabina 2004...	L5 Cil. 3.5 L	8973680690	FP22 Trasero Derecho	 1990mm
	2923 GMCFF	Colorado (Luv D-Max) Traccion 4x4 Diesel Cabina Doble 4x2 2004-2011	L5 Cil. 3.7 L L4 Cil. 2.9 L	95625136 95625134	FP343 Trasero Derecho	 1958mm
	2924 GMCFF	Colorado (Luv D-Max) 4x4 Diesel Cabina Doble; 4x2 Diesel Cabina Sencilla 2004-2011	L5 Cil. 3.7 L L4 Cil. 2.9 L	95625133 95625135	FP343 Trasero Izquierdo	 1940mm

CHEVROLET - CORSA

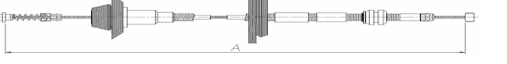
SELECTOR CAMBIOS	2157 GMCSC	Corsa todos 2002 - 2003 T/Automática	L4 Cil. 1.8 L	90523047 Z3508FHP	SC37	 1254mm
FRENO DE MANO	206 CORF	Corsa todos	L4 Cil. 1.6 L	90445985	FP15 Trasero Izquierdo	 1375mm
FRENO DE MANO	207 CORF	Corsa todos	L4 Cil. 1.6 L	90445986 0522614 0522642	FP14 Trasero Derecho	 1090mm
FRENO DE MANO	3995 CHEFP	Corsa 2002-2007	1.4L 1.8L	93393825	FP411	 209mm
VELOCIMETRO	677 GMCVZ	Corsa 2000-2008	L4 Cil. 1.4 L 1.6 L 1.8 L	93231079	VZ53	 860mm
ACCELERADOR	3322 GMCAC	Corsa 1993-2002	L4 Cil. 2.0 L	90411037 847061	AC7	 835mm
	2738 GMCAC	Corsa 2004...	L4 Cil. 1.6 L 1.8 L	93386271	AC225	 759mm





Encino 1287 col. del Fresno Guadalajara Jal.

Automóvil - Suv - Van - Pickup - Camiones Pesados - Ligeros

IMPORTANTE. Evite devoluciones o reclamos. Identifique previamente: marca, modelo y año del vehículo. En caso de duda, **CONSULTE** a su asesor.

NUESTRA MISIÓN... Ser su aliado en el desarrollo y crecimiento de su negocio

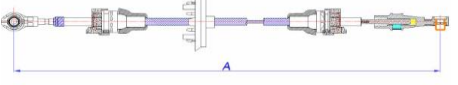
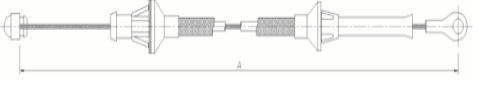
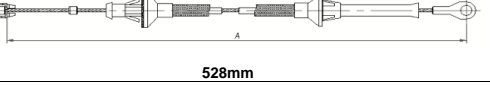
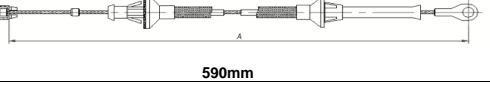
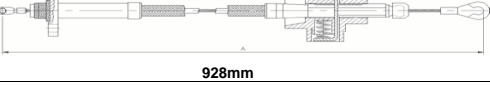
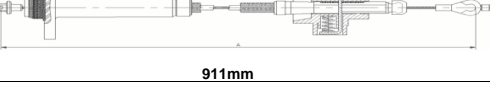
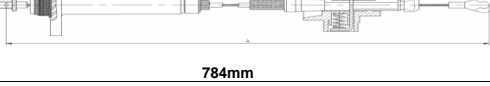
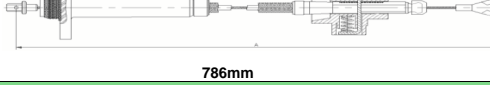
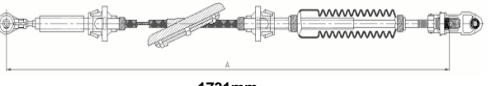
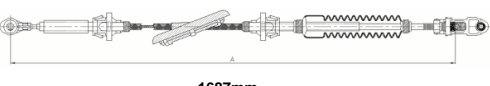
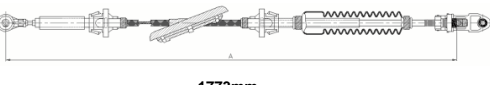
Competimos directamente con los ORIGINALES









LINEA	CODIGO	MODELO	MOTOR	O.E.M	ARMADO	IMAGEN -- LONGITUD
CHEVROLET - CORVETTE						
SELECTOR CAMBIOS	3541 GMSCC	Corvette 1984-1995 T/Automática	V8 Cil. 5.7 L	14060120	SC1	 764mm
SELECTOR CAMBIOS	4291 CHESC	Corvette 2000.. T/Automática	0	12561688	SC151	 1012mm
CHEVROLET - CRUZE						
SELECTOR CAMBIOS	4318 CHESC	Cruze 2011-2016 T/Automática	1.4 L	23273609	SC158	 1393mm
CHEVROLET - EL CAMINO						
ACELERADOR	2208 GMCAC	El Camino 1974-1984	V6 Cil. 3.8 L	1258156	AC231	 514mm
	1831 GMCAC	El Camino 1978 - 1984	V6 Cil. 3.3 L 3.8 L	1258156	AC1	 528mm
	1539 GMCA	El Camino 1975 - 1988	V8 Cil. 5.0 L 5.7 L	1254180	AC1	 590mm
SOBREMARCHA	1508 GMSB	El Camino THM250C 1981	V8 Cil. 5.0 L	25507541	SB19	 928mm
	1620 GMSB	El Camino THM200-4R 1984	0	25507550	SB2	 911mm
	1364 SBUN	El Camino THM 200C 1984...	0	25505175, K65950U	SB2	 784mm
	2291 GMCSB	El Camino THM200C 1985-1987	V6 Cil. 4.3 L	25521267	SB2	 786mm
CHEVROLET - EXPRESS						
SELECTOR CAMBIOS	3693 GMSCC	Express 2500, 3500 Gasolina 1996-2002 T/Automática	V8 Cil. 5.7 L	15772245	SC46	 1731mm
	3694 GMSCC	Express 1500,2500 Gasolina 1996-2002 T/Automática	V6 Cil. 4.3 L V8 Cil. 5.0 L 5.7 L	15772244	SC46	 1687mm
	3692 GMSCC	Express 2500, 3500 1996-2002 T/Automática	V8 Cil. 6.5 L	15772247	SC46	 1773mm
ACELERADOR	3984 CHEAC	Express 1500, 2500, 3500 1996-2000.	0	15013056	CA-9119	 1201mm

Automóvil - Suv - Van - Pickup - Camiones Pesados - Ligeros

IMPORTANTE. Evite devoluciones o reclamos. Identifique previamente: marca, modelo y año del vehículo. En caso de duda, **CONSULTE** a su asesor.

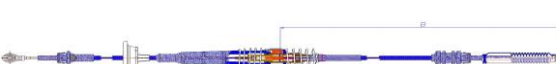
NUESTRA MISIÓN... Ser su aliado en el desarrollo y crecimiento de su negocio

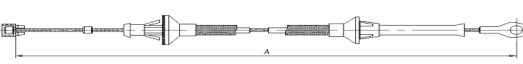
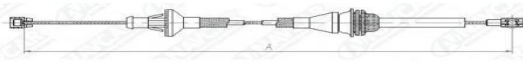
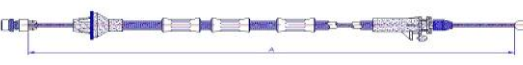
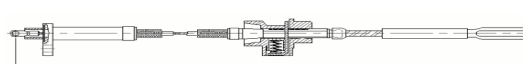
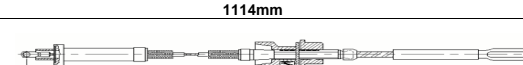
Competimos directamente con los ORIGINALES

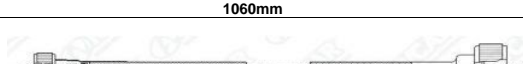
LINEA	CODIGO	MODELO	MOTOR	O.E.M	ARMADO	IMAGEN -- LONGITUD
CHEVROLET - EQUINOX						
SELECTOR CAMBIOS	4236 GMCSC	Equinox 2010-2017	2.4L 3.0L	23295736	SC138	 1646mm
CHEVROLET - IMPALA						
SELECTOR CAMBIOS	3446 GMCSC	Impala 2002-2007 T/Automática	V6 Cil. 3.6 L	15873762	SC58 Tramo Superior	 1872mm
	3449 GMCSC	Impala 2002-2007 T/Automática	V6 Cil. 3.6 L	15873759	SC57 Tramo Inferior	 1024mm
	3452 GMCSC	Impala GT 2007 - 2011 T/Automática	V6 Cil. 3.6 L	25940463	SC57 Tramo Inferior	 1020mm
	3455 GMCSC	Impala 2002-2007 T/Automática	0	12458109	SC59	 2889mm
ACELERADOR	3447 GMCAC	Impala 1999-2001	V6 Cil. 3.1 L	12567435 12554160	AC248	 1633mm
	353 ECAA	Impala 1975...	V8 Cil. 5.7 L	1252955	AC1	 521mm
	1827 GMCAC	Impala 1968 - 1969	V6	336975	AC125	 588mm
	3929 CHEAC	Impala 2000 - 2005	V6 Cil. 3.4 L	12567432	AC255	 1705mm
SOBREMARCHA	559 CHSB	Impala THM350 1978-1979	0	1262618	SB3	 1114mm
SOBREMARCHA	553 CHSB	Impala TH350	0	342486	SB3	 1005mm
SOBREMARCHA	840 CHSB	Impala TH700 1982-1988	0	25515598	SB2	 1060mm
VELOCIMETRO	2169 GMCVU	Impala 1967	0	25032876	VZ80 Tramo Superior	 966mm
CHEVROLET - K100 - K200 - K300						

Automóvil - Suv - Van - Pickup - Camiones Pesados - Ligeros





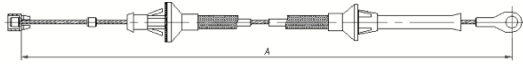
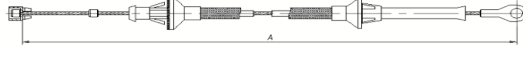
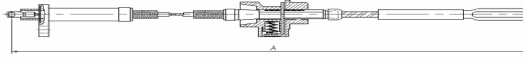
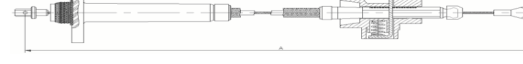

IMPORTANTE. Evite devoluciones o reclamos. Identifique previamente: marca, modelo y año del vehículo. En caso de duda, **CONSULTE** a su asesor.

NUESTRA MISIÓN... Ser su aliado en el desarrollo y crecimiento de su negocio



Competimos directamente con los ORIGINALES

LINEA	CODIGO	MODELO	MOTOR	O.E.M	ARMADO	IMAGEN -- LONGITUD
ACELERADOR	1830 GMCAC	K100 / K200 Series Trucks 1975 - 1978	V6 Cil. 4.1 L	1248073	AC1	 493mm
	1549 GMCA	K100 / K200 Series Camioneta 1977 - 1979	V6 Cil. 4.1 L	1248083	AC1	 498mm
SOBREMARCHA	559 CHSB	K100 / K300 Camionetas y Van W/THM350 292 1978	0	1262618	SB3	 1114mm
	1622 GMSB	K100 4x4 1983 - 1984	0	25515600	SB2	 1185mm

CHEVROLET - KODIAK

EMBRAGUE	2650 KODEM	Kodiak B70 1994...	0	15959453	EM1 (Largo)	 2573mm
	2649 KODEM	Kodiak Diesel / Gasolina 1994...	0	15959451 15998935	EM1 (Corto)	 2267mm
FRENO DE MANO	3201 GMCFP	Kodiak C5500, C60, C70 1990	0	18037416	FP354 Principal	 1905mm
	3111 GMCFP	Kodiak C60, C70 1993-1996	0	18037383	FP354 Principal	 1800mm
ACELERADOR	139 KODA	Kodiak Gasolina 1994...	0	15668249	AC9	 1130mm
	126 CHEA	Kodiak C60	0	1248092	AC1	 1747mm

CHEVROLET - LUMINA

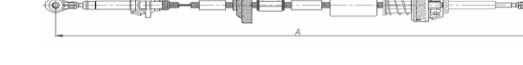
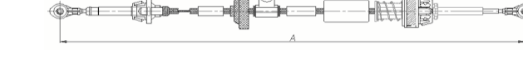



CONJUNTO SELECTOR CAMBIOS	3455 GMCSC	Lumina 2002-2007 T/Automática	0	12458109	SC59	 2889mm
SELECTOR CAMBIOS	2152 GMCSC	Lumina 1996 - 1997 T/Automática	V6 Cil. 3.1 L	12553934	SC32	 1890mm
	2153 GMCSC	Lumina 1996 - 1997 T/Automática	V6 Cil. 3.1 L	12554970	SC28	 2753mm
	2154 GMCSC	Lumina 1996 - 1997 T/Automática	V6 Cil. 3.1 L	12553933	SC28	 2430mm

Automóvil - Suv - Van - Pickup - Camiones Pesados - Ligeros

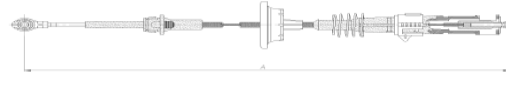

IMPORTANTE. Evite devoluciones o reclamos. Identifique previamente: marca, modelo y año del vehículo. En caso de duda, **CONSULTE** a su asesor.

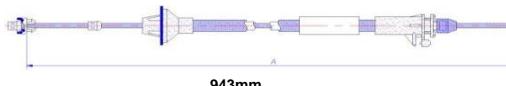
NUESTRA MISIÓN... Ser su aliado en el desarrollo y crecimiento de su negocio

Competimos directamente con los ORIGINALES

LINEA	CODIGO	MODELO	MOTOR	O.E.M	ARMADO	IMAGEN -- LONGITUD
SELECTOR CAMBIOS	3446 GMCSC	Lumina 2002-2007 T/Automática	V6 Cil. 3.6 L	15873762	SC58 Tramo Superior	 1872mm
	3449 GMCSC	Lumina 2002-2007 T/Automática	V6 Cil. 3.6 L	15873759	SC57 Tramo Inferior	 1024mm
ACELERADOR	3448 GMCAC	Lumina 1993-1995	V6 Cil. 3.1 L	12554626	AC249	 943mm
	3447 GMCAC	Lumina 1999-2001	V6 Cil. 3.1 L	12567435 12554160	AC248	 1633mm
	3567 GMCAC	Lumina 1997 - 1999	V6 Cil. 3.8 L	12557988	AC254	 1646mm

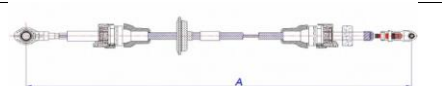
CHEVROLET - MALIBU

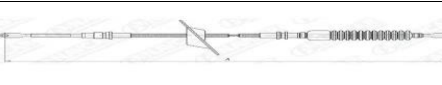
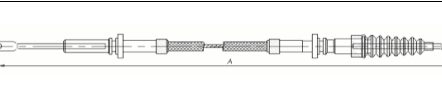
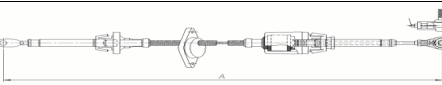
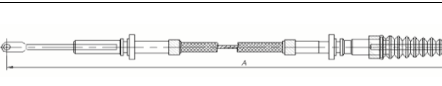
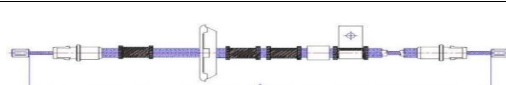
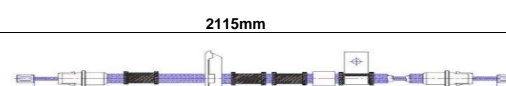



SELECTOR CAMBIOS	4246 CHESC	Malibu 1997-2001 T/Automática	3.1L	22678830	SC142	 2623mm
SELECTOR CAMBIOS	4233 CHESC	Malibu 2008-2012 T/Automática	2.4L	23238000	SC139	 1097mm
SELECTOR CAMBIOS	4367 CHESC	Malibu 2008-2010 T/Automática	2.2L 2.4L 3.5L 3.6L	25974057 25910202 20922586	SC139	 1118mm
SELECTOR CAMBIOS	476 MASE	Malibu 1977 T/Automática	0	485928	SC1	 800mm
SELECTOR CAMBIOS	625 MOSE	Malibu T/Automática	V6 Cil. 3.1 L	22500581	SC5	 673mm
	1768 GMCSC	Malibu 1982-1983 T/Automática	L4 Cil. 1.4 L	10022405	SC15	 1265mm
	2572 GMCSC	Malibu TH-200 1984-1988 T/Automática	V6 Cil. 3.1 L	10026082	SC5	 675mm
FRENO DE MANO	3746 GMCFP	Malibu LTZ, LT, LS, Hybrid 2008-2012	L4 Cil. 2.4 L V6 Cil. 3.6 L	20860177	FP370 Trasero Derecho	 2115mm
FRENO DE MANO	3754 GMCFP	Malibu LTZ, LT, LS, Hybrid 2008-2012	L4 Cil. 2.4 L V6 Cil. 3.6 L	25974278	FP370 Trasero Izquierdo	 2116mm

Automóvil - Suv - Van - Pickup - Camiones Pesados - Ligeros

¡IMPORTANTE. Evite devoluciones o reclamos. Identifique previamente: marca, modelo y año del vehículo. En caso de duda, **CONSULTE** a su asesor.

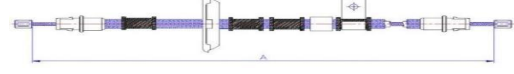
NUESTRA MISIÓN... Ser su aliado en el desarrollo y crecimiento de su negocio

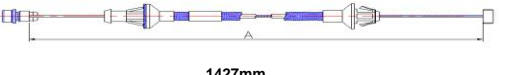
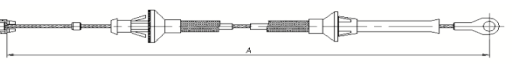
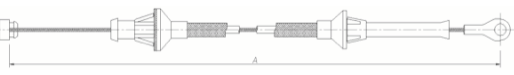
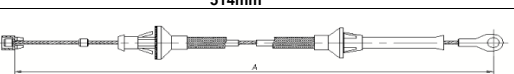
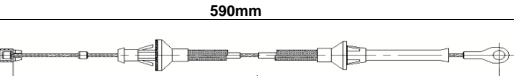
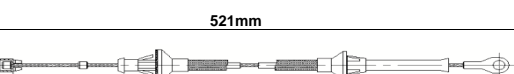
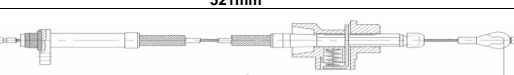
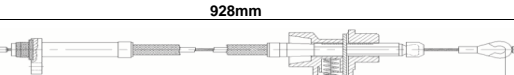
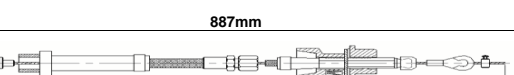
Competimos directamente con los ORIGINALES

LINEA	CODIGO	MODELO	MOTOR	O.E.M	ARMADO	IMAGEN -- LONGITUD
FRENO DE MANO	3753 GMCFP	Malibu LTZ, LT, LS 2008-2012	L4 Cil. 2.4 L	20860176	FP370 Trasero Derecho	 2100mm
	3747 GMCFP	Malibu LTZ, LT, LS Gas 2008-2012	L4 Cil. 2.4 L	25974276	FP370 Trasero Izquierdo	 2101mm
LIBERADOR FRENO	952 EMAF	Malibu... 1978	V8 Cil. 5.7 L	0	LF1	 297mm
	935 EMAF	Malibu 1978 - 1983	V8 Cil. 5.7 L	1252970	LF1	 171mm
ACELERADOR	3560 GMCAC	Malibu 1997-2004	V6 Cil. 3.1 L	22619741	AC258	 1427mm
	1831 GMCAC	Malibu 1978 - 1984	V6 Cil. 3.3 L 3.8 L	1258156	AC1	 528mm
	2208 GMCAC	Malibu 280,229 1974-1984	V6 Cil. 3.8 L	1258156	AC231	 514mm
	1539 GMCA	Malibu 1975 - 1988	V8 Cil. 5.0 L 5.7 L	1254180	AC1	 590mm
	353 ECAA	Malibu 1975	V8 Cil. 5.7 L	1252955	AC1	 521mm
	475 EMAA	Malibu	V8 Cil.	1248077	AC1	 521mm
SOBREMARCHA	1508 GMSB	Malibu THM250C 1981	V8 Cil. 5.0 L	25507541	SB19	 928mm
	556 CHSB	Malibu M231/350	0	1262652	SB19	 887mm
SOBREMARCHA UNIV.	1367 SBUN	Malibu w/200 1978 - 1988	0	0	SB18	 1255mm
	1368 SBUN	Malibu w/350 1975 - 1984	0	0	SB17	 1110mm

CHEVROLET - MATIZ Gen-1 - Gen-2





KIT SELECTOR Y	2050 GMCCC	Matiz Gen-1 2004-2005 T/Standar	L4 Cil. 1.0 L	96333366	CC11	 A=1030mm/B=970mm
-------------------	----------------------	--	------------------	----------	------	--

Automóvil - SUV - Van - Pickup - Camiones Pesados - Ligeros

¡IMPORTANTE! Evite devoluciones o reclamos. Identifique previamente: marca, modelo y año del vehículo. En caso de duda, **CONSULTE** a su asesor.

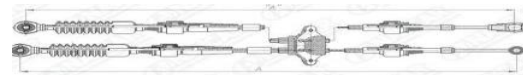
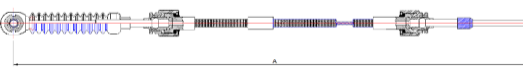
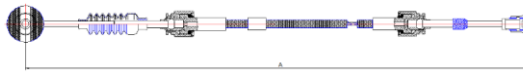
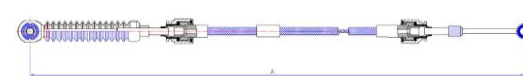
NUESTRA MISIÓN... Ser su aliado en el desarrollo y crecimiento de su negocio

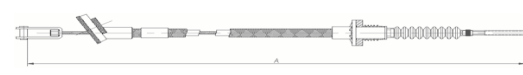
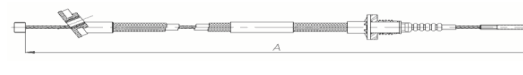
Competimos directamente con los ORIGINALES

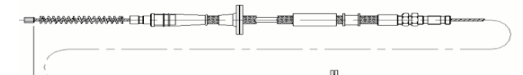
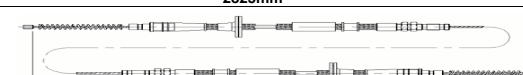
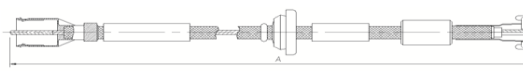
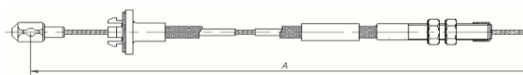
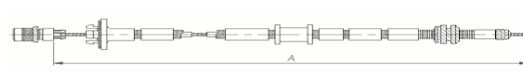
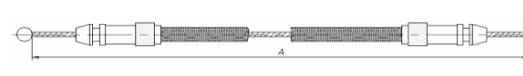
LINEA	CODIGO	MODELO	MOTOR	O.E.M	ARMADO	IMAGEN -- LONGITUD
NEUTRO CAMBIOS	2379 GMCCC	Matiz Gen-2 2006-2011 T/Standar	L4 Cil. 1.0 L	96495488	CC19	 A=1058mm/B=999mm
NEUTRO CAMBIOS	2050SM GMCCC	Matiz Gen-1 2004-2005 T/Standar	L4 CIL. 1.0L	96333366	CC11-S	 A=1030mm
SELECTOR CAMBIOS	2050CM GMCCC	Matiz Gen-1 2004-2005 T/Standar	L4 CIL. 1.0L	96333366	CC11-C	 B=970mm
NEUTRAL CAMBIOS	2379SM GMCCC	Matiz Gen-2 2006-2011 T/Standar	L4 CIL. 1.0L	96495488	CC19-S	 A=1058mm
SELECTOR CAMBIOS	2379CM GMCCC	Matiz Gen-2 2006-2011 T/Standar	L4 CIL. 1.0L	96495488	CC19-C	 B=999mm
EMBRAGUE	2052 GMCEM	Matiz Gen-1 2004-2005	L4 Cil. 1.0 L	96336061	EM12	 845mm
	2373 GMCEM	Matiz Gen-2 2006-2011	L4 Cil. 1.0 L	25187023	EM101	 835mm
	2718 GMCEM	Matiz Gen-2 2006-2012	L4 Cil. 1.0 L	96590793	EM120 Con deslizador	 832mm
FRENO DE MANO	1886 DAEFP	Matiz Gen 1 2004-2005	L4 Cil. 1.0 L	96316682	FP32 Único	 2825mm
	2526 GMCFP	Matiz Gen 2 Todos 2006...	L4 Cil. 1.0 L	96666925	FP32 Traseros	 3020mm
VELOCIMETRO	2053 GMCVZ	Matiz Gen-1 - Gen-2	L4 Cil. 1.0 L	96347901	VZ66	 925mm
ACELERADOR	2049 GMCAC	Matiz Gen-1 2004-2005	L4 Cil. 1.0 L	96288183	AC20	 1430mm
ACELERADOR	2378 GMCAC	Matiz Gen-2 2006-2011	L4 Cil. 1.0 L	96490240	AC198	 1507mm
APERTURA CAJUELA	2051 GMCAB	Matiz Gen-1 - Gen-2	L4 Cil. 1.0 L	96315587	AB2	 2922mm

Automóvil - Suv - Van - Pickup - Camiones Pesados - Ligeros







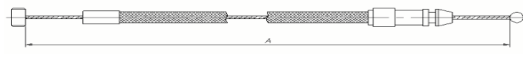
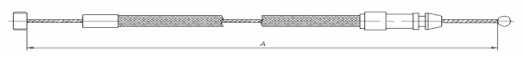

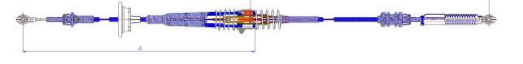

IMPORTANTE. Evite devoluciones o reclamos. Identifique previamente: marca, modelo y año del vehículo. En caso de duda, **CONSULTE** a su asesor.

NUESTRA MISIÓN... Ser su aliado en el desarrollo y crecimiento de su negocio

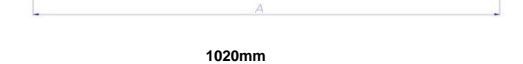
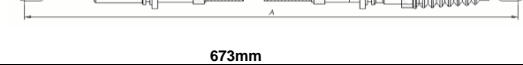
Competimos directamente con los ORIGINALES

LINEA	CODIGO	MODELO	MOTOR	O.E.M	ARMADO	IMAGEN -- LONGITUD
APERTURA COFRE	2076 GMCCA	Matiz Gen-1 2004-2005	L4 Cil. 1.0 L	96314531	CP4	 1672mm
	3381 GMCCA	Matiz Gen-2 2006-2015	L4 Cil. 1.0 L	96875089	CP4	 1528mm

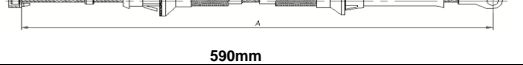
CHEVROLET - MONTE CARLO

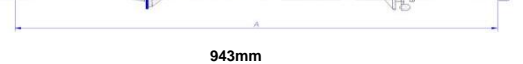
CONJUNTO SELECTOR CAMBIOS	3455 GMSCC	Monte Carlo 2002-2007 T/Automática	0	12458109	SC59	 2889mm
SELECTOR CAMBIOS	3446 GMSCC	Monte Carlo 2002-2007 T/Automática	V6 Cil. 3.6 L	15873762	SC58 Tramo Superior	 1872mm
	3449 GMSCC	Monte Carlo 2002-2007 T/Automática	V6 Cil. 3.6 L	15873759	SC57 Tramo Inferior	 1024mm
	3452 GMSCC	Monte Carlo GT 2007 - 2011 T/Automática	V6 Cil. 3.6 L	25940463	SC57 Tramo Inferior	 1020mm
	625 MOSE	Monte Carlo T/Automática	V6 Cil. 3.1 L	22500581	SC5	 673mm
	2572 GMSCC	Monte Carlo TH-200-4R 1984-1988 T/Automática	V6 Cil. 3.1 L	10026082	SC5	 680mm
LIBERADOR FRENO	935 EMAF	Monte Carlo 1978 - 1983	V8 Cil. 5.7 L	1252970	LF1	 171mm
	952 EMAF	Monte Carlo ...1978	V8 Cil. 5.7 L	0	LF1	 297mm
ACELERADOR	2208 GMCAC	Monte Carlo 1974-1984	V6 Cil. 3.8 L	1258156	AC231	 514mm
	1539 GMCA	Monte Carlo 1975 - 1988	V8 Cil. 5.0 L 5.7 L	1254180	AC1	 590mm
ACELERADOR	1831 GMCAC	Monte Carlo 1978 - 1984	V6 Cil. 3.3 L 3.8 L	1258156	AC1	 528mm
	3448 GMCAC	Monte Carlo 1993-1995	V6 Cil. 3.1 L	12554626	AC249	 943mm
	3567 GMCAC	Monte Carlo 1997 - 1999	V6 Cil. 3.8 L	12557988	AC254	 1646mm

Automóvil - Suv - Van - Pickup - Camiones Pesados - Ligeros



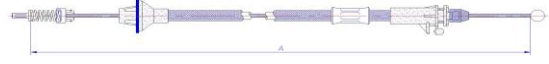
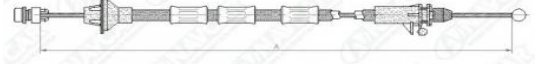
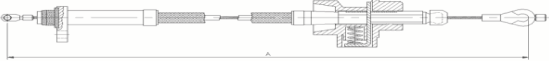
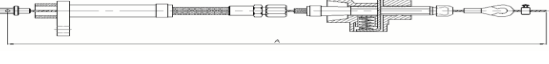
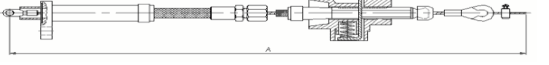

IMPORTANTE. Evite devoluciones o reclamos. Identifique previamente: marca, modelo y año del vehículo. En caso de duda, **CONSULTE** a su asesor.

NUESTRA MISIÓN... Ser su aliado en el desarrollo y crecimiento de su negocio

Competimos directamente con los ORIGINALES

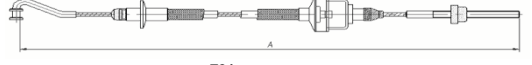
LINEA	CODIGO	MODELO	MOTOR	O.E.M	ARMADO	IMAGEN -- LONGITUD
	3447 GMCAC	Monte Carlo 1999-2001	V6 Cil. 3.1 L	12567435 /12554160	AC248	 1633mm
ACELERADOR	3929 CHEAC	Monte Carlo 2000 - 2005	V6 Cil. 3.4 L	12567432	AC255	 1705mm
SOBREMARCHA	556 CHSB	Monte Carlo M231/350	0	1262652	SB19	 887mm
	1367 SBUN	Monte Carlo 1978 - 1988	0	0	SB18	 1255mm
	1368 SBUN	Monte Carlo w/350 1975 - 1984	0	0	SB17	 1110mm

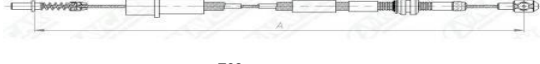

CHEVROLET - MONZA

EMBRAGUE	136 CHME	Monza ...1992	L4 Cil. 1.8 L	94638953	EM8	 791mm
	1809 GMCEM	Monza todos 1993...	L4 Cil. 1.8 L	93201971	EM8	 842mm
ACELERADOR	281 CHMA	Monza 1985 - 1987	L4 Cil. 1.2 L	94626707	AC7	 769mm
	3322 GMCAC	Monza 1996-2011	L4 Cil. 2.0 L	90411037 847061	AC7	 835mm

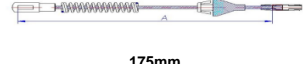
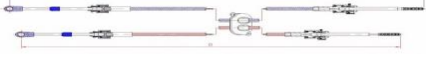
CHEVROLET - ONIX

FRENO DE MANO	4171 CHEFP	Onix 2013-2019	1.4L 1.8L	95492584	FP474	 175mm
KIT SELECTOR Y NEUTRAL CAMBIOS	4172 CHECC	Onix 2016...	1.4L	25187855 25186044 25185111 25187851	CC115	 A=1128mm/B=1096mm

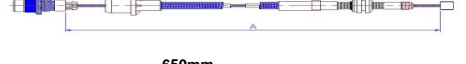
CHEVROLET - OPTRA

ACELERADOR	3496 GMCAC	Optra 2005 - 2010	L4 Cil. 1.4 L 1.6 L	96553898	AC252	 750mm
	3497 GMCAC	Optra 2005 - 2010	L4 Cil. 1.8 L	96553902	AC252	 650mm
APERTURA COFRE	2928 GMCCA	Optra todos	L4 Cil. 1.8 L	96308156	CP4	 1857mm









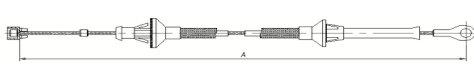
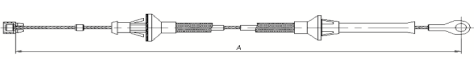

Encino 1287 col. del Fresno Guadalajara Jal.

Automóvil - Suv - Van - Pickup - Camiones Pesados - Ligeros

IMPORTANTE. Evite devoluciones o reclamos. Identifique previamente: marca, modelo y año del vehículo. En caso de duda, **CONSULTE** a su asesor.

NUESTRA MISIÓN... Ser su aliado en el desarrollo y crecimiento de su negocio

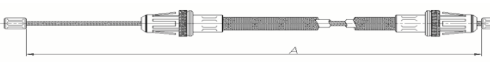
Competimos directamente con los ORIGINALES

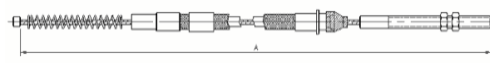
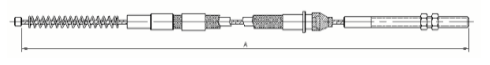













LINEA	CODIGO	MODELO	MOTOR	O.E.M	ARMADO	IMAGEN -- LONGITUD
CHEVROLET - P30						
VELOCIMETRO	695 GMCVZ	P-30 1979 - 1984	0	6478230	VZ2	 2033mm
ACELERADOR	3409 GMCAC	P30 1992-1995	V6 Cil. 4.3 L	15990937	AC246	 1703mm
	3797 GMCAC	P30 Diesel - Gasolina 1993-1996	V8 Cil. 5.7 L 6.5 L V6 Cil. 4.3 L	15996317	AC1	 1702mm
	126 CHEA	P30 1985-1989	0	1248092	AC1	 1747mm
CHEVROLET - S10						
SELECTOR CAMBIOS	3402 GMCSC	S10 Traccion 4x4 1995-1997 T/Automática	V6 Cil. 4.3 L	15721261	SC27	 2576mm
	3807 GMCSC	S10 1998-2005 T/Automática	4 Cil. 2.2 L	15189203	SC27	 2861mm
	4007 GMCSC	S10 1999-2004 T/Automática	V6 Cil. 2.5 L 4.3 L	15189198	SC27	 2523mm
	3866 GMCSC	S10 1998-2005 T/Automática	V6 Cil. 4.3 L L4 Cil. 2.2 L	15189199	SC27	 2042mm
EMBRAGUE	2277 GMCEM	S10 1982-1983	V6 Cil. 4.3 L	14030848	EM94 Con Tope	 440mm
	2276 GMCEM	S10 1982-1983	V6 Cil. 4.3 L	14062618	EM93 Con Tornillo	 188mm
FRENO DE MANO	2621 GMCFP	S10 1998 - 2001	V6 Cil. 4.3 L	15724598	FP240 Principal	 923mm
	1641 GMCF	S10 1995 - 1997	L4 Cil. 2.2 L V6 Cil. 4.3 L	93213407	FP155 Trasero Derecho	 1640mm
	1642 GMCF	S10 1995 - 1997	L4 Cil. 2.2 L V6 Cil. 4.3 L	93213406	FP149 Trasero Izquierdo	 2397mm
	1638 GMCF	S10 1997...	L4 Cil. 2.2 L V6 Cil. 4.3 L	93259375	FP149 Trasero Izquierdo	 1345mm

Automóvil - Suv - Van - Pickup - Camiones Pesados - Ligeros

IMPORTANTE. Evite devoluciones o reclamos. Identifique previamente: marca, modelo y año del vehículo. En caso de duda, **CONSULTE** a su asesor.

NUESTRA MISIÓN... Ser su aliado en el desarrollo y crecimiento de su negocio

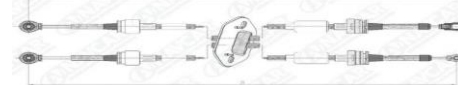
Competimos directamente con los ORIGINALES





LINEA	CODIGO	MODELO	MOTOR	O.E.M	ARMADO	IMAGEN -- LONGITUD
	1637 GMCF	S10 1997...	L4 Cil. 2.2 L V6 Cil. 4.3 L	93248610	FP155 Trasero Derecho	 2755mm
	3108 GMCFP	S10 Traccion 4x4 1996-1997	V6 Cil. 4.3 L	15709831 15741310	FP272 Trasero Izquierdo	 1758mm
LIBERADOR FRENO	1635 GMCF	S10 1995	V6 Cil. 4.3 L	93228406	LF1	 377mm
ACELERADOR	1556 GMCA	S10 1982-1986	L4 2.5 L	15590109 15592356	AC1	 1023 mm
	2042 GMCAC	S10 1992-1997	V6 Cil. 4.3 L	15959410 15693481	AC116	 886mm
	1551 GMCA	S10 1982 - 1985	V6 Cil. 2.8 L	14036110	AC1	 760mm
	1561 GMCA	S10 1986 - 1991	V6 Cil. 2.8 L	15622471	AC1	 855mm
	1524 GMCA	S10 Motor 262Z 1988 - 1990	V6 Cil. 4.3 L	15622442	AC1	 795mm
	3930 CHEAC	S10 2000 - 2003	L4 Cil. 2.2 L	15205658	AC247	 706mm
APERTURA COFRE	3780 GMCCA	S10 1999-2006	L4 Cil. V6 Cil.	0	CP9	 1800mm
SOBREMARCHA	2036 GMCSB	S10 1992	V6 Cil. 4.3 L	10142019	SB2	 1067mm
	2040 GMCSB	S10 Traccion 2R 1991	0	10111682	SB2	 1028mm
	2298 GMCSB	S10	V6 Cil. 4.3 L	0	SB2	 782mm
CHEVROLET SAIL						
KIT SELECTOR Y NEUTRAL CAMBIOS	3841 GMCCC	Sail 2012 T/Estándar	0	24105496	CC40	 A=1137mm/B=1109mm
EMBRAGUE	3579 GMCEM	Sail 2012.	0	24105069	EM134	 952mm

Automóvil - Suv - Van - Pickup - Camiones Pesados - Ligeros



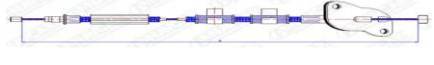

IMPORTANTE. Evite devoluciones o reclamos. Identifique previamente: marca, modelo y año del vehículo. En caso de duda, **CONSULTE** a su asesor.

NUESTRA MISIÓN... Ser su aliado en el desarrollo y crecimiento de su negocio

Competimos directamente con los ORIGINALES

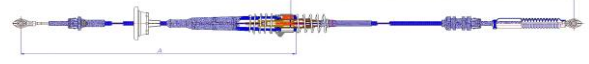
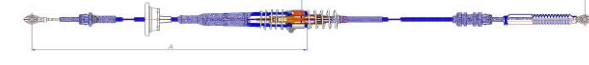
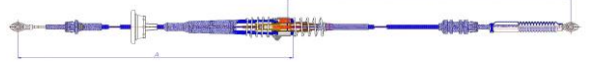
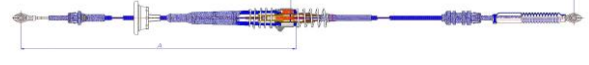
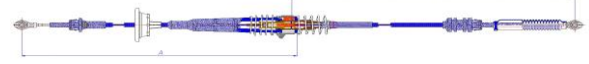
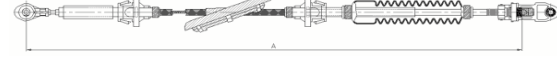
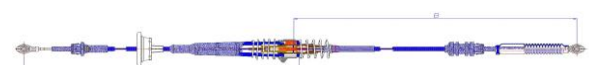
LINEA	CODIGO	MODELO	MOTOR	O.E.M	ARMADO	IMAGEN -- LONGITUD
FRENO DE MANO	3742 GMCFP	Sail 2012.	0	9046445	FP393 Principal	 1260mm
	3743 GMCFP	Sail 2012.	0	9022221	FP367 Trasero Derecho	 460mm
	3744 GMCFP	Sail 2012.	0	9022220	FP368 Trasero Izquierdo	 987mm
APERTURA COFRE	3854 GMCCA	Sail 2013-2015	0	9061797	CP4	 1715mm

CHEVROLET - SILVERADO











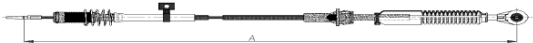

CONJUNTO SELECTOR CAMBIOS	3430 GMSCC	Silverado 1500, 2500, 3500. Traccion 2R Traccion 4x4 2002	4.3 L 4.8 L 5.3 L 6.0 L	88967320	SC59	 3531mm
	3382 GMSCC	Silverado 1500, 2500 LS, LT 2000 y 2007 T/Automática	4.8 L 5.3 L 6.0 L	12477640	SC59	 3509mm
	3439 GMSCC	Silverado 1500, 2500 2000-2007 T/Automática	4.3 L 4.8 L 5.3 L 6.0 L	12477639	SC59	 3332mm
CONJUNTO SELECTOR CAMBIOS	3442 GMSCC	Silverado 2001-2006 T/Automática	0	19167308	SC59	 3241mm
	3437 GMSCC	Silverado 1500, 2500, 3500 2000-2006 T/Automática	V8 Cil. 5.3 L	88967321	SC59	 3332mm
	2914 GMSCC	Silverado 1500, 2500 1999-2002 T/Automática	V6 Cil. 4.3 L	15037353	SC46	 2874mm
	4306 GMSCC	Silverado 2007-2014 T/Automática	V8 Cil. 6.8 L	0	SC77	 3391mm
	3466 GMSCC	Silverado 1500; 2500; 3500 2007-2009 T/Automática	V8 Cil. 5.3 L	20787607	SC60 Tramo Inferior	 1397mm
	3467 GMSCC	Silverado 1500; 2500; 3500 2007-2012 T/Automática	V8 Cil. 5.3 L	20787610	SC60 Tramo Inferior	 1446mm
	3480 GMSCC	Silverado Traccion 2R Crew Cab 2009-2011 T/Automática	V8 Cil. 5.3 L	20787611	SC60 Tramo Inferior	 1445mm

Automóvil - Suv - Van - Pickup - Camiones Pesados - Ligeros

IMPORTANTE. Evite devoluciones o reclamos. Identifique previamente: marca, modelo y año del vehículo. En caso de duda, **CONSULTE** a su asesor.

NUESTRA MISIÓN... Ser su aliado en el desarrollo y crecimiento de su negocio

Competimos directamente con los ORIGINALES







LINEA	CODIGO	MODELO	MOTOR	O.E.M	ARMADO	IMAGEN -- LONGITUD
SELECTOR CAMBIOS	3479 GMSCC	Silverado 1500 Traccion 2R 2009-2012 T/Automática	V8 Cil. 5.3 L	20787609	SC60 Tramo Inferior	 1395mm
	3483 GMSCC	Silverado Traccion 4x4 1500 2007-2011 T/Automática	V8 Cil. 5.3 L	20787608	SC60 Tramo Inferior	 1505mm
	3465 GMSCC	Silverado Traccion 4x4 2500, 3500 2007-2012 T/Automática	V8 Cil. 5.3 L	20787606	SC60 Tramo Inferior	 1620mm
	3440 GMSCC	Silverado 1999-2007 T/Automática	V8 Cil. 5.3 L	25836132	SC57 Tramo Inferior	 1623mm
	3438 GMSCC	Silverado Traccion 2R 1999-2007 T/Automática	V8 Cil. 5.3 L	15118283	SC57 Tramo Inferior	 1446mm
	3441 GMSCC	Silverado 2001-2006 T/Automática	V8 Cil. 5.3 L	15822857	SC57 Tramo Inferior	 1355mm
	3436 GMSCC	Silverado Traccion 2R 1500, 2500, 3500 2000-2006 T/Automática	V8 Cil. 5.3 L	15784586	SC57 Tramo Inferior	 1446mm
	3435 GMSCC	Silverado Traccion 2R 1500, 2500, 3500 2000-2006 T/Automática	V8 Cil. 5.3 L	15251896	SC58 Tramo Superior	 1892mm
	3481 GMSCC	Silverado Traccion 2R 1500, Traccion 2R 1500 Crew Cab / 2007-2008 T/Automática	V8 Cil. 5.3 L	15909820	SC57 Tramo Inferior	 1445mm
	4308 GMSCC	Silverado 2016-2018 T/Automática	V8 Cil. 5.3 L	0	SC60 Tramo Inferior	 1576mm
SELECTOR CAMBIOS	4191 GMSCC	Silverado 2015-2017 T/Automática	6.0L	84507730 23174591	SC60 Tramo Inferior	 1442mm
	4193 GMSCC	Silverado 2016-2018 T/Automática	6.0L	23174587	SC60 Tramo Inferior	 1373mm

Automóvil - Suv - Van - Pickup - Camiones Pesados - Ligeros

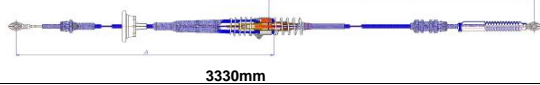
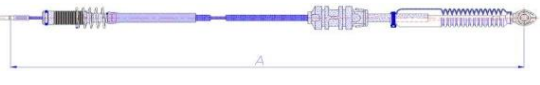
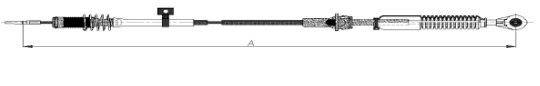
IMPORTANTE. Evite devoluciones o reclamos. Identifique previamente: marca, modelo y año del vehículo. En caso de duda, **CONSULTE** a su asesor.

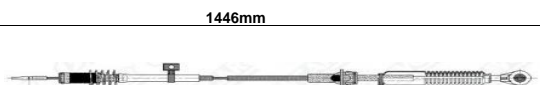
NUESTRA MISIÓN... Ser su aliado en el desarrollo y crecimiento de su negocio

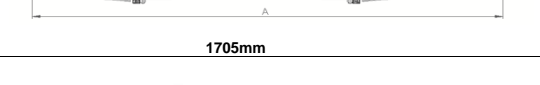
Competimos directamente con los ORIGINALES

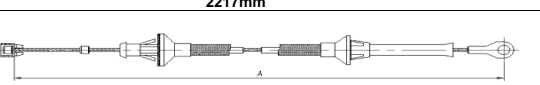
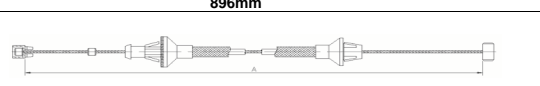
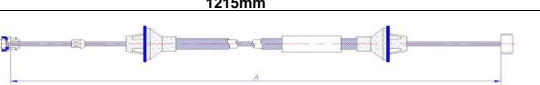
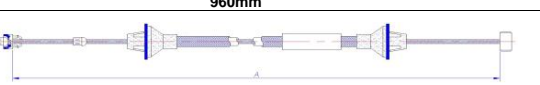







LINEA	CODIGO	MODELO	MOTOR	O.E.M	ARMADO	IMAGEN -- LONGITUD
	3482 GMCS	Silverado Traccion 2R 1500, Traccion 2R 1500 Crew Cab / 2007-2008 T/Automática	V8 Cil. 5.3 L	15203850	SC58 Tramo Superior	 1892mm
	3476 GMCS	Silverado Traccion 2R 1500, Traccion 2R 1500 Crew Cab / 2007-2008	0	15945100	SC58	 3330mm
	3434 GMCS	Silverado 4WD 1500, 2500, 3500 2000-2006 T/Automática	V8 Cil. 5.3 L	15784587	SC57 Tramo Inferior	 1645mm
	3867 GMCS	Silverado 2500 - 3500 2010 - 2014 T/Automática	0	25995571	SC60 Tramo Inferior	 1374mm
	4009 GMCS	Silverado 2016-2018 T/Automática	5.3 L 6.2 L	23174588	SC60 Tramo Inferior	 1446mm
	4011 GMCS	Silverado 2014-2015 T/Automática	5.3 L 6.0 L 6.2 L 6.6 L	23258956	SC60 Tramo Inferior	 1505mm
FRENO DE MANO	2730 GMCFP	Silverado 1500, 1500HD 2006 - 2007	V6 Cil. 4.3 L V8 Cil. 4.8 L 5.3 L	15215322	FP218	 1705mm
	3079 GMCFP	Silverado 3500 Clasica 2001-2007	V8 Cil. 6.0L, 6.6L 8.1L	15020670 15130818	FP63 Trasero Derecho	 2270mm
	3083 GMCFP	Silverado 2001 - 2007	V8 6.0L 6.6L 8.1L	15017171	FP63 Trasero Izquierdo	 2217mm
ACELERADOR	120 CHEA	Silverado 1983 - 1984	V8 Cil. 6.2 L	14000306	AC1	 896mm
	1130 CHEA	Silverado 1996...	V8 Cil. 6.2 L	15733560	AC116	 1215mm
	3445 GMCAC	Silverado 1999-2000	V8 Cil. 5.3 L	15712337 22542664 15040848	AC247	 960mm
	3928 GMCAC	Silverado 2001-2002	V8 Cil. 5.3 L	15040848	AC247	 956mm
SOPORTE COMPUERTA	3795 GMCSC	Silverado 1999 - 2007	V8 Cil. 5.3 L	16637944 16637945 88892972 88892973 88980509 88980510	CO6	 385mm

Automóvil - Suv - Van - Pickup - Camiones Pesados - Ligeros

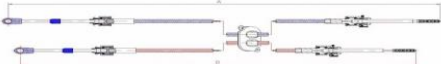
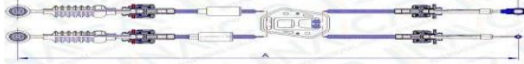
IMPORTANTE. Evite devoluciones o reclamos. Identifique previamente: marca, modelo y año del vehículo. En caso de duda, **CONSULTE** a su asesor.

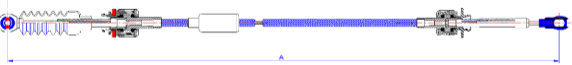
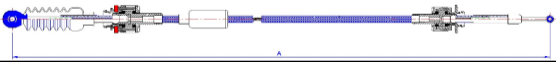
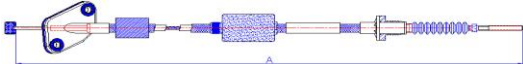
NUESTRA MISIÓN... Ser su aliado en el desarrollo y crecimiento de su negocio

Competimos directamente con los ORIGINALES

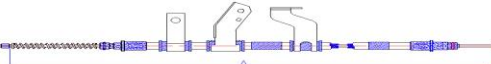
LINEA	CODIGO	MODELO	MOTOR	O.E.M	ARMADO	IMAGEN -- LONGITUD
SOPORTE CAJUELA	1702 CHEC	Silverado 1991 - 1998	V8 Cil. 6.2 L	15673251	CO1	 360mm
CHEVROLET - SONIC						
FRENO DE MANO	4171 CHEFP	Sonic 2013-2019	1.4L 1.8L	95492584	FP474	 175mm
FRENO DE MANO	4170 CHEFP	Sonic 2013-2019	1.6L	52059329	FP479Trasero Derecho/Izquierdo	 A=1400mm/B=1400mm
KIT SELECTOR Y NEUTRAL CAMBIOS	4172 CHECC	Sonic 2013-2019	1.6L	25187855 25186044 25185111 25187851	CC115	 A=1128mm/B=1096mm
CHEVROLET - SPARK 1.2 GT						
KIT SELECTOR Y NEUTRAL CAMBIOS	3982 CHECC	Spark GT, Spark Clasico 2013... T/Standar	L4 Cil. 1.2L	25189436 25198661 25196857	CC57	 A=1155mm/B=1053mm
	3720 GMCCC	Spark GT (Gen-1) 2009-2015 T/Standar	L4 Cil. 1.2L	25189435	CC57	 A=1160mm/B=1056mm
SELECTOR CAMBIOS	3720CC GMCCC	Spark GT (Gen-1) 2009-2015 T/Standar	L4 CIL. 1.6L	25189435	CC57-C	 B=1056mm
NEUTRAL CAMBIOS	3720SC GMCCC	Spark GT (Gen-1) 2009-2015 T/Standar	L4 CIL. 1.6L	25189435	CC57-S	 A=1160mm
EMBRAGUE	3543 GMCEM	Spark GT (Gen-1) 2009-2015	L4 Cil. 1.2L	25181785	EM137	 930mm
FRENO DE MANO	4003 GMCFP	Spark Gt 2010...	0	93740724	FP413 Principal	 335mm
FRENO DE MANO	2476 GMCFP	Spark 2004 - 2006	L4 Cil. 1.2L	96518596	FP32 Unico	 2828mm
	3576 GMCFP	Spark GT (Gen-1) 2009-2015	L4 Cil. 1.2L	95930044 95421244	FP345 Trasero Derecho	 1442 mm
	3577 GMCFP	Spark GT (Gen-1) 2009-2015	L4 Cil. 1.2 L	95930043	FP345 Trasero Izquierdo	 1403mm

Automóvil - Suv - Van - Pickup - Camiones Pesados - Ligeros





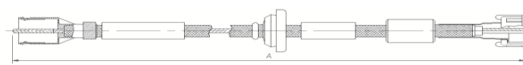
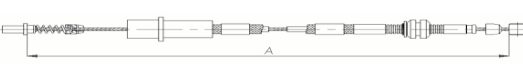
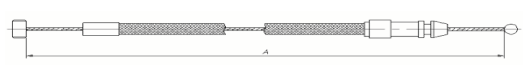

IMPORTANTE. Evite devoluciones o reclamos. Identifique previamente: marca, modelo y año del vehículo. En caso de duda, **CONSULTE** a su asesor.

NUESTRA MISIÓN... Ser su aliado en el desarrollo y crecimiento de su negocio

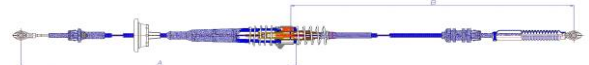
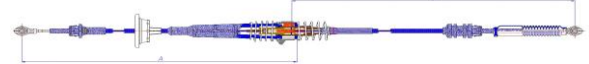
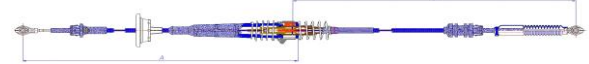
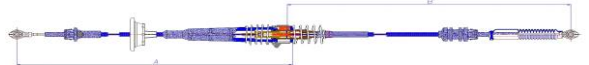
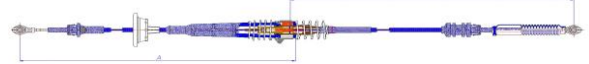
Competimos directamente con los ORIGINALES

LINEA	CODIGO	MODELO	MOTOR	O.E.M	ARMADO	IMAGEN -- LONGITUD
VELOCIMETRO	2053 GMCVZ	Spark todos 2004...	L4 Cil. 1.0 IL	96347901	VZ66	 925mm
ACELERADOR	3517 GMCAC	Spark GT (Gen-1) 2009-2015	L4 Cil. 1.2 L	25190036	AC13	 1448mm
APERTURA COFRE	3381 GMCCA	Spark GT (Gen-1) 2009-2015	L4 Cil. 1.0 L	96875089	CP4	 1528mm

CHEVROLET - SUBURBAN

CONJUNTO SELECTOR CAMBIOS	3430 GMSCC	Suburban Traccion 4x4 2004-2006 T/Automática	5.3 L 5.7 L 6.0 L 8.1 L	88967320	SC59	 3531mm
	3382 GMSCC	Suburban 1999-2007 T/Automática	0	12477640	SC59	 3509mm
	3439 GMSCC	Suburban Traccion 2R 1999-2007 T/Automática	0	12477639	SC59	 3332mm
	3442 GMSCC	Suburban 2001-2006 T/Automática	0	19167308	SC59	 3241mm
	3437 GMSCC	Suburban 1500, 2500, LS, LT, Z71 2000-2006 T/Automática	5.3 L 6.0 L 8.1 L	88967321	SC59	 3332mm
SELECTOR CAMBIOS	3465 GMSCC	Suburban 2007-2012 T/Automática	V8 Cil. 5.3 L	20787606	SC60 Tramo Inferior	 1620mm
	3467 GMSCC	Suburban 2007-2012 T/Automática	V8 Cil. 5.3 L	20787610	SC60 Tramo Inferior	 1446mm
	3466 GMSCC	Suburban Traccion 2R 2007-2009 T/Automática	V8 Cil. 5.3 L	20787607	SC60 Tramo Inferior	 1397mm
	3715 GMSCC	Suburban 1/2, 3/4 - Ton Traccion 2R 2007 - 2012 T/Automática	0	19177020	SC77	 3280mm
	3440 GMSCC	Suburban 1999-2007 T/Automática	V8 Cil. 5.3 L	25836132	SC57 Tramo Inferior	 1623mm
	3438 GMSCC	Suburban Traccion 2R 1999-2007 T/Automática	V8 Cil. 5.3 L	15118283	SC57 Tramo Inferior	 1446mm

Encino 3287 col. del Fresno Guadalajara Jal.







Tel. Multilínea (33) 3811 6917 - Servi-Cliente Cel. 33 1992 6768 - Guadalajara, Jalisco
Correo: ventas@flexcontrol.com.mx - www.flexcontrol.com.mx - www.cablesnavcar.com

Automóvil - Suv - Van - Pickup - Camiones Pesados - Ligeros

IMPORTANTE. Evite devoluciones o reclamos. Identifique previamente: marca, modelo y año del vehículo. En caso de duda, **CONSULTE** a su asesor.

NUESTRA MISIÓN... Ser su aliado en el desarrollo y crecimiento de su negocio

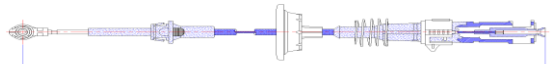
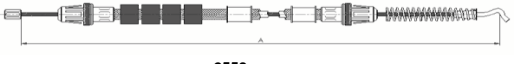
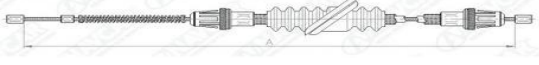
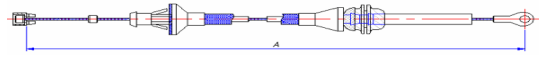
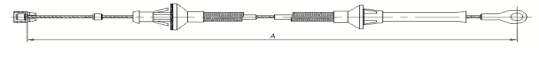
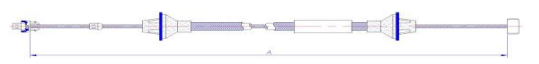
Competimos directamente con los ORIGINALES

LINEA	CODIGO	MODELO	MOTOR	O.E.M	ARMADO	IMAGEN -- LONGITUD
SELECTOR CAMBIOS	3441 GMCS	Suburban 2001-2006 T/Automática	V8 Cil. 5.3 L	15822857	SC57 Tramo Inferior	 1355mm
	3436 GMCS	Suburban Traccion 2R 2000-2006 T/Automática	V8 Cil. 5.3 L	15784586	SC57 Tramo Inferior	 1446mm
	3435 GMCS	Suburban Traccion 2R 1500 LS, 1500 LT, Z71 2000-2006 T/Automática	V8 Cil. 5.3 L	15251896	SC58 Tramo Superior	 1892
	3434 GMCS	Suburban 1500 LS, 1500 LT, Z71 2000-2006 T/Automática	V8 Cil. 5.3 L	15784587	SC57 Tramo Inferior	 1645mm
	4010 GMCS	Suburban 2015... T/Automática	5.3 L	22893848	SC60 Tramo Inferior	 1393mm
	4029 GMCS	Suburban 2015-2018 T/Automática	V8 Cil. 4.3L 6.0L 6.2L	22791727	SC58 Tramo Superior	 1784 mm
FRENO DE MANO	2818 GMCFP	Suburban 2000 - 2004	V8 Cil. 5.3 L	15087072	FP263	 2558mm
	2685 GMCFP	Suburban 2500 1995-2002	V8 Cil. 5.3 L	15043361 15706385 15720251	FP223 Principal	 1295mm
ACELERADOR	1552 GMCA	Suburban 1982-1986	V6 Cil. 2.8 L	14038644	AC3	 967mm
	1520 GMCA	Suburban Motor 350K - 454N 1988 - 1990	V8 Cil. 5.7 L	15551476	AC1	 730mm
	3445 GMCAC	Suburban 1999-2000	V8 Cil. 5.3 L	15712337 22542664 15040848	AC247	 960mm
	3444 GMCAC	Suburban 1996-2000	0	15735412	AC116	 1221mm
SOBREMARCHA	1622 GMSB	Suburban THM700-4R 1983 - 1984	0	25515600	SB2	 1185mm







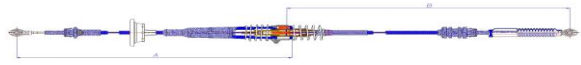
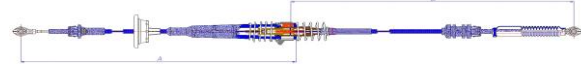
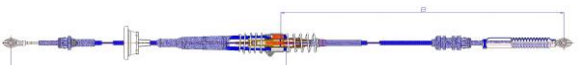
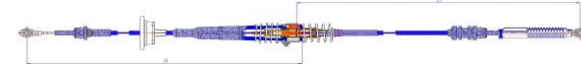
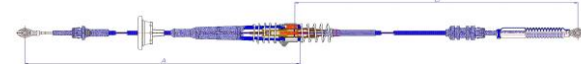
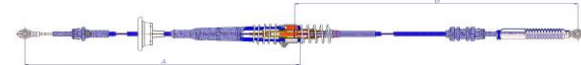

CHEVROLET - TAHOE

Automóvil - Suv - Van - Pickup - Camiones Pesados - Ligeros

¡IMPORTANTE. Evite devoluciones o reclamos. Identifique previamente: marca, modelo y año del vehículo. En caso de duda, **CONSULTE** a su asesor.

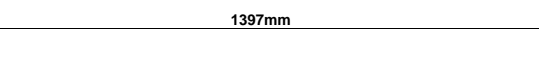
NUESTRA MISIÓN... Ser su aliado en el desarrollo y crecimiento de su negocio

Competimos directamente con los ORIGINALES



LINEA	CODIGO	MODELO	MOTOR	O.E.M	ARMADO	IMAGEN -- LONGITUD
CONJUNTO SELECTOR CAMBIOS	3430 GMSCS	Tahoe 2000-2006 T/Automática	V8 Cil. 4.8 L 5.3 L	88967320	SC59	 3531mm
	3382 GMSCS	Tahoe 1999-2007 T/Automática	0	12477640	SC59	 3509mm
	3439 GMSCS	Tahoe Traccion 2R 1999-2007 T/Automática	0	12477639	SC59	 3332mm
	3442 GMSCS	Tahoe 2001-2006 T/Automática	0	19167308	SC59	 3241mm
	3437 GMSCS	Tahoe Traccion 2R 2000-2006 T/Automática	V8 Cil. 4.8 L 5.3 L	88967321	SC59	 3332mm
	4306 GMSCS	Tahoe 2007-2014 T/Automática	V8 Cil. 6.8 L	0	SC77	 3391mm
SELECTOR CAMBIOS	3465 GMSCS	Tahoe 2007-2012 T/Automática	V8 Cil. 5.3 L	20787606	SC60 Tramo Inferior	 1620mm
	2914 GMSCS	Tahoe Traccion 2R 1995-2002 T/Automática	V6 Cil. 4.3 L	15037353	SC46	 2874mm
	3466 GMSCS	Tahoe Traccion 2R Hybrid 2007-2009 T/Automática	V8 Cil. 5.3 L	20787607	SC60 Tramo Inferior	 1397mm
	3467 GMSCS	Tahoe Traccion 2R Hybrid 2007-2012 T/Automática	V8 Cil. 5.3 L	20787610	SC60 Tramo Inferior	 1446mm
	3484 GMSCS	Tahoe Hybrid, LT 2011-2012 T/Automática	V8 Cil. 5.3 L 6.0 L	20787612	SC60 Tramo Inferior	 1485mm
	3716 GMSCS	Tahoe Traccion 2R Traccion 4x4 2007 - 2012 T/Automática	0	19180564	SC77	 3370mm
	3715 GMSCS	Tahoe Traccion 2R Traccion 4x4 2007 - 2012 T/Automática	0	19177020	SC77	 3280mm
	3440 GMSCS	Tahoe 1999-2007 T/Automática	V8 Cil. 5.3 L	25836132	SC57 Tramo Inferior	 1623mm

Automóvil - Suv - Van - Pickup - Camiones Pesados - Ligeros

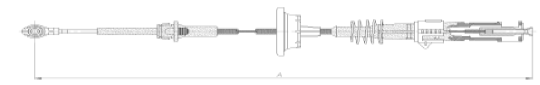
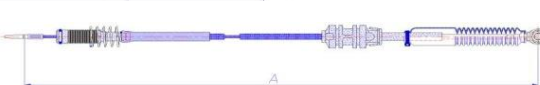
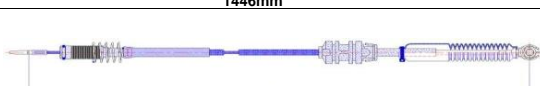
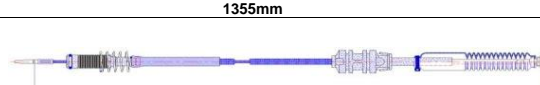

IMPORTANTE. Evite devoluciones o reclamos. Identifique previamente: marca, modelo y año del vehículo. En caso de duda, **CONSULTE** a su asesor.

NUESTRA MISIÓN... Ser su aliado en el desarrollo y crecimiento de su negocio

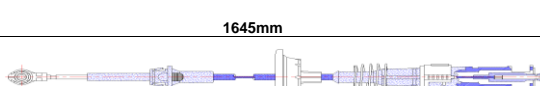
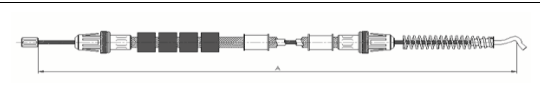
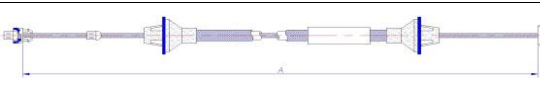
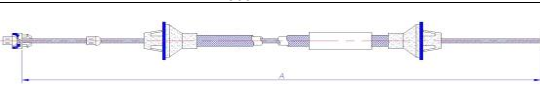
Competimos directamente con los ORIGINALES

LINEA	CODIGO	MODELO	MOTOR	O.E.M	ARMADO	IMAGEN -- LONGITUD
SELECTOR CAMBIOS	3435 GMCSG	Tahoe 1999-2007 T/Automática	V8 Cil. 5.3 L	15251896	SC58 Tramo Superior	 1892mm
	3438 GMCSG	Tahoe Traccion 2R 1999-2007 T/Automática	V8 Cil. 5.3 L	15118283	SC57 Tramo Inferior	 1446mm
	3441 GMCSG	Tahoe 2001-2006 T/Automática	V8 Cil. 5.3 L	15822857	SC57 Tramo Inferior	 1355mm
	3436 GMCSG	Tahoe Traccion 2R 2000-2006 T/Automática	V8 Cil. 5.3 L	15784586	SC57 Tramo Inferior	 1446mm
	3434 GMCSG	Tahoe LS, LT, Z71 2000-2006 T/Automática	V8 Cil. 5.3 L	15784587	SC57 Tramo Inferior	 1645mm
	4029 GMCSG	Tahoe 2015-2018 T/Automática	V8 Cil. 4.3L 6.0L 6.2L	22791727	SC58 Tramo Superior	 1784 mm
FRENO DE MANO	2818 GMCFP	Tahoe 2000 - 2004	V8 Cil. 5.3 L	15087072	FP263	 2558mm
ACELERADOR	3445 GMCAC	Tahoe 1999-2000	V8 Cil. 5.3 L	15712337 22542664 15040848	AC247	 960mm
ACELERADOR	3928 GMCAC	Tahoe 2001-2002	V8 Cil. 5.3 L	15040848	AC247	 956mm

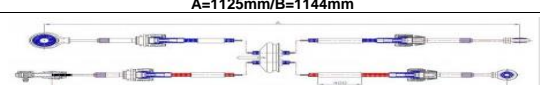
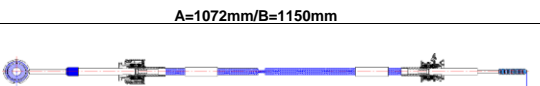
CHEVROLET - TORNADO

KIT SELECTOR Y NEUTRAL CAMBIOS	4068 CHECC	Tornado 2015-2018 T/Standar	1.8L	24585041	CC98	 A=1125mm/B=1144mm
	3406 GMCCC	Tornado Pick-Up 2011-2016 T/Standar	L4 Cil. 1.8 L	93386267 24578500	CC42	 A=1072mm/B=1150mm
NEUTRAL CAMBIOS	4068SM CHECC	Tornado 2015-2018 T/Standar	1.8L	24585041	CC98-S	 B=1144mm
EMBRAGUE	2120 GMCEM	Tornado Pick-Up 2004-2014 T/Standar	1.8L	90446929	EM4	 741mm

CHEVROLET TRAX

Edificio 2287 col. del Fresno Guadalajara Jal.

Tel. Multlínea (33) 3811 6917 - Serv-Cliente Cel. 33 1992 6768 - Guadalajara, Jalisco
Correo: ventas@flexcontrol.com.mx - www.flexcontrol.com.mx - www.cablesnavcar.com

Automóvil - Suv - Van - Pickup - Camiones Pesados - Ligeros



¡IMPORTANTE! Evite devoluciones o reclamos. Identifique previamente: marca, modelo y año del vehículo. En caso de duda, **CONSULTE** a su asesor.

NUESTRA MISIÓN... Ser su aliado en el desarrollo y crecimiento de su negocio

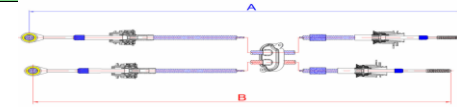
Competimos directamente con los ORIGINALES

LINEA	CODIGO	MODELO	MOTOR	O.E.M	ARMADO	IMAGEN -- LONGITUD
KIT CONTROL Y SELECTOR CAMBIOS	4232 CHECC	Trax	0	55597759	CC119	 A=1113mm/B=1154mm
		2012... T Estandar				

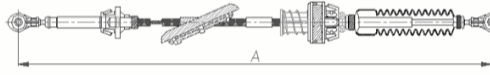

CHEVROLET - TRAILBLAZER

SELECTOR CAMBIOS	3402 GMCSC	Trailblazer 1995-1997 T/Automática	V6 Cil. 4.3 L	15721261	SC27 Palanca al volante	 2576mm
	3761 GMCSC	Trailblazer 4L70E, 4L60E, EXT 2002-2009 T/Automática	V6 Cil. 4.3 L	15785087 10357836 15079394 15101412	SC79	 1886mm
ACELERADOR	3443 GMCAC	Trail Blazer Traccion 2R Traccion 4x4 1996 - 1997	V6 Cil. 4.1 L	15733071	AC116	 1051mm

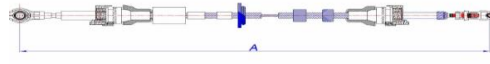
CHEVROLET - TRAVERSE

SELECTOR CAMBIOS	4229 GMCSC	Traverse 2009-2017	V6 Cil. 3.6 L	23256076	SC137	 1051mm
------------------	---------------	-----------------------	------------------	----------	-------	--

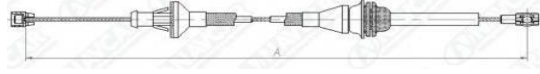

CHEVROLET - UNIVERSAL

ACELERADOR UNIV.	1829 GMCAC	Chevrolet Camioneta 1973 - 1974	V6 Cil. V8 Cil.	3972679	AC125	 548mm
	1828 GMCAC	Chevrolet Camioneta 1970 - 1972	V6 Cil. V8 Cil.	3949068	AC125	 568mm

CHEVROLET - VENTURE

SELECTOR CAMBIOS	3814 GMCSC	Venture 1997-2009 T/Automática	V6 Cil. 4.3 L	103400403 12565602 15299671	SC70	 1558mm
------------------	---------------	--------------------------------------	------------------	-----------------------------------	------	--

CHEVROLET - ZAFIRA

FRENO DE MANO	3948 CHEFP	Zafira 2005-2011	1.6L 2.0L	13157064 522036 522053 522067	FP402 Traseros Derecho/Izquierdo	 A=1460mm/B=1460mm
	3953 CHEFP	Zafira- B 2005-2011	1.6L 2.0L	9127937	FP405 Principal	 320mm

CHRYSLER

CHRYSLER - 200

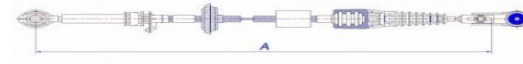
SELECTOR CAMBIOS	4198 CHRSC	200 2011-2014 T/Automática	3.6L	FL3Z-7E395-D	SC130	 1433mm
------------------	---------------	----------------------------------	------	--------------	-------	--

Encino 1287 col. del Fresno Guadalajara Jal.

Tel: Multilínea (33) 3811 6917 - Serv. Cliente Cel: 33 1992 6768 - Guadalajara, Jalisco









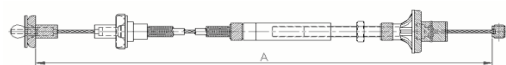

Correo: ventas@flexcontrol.com.mx - www.flexcontrol.com.mx - www.cablesnavcar.com

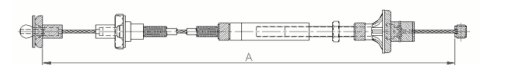
Automóvil - Suv - Van - Pickup - Camiones Pesados - Ligeros

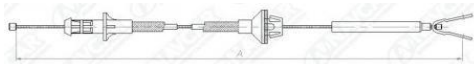
IMPORTANTE. Evite devoluciones o reclamos. Identifique previamente: marca, modelo y año del vehículo. En caso de duda, **CONSULTE** a su asesor.

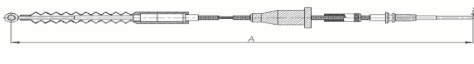
NUESTRA MISIÓN... Ser su aliado en el desarrollo y crecimiento de su negocio

Competimos directamente con los ORIGINALES





LINEA	CODIGO	MODELO	MOTOR	O.E.M	ARMADO	IMAGEN -- LONGITUD
CHRYSLER - 300						
EMBRAGUE	3808 CHREM	300 Tracción 4R tracción trasera VVT 2012	V8 Cil. 3.6 L 5.7 L	04593333 04593103	EM112	 760mm
ACELERADOR	3810 CHRAC	300 1994-2002	V6 Cil. 3.5 L	52079351 53031504AB 53031504	AC269	 1191mm
CHRYSLER - CIRRUS						
SELECTOR CAMBIOS	4224 CHRSC	Cirrus 2000 T/Automático	2.0 L	5274750AF	SC134	 1436mm
EMBRAGUE	3808 CHREM	Cirrus 1995-2000	V8 Cil. 3.6 L 5.7 L	04593333 04593103	EM112	 760mm
CHRYSLER - IMPERIAL						
SELECTOR CAMBIOS	2127 CHRSC	Imperial 1991 - 1995 T/Automática	L4 Cil. 2.5 L V6 Cil. 3.0 L	4543046 4543047	SC25	 892mm
CHRYSLER - K-4						
ACELERADOR	2219 CHRAC	K Turbo 1984-1986	L4 Cil. 2.2 L 2.5 L	4306187	AC175	 1306mm
CHRYSLER - LANDAU						
SELECTOR CAMBIOS (Selector)	3142 CHRSC	Landau 1990-1994 T/Estándar	L4 Cil. 2.5 L V6 Cil. 3.0 L	4446858 4504340	SC53	 1398mm
CHRYSLER - LEBARON						
SELECTOR CAMBIOS	2117 CHRSC	Le Baron 1991-1994 T/Automática	L4 Cil. 2.2 L	4543042	SC23	 1422mm
	2634 CHRSC	Le Baron 1986-1990 T/Automática	L4 Cil. 2.2 L 2.5 L	4377303	SC24 Palanca al Piso	 1422mm
	3143 DODSC	Le Baron 1984-1987 T/Standar	L4 Cil. 2.2 L 2.6 L	4419827	SC54	 1262mm
	2128 CHRSC	Le Baron 1983 T/Automática	0	4269896 4377317	SC26	 889mm
	3142 CHRSC	Le Baron LE, GTC 1990-1994 T/Standar	L4 Cil. 2.5 L V6 Cil. 3.0 L	4446858 4504340	SC53	 1398mm

Automóvil - Suv - Van - Pickup - Camiones Pesados - Ligeros

IMPORTANTE. Evite devoluciones o reclamos. Identifique previamente: marca, modelo y año del vehículo. En caso de duda, **CONSULTE** a su asesor.

NUESTRA MISIÓN... Ser su aliado en el desarrollo y crecimiento de su negocio

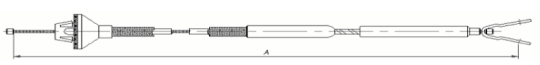
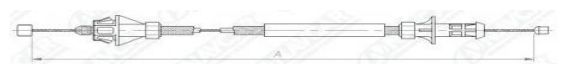

Competimos directamente con los ORIGINALES

LINEA	CODIGO	MODELO	MOTOR	O.E.M	ARMADO	IMAGEN -- LONGITUD
SELECTOR CAMBIOS	2121 CHRSC	Le Baron 1984 - 1989 T/Automática	L4 Cil. 2.2 L 2.5 L	4377302 4593381AB	SC24	 1496mm
CONTROL CAMBIOS (Transversal)	3144 DODSC	Le Baron 1983-1989 T/Standar	L4 Cil. 2.2 L 2.6 L	4419831 4269853 4412669	SC54 (Largo)	 1195mm
EMBRAGUE	1721 DODE	Le Baron 5 Velocidades 1987 - 1987	L4 Cil. 2.2 L	4377769	EM76	 1050mm
ACCELERADOR	1566 DODA	Le Baron 1978 -1983	V6 Cil. 3.7 L	4027354	AC77	 620mm
	2110 CHRAC	Le Baron Turbo 1989 - 1992	L4 Cil. 2.2 L	4300844	AC142	 1345mm
	2178 CHRAC	Le Baron 1990	L4 Cil. 2.5 L	5277832	AC142	 1113mm

CHRYSLER - MINI RAM

ACCELERADOR	2075 CHRAC	Mini Ram 1989	V6 Cil. 3.0 L	4459135	AC142	 948mm
-------------	----------------------	------------------	------------------	---------	-------	---

CHRYSLER - NEW YORKER

SELECTOR CAMBIOS	2128 CHRSC	New Yorker 1983 T/Automática	0	4269896, 4377317	SC26	 889mm
SELECTOR CAMBIOS	2127 CHRSC	New Yorker 1991 - 1995 T/Automática	L4 Cil. 2.5 L V6 Cil. 3.0 L	4543046 4543047	SC25	 892mm
ACCELERADOR	1738 CHRAC	New Yorker 1978 - 1981	V8 Cil. 5.2 L	3769123	AC77	 580mm

CHRYSLER - PACIFICA

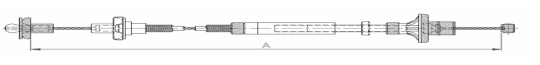
SELECTOR CAMBIOS	2121 CHRSC	Pacifica 1984 - 1989 T/Automática	L4 Cil. 2.2 L 2.5 L	4377302 4593381AB	SC24	 1496mm
EMBRAGUE	3808 CHREM	Pacifica Traccion 4R Traccion Delantera 2004	V8 Cil. 3.6 L 5.7 L	04593333 04593103	EM112	 760mm

CHRYSLER - PT CRUISER

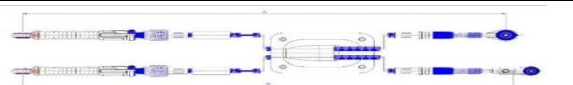



	3398 DODCC	PT Cruiser 2000-2006 T/Standar	L4 Cil. 2.4 L	4641135	CC40	 A=1222mm/B=1222mm
--	----------------------	--------------------------------------	------------------	---------	------	---

Automóvil - Suv - Van - Pickup - Camiones Pesados - Ligeros

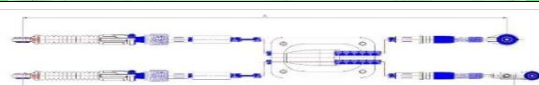
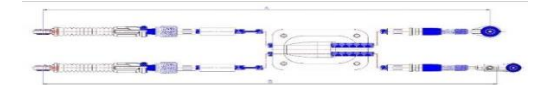

IMPORTANTE. Evite devoluciones o reclamos. Identifique previamente: marca, modelo y año del vehículo. En caso de duda, **CONSULTE** a su asesor.

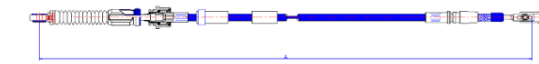
NUESTRA MISIÓN... Ser su aliado en el desarrollo y crecimiento de su negocio

Competimos directamente con los ORIGINALES

LINEA	CODIGO	MODELO	MOTOR	O.E.M	ARMADO	IMAGEN -- LONGITUD
KIT CONTROL Y SELECTOR CAMBIOS	3821 CHRCC	PT Cruiser 2001-2009 T/Standar	L4 Cil. 2.4 L	04668268AC	CC41	 A=1227mm/B=1250mm
	3816 CHRCC	PT Cruiser GT 2003-2009 T/Standar	L4 Cil. 2.4 L	04668844AD 04668844AA 04668844AB 04668844AC	CC41	 A=1273mm/B=1375mm
SELECTOR CAMBIOS	4224 CHRSC	PT Crusier 2000-2005 T/Automática	2.0L	5274750AF	SC134	 1416mm
CONTROL CAMBIOS (Transversal)	3821CM CHRCC	PT Cruiser 2001-2009 T/Standar	L4 Cil. 2.4 L	04668268AC	CC41-C	 B=1250mm
SELECTOR CAMBIOS (Selector)	3821SM CHRCC	PT Cruiser 2001-2009 T/Standar	L4 Cil. 2.4 L	04668268AC	CC41-S	 A=1227mm
FRENO DE MANO	3731 CHRFP	PT Cruiser Classic, Couture Edition, Limited, 2 2003 - 2010	L4 Cil. 2.4 L	5273965AF	FP363 Trasero Izquierdo	 1750mm

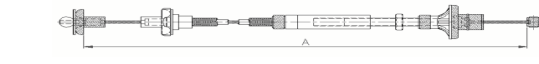
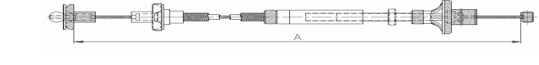
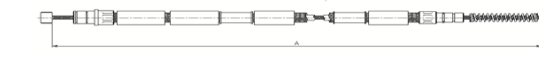
CHRYSLER - SEBRING

SELECTOR CAMBIOS	2752 AMCSC	Sebring 2002 T/Automática	V6 Cil. 2.4 L 2.7 L	52104095	SC29	 1098mm
EMBRAGUE	3808 CHREM	Sebring 1997-1998	V8 Cil. 3.6 L 5.7 L	04593333 04593103	EM112	 760mm
	3809 CHREM	Sebring LX, LX Plus, LXI, Limited GTC 2002-2004	V6 Cil. 2.4 L 2.7 L 3.0 L	04578930AA	EM112	 778mm
FRENO DE MANO	2846 DODFP	Sebring 2001-2004	V6 Cil. 3.0 L	0	FP286 Trasero Derecho	 1771mm
	3171 DODFP	Sebring Coupe 2001-2005	V6 Cil. 3.0 L	0	FP286 Trasero Derecho	 1797mm
SOBREMARCHA	3712 CHR5B	Sebring 2009	V6 Cil. 3.5 L	52104284AB	SB36	 2003mm

CHRYSLER - SPIRIT

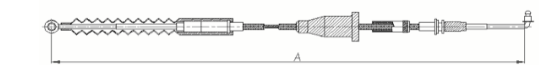

	2117 CHRSC	Spirit 1991-1994 T/Automática	L4 Cil. 2.2 L	4543042	SC23	 1422mm
--	----------------------	-------------------------------------	------------------	---------	------	--

Automóvil - Suv - Van - Pickup - Camiones Pesados - Ligeros

¡IMPORTANTE. Evite devoluciones o reclamos. Identifique previamente: marca, modelo y año del vehículo. En caso de duda, **CONSULTE** a su asesor.

NUESTRA MISIÓN... Ser su aliado en el desarrollo y crecimiento de su negocio

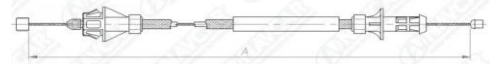

Competimos directamente con los ORIGINALES

LINEA	CODIGO	MODELO	MOTOR	O.E.M	ARMADO	IMAGEN -- LONGITUD
SELECTOR CAMBIOS	2127 CHRSC	Spirit 1991 - 1995 T/Automática	L4 Cil. 2.5 L V6 Cil. 3.0 L	4543046 4543047	SC25	 892mm
	3142 CHRSC	Spirit 1990-1994 T/Estándar	L4 Cil. 2.5 L V6 Cil. 3.0 L	4446858 4504340	SC53	 1398mm
	2178 CHRAC	Spirit 1990-1994	0	5277832	AC142	 1113mm

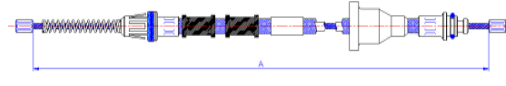
CHRYSLER - STREET CRUISER

FRENO DE MANO	3731 CHRFP	Tourin GT 2003 - 2010	L4 Cil. 2.4 L	5273965AF	FP363 Trasero Izquierdo	 1750mm
---------------	----------------------	-----------------------------	------------------	-----------	-------------------------------	--

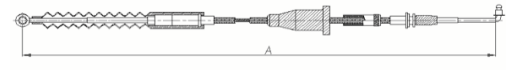
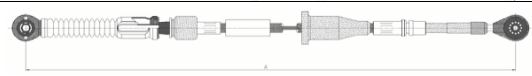

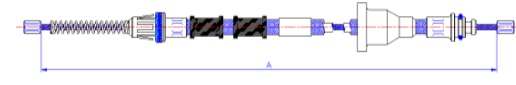

CHRYSLER - SUNDANCE

SELECTOR CAMBIOS	2117 CHRSC	Sundance 1991 - 1995 T/Automática	L4 Cil. 2.2 L	4543042	SC23	 1422mm
	3142 CHRSC	Sundance 1990-1994 T/Standar	L4 Cil. 2.5 L V6 Cil. 3.0 L	4446858 4504340	SC53	 1398mm
	3143 DODSC	Sundance 1984-1987 T/Standar	0	4419827	SC54	 1295mm

CHRYSLER - TOURIN

FRENO DE MANO	3731 CHRFP	Tourin 2003 - 2010	L4 Cil. 2.4 L	5273965AF	FP363 Trasero Izquierdo	 1750mm
---------------	----------------------	-----------------------	------------------	-----------	-------------------------------	--

CHRYSLER - TOWN & COUNTRY

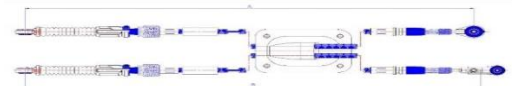
SELECTOR CAMBIOS	4156 CHRSC	Town Contry 1997-2000 T/Automática	V6 3.0L, 3.3L	4670122	SC122	 1135mm
SELECTOR CAMBIOS	4213 CHRSC	Town Contry 2012... T/Automática	3.5L	680801213AE	SC133	 1255mm
CONTROL CAMBIOS (Transversal)	3144 DODSC	Town Country 1983-1989 T/Standar	L4 Cil. 2.2 L 2.6 L	4419831 4269853 4412669	SC54	 1195mm
SELECTOR CAMBIOS (Selector)	3143 DODSC	Town country 1984-1987 T/Standar	0	4419827	SC54	 1262mm
KIT CONTROL Y SELECTOR CAMBIOS	3821 CHRCC	Town Country 2001-2009 T/Standar	3.3 L 3.8 L 4.0 L	04668268AC	CC41	 A=1227mm/B=1250mm

Encino 1287 col. del Fresno Guadalajara Jal.



Tel: Multilínea (33) 3811 6917 - Serv. Cliente Cel: 33 1992 6768 - Guadalajara, Jalisco
Correo: ventas@flexcontrol.com.mx - www.flexcontrol.com.mx - www.cablesnavcar.com

Automóvil - Suv - Van - Pickup - Camiones Pesados - Ligeros



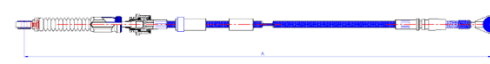
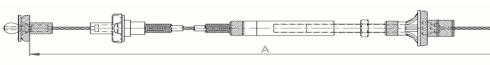
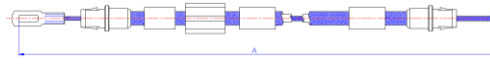
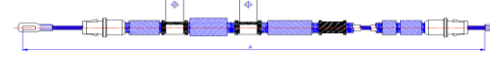

IMPORTANTE. Evite devoluciones o reclamos. Identifique previamente: marca, modelo y año del vehículo. En caso de duda, **CONSULTE** a su asesor.

NUESTRA MISIÓN... Ser su aliado en el desarrollo y crecimiento de su negocio

Competimos directamente con los ORIGINALES

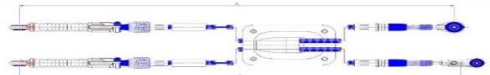
LINEA	CODIGO	MODELO	MOTOR	O.E.M	ARMADO	IMAGEN -- LONGITUD
CONTROL CAMBIOS (Transversal)	3821CM CHRC	Town Country 2001-2009 T/Standar	3.3 L 3.8 L 4.0 L	04668268AC	CC41-C	 B=1250mm
SELECTOR CAMBIOS (Selector)	3821SM CHRC	Town Country 2001-2009 T/Standar	3.3 L 3.8 L 4.0 L	04668268AC	CC41-S	 A=1227mm
EMBRAGUE	3808 CHREM	Town Country SMP 2002	V8 Cil. 3.6 L 5.7 L	04593333 04593103	EM112	 760mm
FRENO DE MANO	3732 CHRF	Town Country Van 2012 - 2014	V6 Cil. 3.6 L	4779806AC	FP362 Trasero Izquierdo	 1346mm
	3725 CHRF	Town y Country Van 2012 - 2014	V6 Cil. 3.6 L	4779807AC	FP358 Trasero Derecho	 2630mm
ACELERADOR	3811 CHRC	Town - Country 4velocidades 1994-1995	V6 Cil. 3.8 L	4300850	AC174	 1277mm

CHRYSLER - VOYAGER

KIT CONTROL Y SELECTOR CAMBIOS	3821 CHRC	Voyager 2001-2009 T/Estándar	3.3 L 3.8 L	04668268AC	CC41	 A=1227mm/B=1250mm
CONTROL CAMBIOS (Transversal)	3821CM CHRC	Voyager 2001-2009 T/Estándar	3.3 L 3.8 L	04668268AC	CC41-C	 B=1250mm
SELECTOR CAMBIOS (Selector)	3821SM CHRC	Voyager 2001-2009 T/Estándar	3.3 L 3.8 L	04668268AC	CC41-S	 A=1227mm
SELECTOR CAMBIOS (Selector)	3143 DODSC	Voyager 1984-1987 T/Estándar	0	4419827	SC54	 1262mm
ACELERADOR	2215 CHRC	Voyager 1990-1993	0	0	AC174	 1263mm

DAEWOO

DAEWOO - RACER

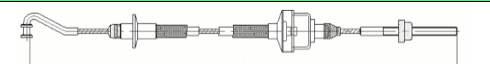
EMBRAGUE	925 DAEE	Racer 1993...	0	90209335	EM162	 811mm
----------	-------------	------------------	---	----------	-------	---

DAEWOO - TICO

Automóvil - Suv - Van - Pickup - Camiones Pesados - Ligeros

IMPORTANTE. Evite devoluciones o reclamos. Identifique previamente: marca, modelo y año del vehículo. En caso de duda, **CONSULTE** a su asesor.





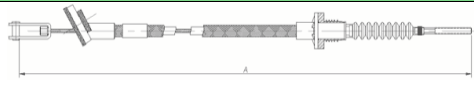



NUESTRA MISIÓN... Ser su aliado en el desarrollo y crecimiento de su negocio

Competimos directamente con los ORIGINALES

LINEA	CODIGO	MODELO	MOTOR	O.E.M	ARMADO	IMAGEN -- LONGITUD
EMBRAGUE	1137 DAEE	Tico 1996...	0	23710A78B10	EM12	 715mm

DFSK

VAN CARGA

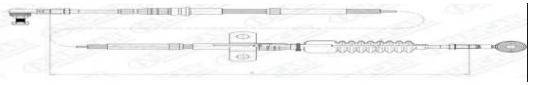
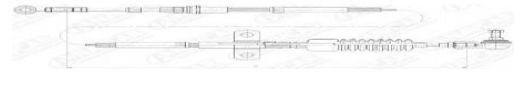

CONTROL CAMBIOS (Transversal)	3937 DFMCC	DFSK van carga MPV T/Standar	1300cc	1703300-02	CC37	 735mm
SELECTOR CAMBIOS (Selector)	3187 DFMSC	DFSK Van Carga MPV T/Standar	1300cc	1703300-01	CC37	 732mm
CONTROL CAMBIOS (Transversal)	3043 DFMCC	DFM Van Carga MPV 1051 cc	0	1703200-01	SC38	 907mm
SELECTOR CAMBIOS (Selector)	3045 DFMSC	DFM Van Carga MPV 1051 cc	0	1703300-01	CC21	 894mm
EMBRAGUE	3042 DFMEM	DFSK Van Carga MPV	1300cc	1602110-01	EM66	 1757mm
VELOCIMETRO	3940 DFMVZ	DFM VanCarga MPV 1300 CC	0	13503397225	VZ103	 2648mm
ACELERADOR	3041 DFMAC	DFSK Van Carga MPV	1300cc	1108110-01	AC229	 1872mm
ACELERADOR	3040 DFMAC	DFM Van Carga MPV 1051 cc	0	1108110-01	AC212	 1815mm

DFM - DONG FENG

CONTROL CAMBIOS (Transversal)	3935 DONCC	Dong Feng Cummins IVZ Carrosería ONIX 860 2015...	3.8L	0	CC54	 2152mm
SELECTOR CAMBIOS (Selector)	3936 DONSC	Dong Feng Cummins IVZ Carrosería ONIX 860 2015...	3.8L	0	SC41	 2153mm

DODGE

DODGE - 600







SELECTOR CAMBIOS	2634 CHRSC	600 1986-1990 T/Automática	L4 Cil. 2.2 L 2.5 L	4377303	SC24 Palanca al Piso	 1422mm
	2128 CHRSC	600 1983 T/Automática	0	4269896, 4377317	SC26	 889mm

Automóvil - Suv - Van - Pickup - Camiones Pesados - Ligeros

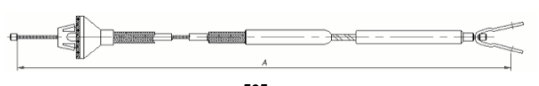
IMPORTANTE. Evite devoluciones o reclamos. Identifique previamente: marca, modelo y año del vehículo. En caso de duda, **CONSULTE** a su asesor.

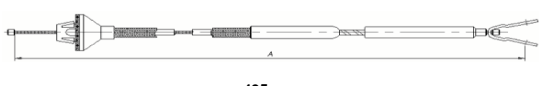
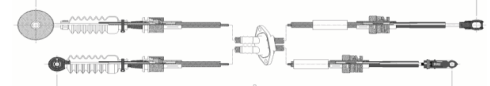
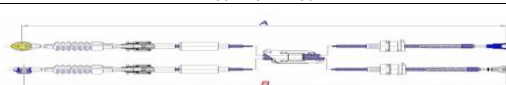
NUESTRA MISIÓN... Ser su aliado en el desarrollo y crecimiento de su negocio

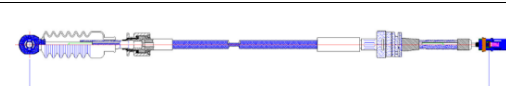
Competimos directamente con los ORIGINALES

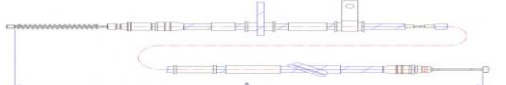
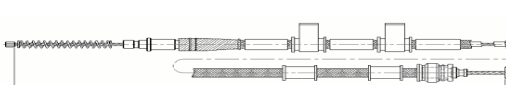
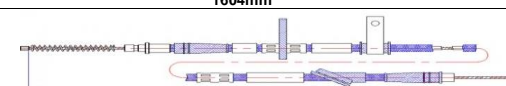



LINEA	CODIGO	MODELO	MOTOR	O.E.M	ARMADO	IMAGEN -- LONGITUD												
CONTROL CAMBIOS (Transversal)	3144 DODSC	600 1983-1989 T/Estándar	L4 Cil. 2.2 L 2.6 L	4419831 4269853 4412669	SC54	 1195mm												
DODGE - ASPEN																		
ACELERADOR	1567 DODA	Aspen 1980	V8 Cil. 5.2 L	4027355	AC77	 505mm												
							1566 DODA	Aspen 1976 - 1978	V6 Cil. 3.7 L	4027354	AC77	 620mm						
													1568 DODA	Aspen 1976 - 1980	V8 Cil. 5.2 L	4027358	AC77	 495mm
DODGE - ATTITUDE																		
KIT CONTROL Y SELECTOR CAMBIOS	2966 HYUCC	Attitude 2005-2011 T/Standar	L4 Cil. 1.6 L	437941G100	CC34	 A=1133mm/B=1256mm												
KIT CONTROL Y SELECTOR CAMBIOS	4239 DODCC	Attitude 2014 T/Estándar	L3 Cil 1.2L	2460A112	CC118	 A=1174mm/B=1114mm												
CONTROL CAMBIOS (Transversal)	2966CM HYUCC	Attitude 2005-2011 T/Standar	L4 Cil. 1.6 L	437941G100	CC34-C	 A=1133mm												
SELECTOR CAMBIOS (Selector)	2966SM HYUCC	Attitude 2005-2011 T/Standar	L4 Cil. 1.6 L	437941G100	CC34-S	 B=1256mm												
EMBRAGUE	3963 MITEM	Attitude 2014-2017	L4 Cil. 1.6 L	2342A019	EM145	 950mm												
FRENO DE MANO	2440 HYUFP	Attitude 1995 - 2000	L4 Cil. 1.4 L 1.5 L 1.6 L	5976022110	FP194 Trasero Izquierdo	 1482mm												
							2643 HYUFP	Attitude 2006...	L4 Cil. 1.4 L 1.5 L 1.6 L	597601G000	FP203 Trasero Izquierdo	 1604mm						
													2439 HYUFP	Attitude 1995 - 2000	L4 Cil. 1.4 L 1.5 L 1.6 L	5977022110	FP194 Trasero Derecho	 1482mm

Automóvil - Suv - Van - Pickup - Camiones Pesados - Ligeros

IMPORTANTE. Evite devoluciones o reclamos. Identifique previamente: marca, modelo y año del vehículo. En caso de duda, **CONSULTE** a su asesor.

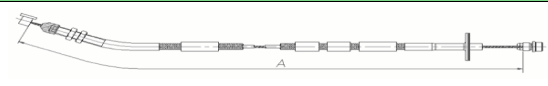
NUESTRA MISIÓN... Ser su aliado en el desarrollo y crecimiento de su negocio

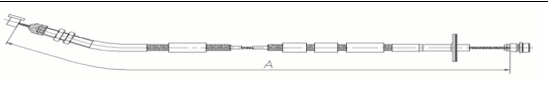
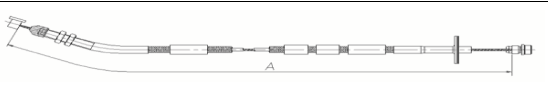
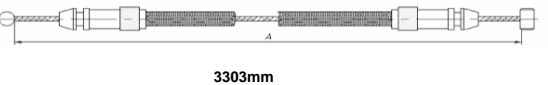
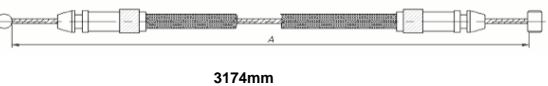
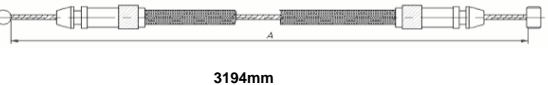
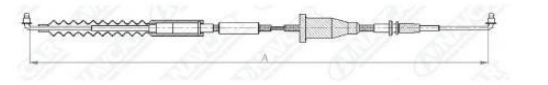
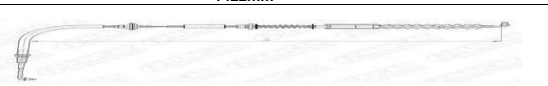
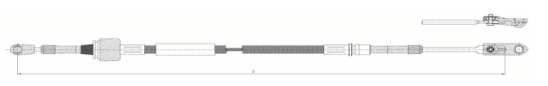
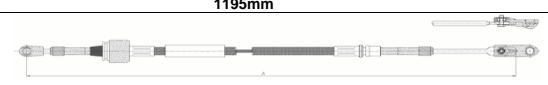
Competimos directamente con los ORIGINALES

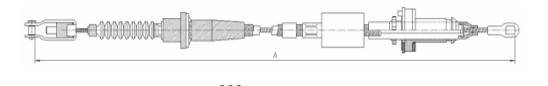



LINEA	CODIGO	MODELO	MOTOR	O.E.M	ARMADO	IMAGEN -- LONGITUD
ACELERADOR	2448 HYUAC	Attitude 1995 - 2000	L4 Cil. 1.5 L 1.6 L	3279022002	AC210	 1562mm
	2641 HYUAC	Attitude 2006...	L4 Cil. 1.5 L 1.6 L	327901G000	AC211	 1129mm
	3499 HYUAC	Attitude GLS 2000 - 2006	L4 Cil. 1.5 L 1.6 L	3279025105	AC210	 1454mm
	2449 HYUAC	Attitude, 2003 - 2006	L4 Cil. 1.5 L 1.6 L	3279025050	AC210	 1545mm
APERTURA CAJUELA	2597 HYUAB	Attitude 2006...	L4 Cil. 1.6 L	0	AB2	 3303mm
	1945 HYUAB	Attitude 1995...	L4 Cil. 1.6 L	8128022201	AB2	 3174mm
	1944 HYUAB	Attitude 1995...	L4 Cil. 1.6 L	8128022001	AB2	 3194mm
DODGE - ARIES						
SELECTOR CAMBIOS	2634 CHRSC	Aries 1986-1990 T/Automática	L4 Cil. 2.2 L 2.5 L	4377303	SC24 Palanca al Piso	 1422mm
	2128 CHRSC	Aries 1983 T/Automática	L4 Cil. 2.6 L	4269896, 4377317	SC26	 889mm
CONTROL CAMBIOS (Transversal)	3144 DODSC	Aries 1983-1989 T/Estándar	L4 Cil. 2.2 L 2.6 L	4419831 4269853 4412669	SC54	 1195mm
SELECTOR CAMBIOS (Selector)	3143 DODSC	Aries 1984-1987 T/Standar	0	4419827	SC54	 1295mm
EMBRAGUE	1666 DODE	Aries 1981 - 1983	L4 Cil. 2.6 L	4505533 4505341	EM76	 1085mm
VELOCIMETRO	3421 AMCVZ	Aries 1986-1989	V6 Cil. 3.8 L	4897589AA	VZ45	 2046mm
DODGE - ATOS						
	1801 HYUEM	Atos 2000-2010	L4 Cil. 1.0 L 1.1 L	4151002010	EM79	 820mm

Automóvil - Suv - Van - Pickup - Camiones Pesados - Ligeros

IMPORTANTE. Evite devoluciones o reclamos. Identifique previamente: marca, modelo y año del vehículo. En caso de duda, **CONSULTE** a su asesor.

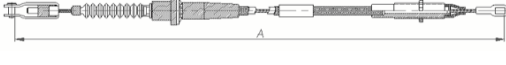
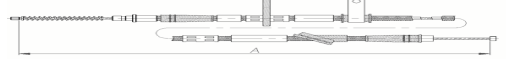
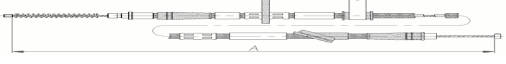
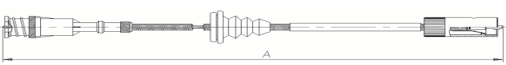
NUESTRA MISIÓN... Ser su aliado en el desarrollo y crecimiento de su negocio

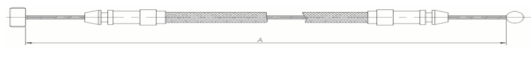

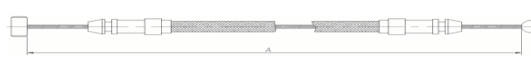

Competimos directamente con los ORIGINALES

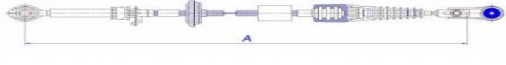
LINEA	CODIGO	MODELO	MOTOR	O.E.M	ARMADO	IMAGEN -- LONGITUD
EMBRAGUE	2523 HYUEM	Atos Prime 2000-2010...	L4 Cil. 1.0 L 1.1 L	4151002010	EM109 Sin Pesa	 820mm
	2295 HYUFP	Atos 2000-2010	L4 Cil. 1.0 L 1.1 L	5976002000	FP152 Trasero Izquierdo	 1498mm
FRENO DE MANO	2294 HYUFP	Atos 2000-2010	L4 Cil. 1.0 L 1.1 L	5977002010	FP152 Trasero Derecho	 1512mm
	2068 HYUVZ	Atos todos	L4 Cil. 1.0 L 1.1 L	9424002000	VZ75	 881mm
ACELERADOR	2045 HYUAC	Atos 2000-2004	L4 Cil. 1.0 L 1.1 L	3279002010	AC140	 665mm
	2345 HYUAC	Atos 2005-2012	L4 Cil. 1.0 L	3279005000	AC169	 1767mm
APERTURA CAJUELA	3401 HYUAB	Atos GL 2008-2010	L4 Cil. 1.0 L 1.1 L	0	CP9	 2680mm
APERTURA COFRE	1998 HYUCA	Atos 2000-2007	L4 Cil. 1.0 L 1.1 L	8119002000	CP9	 1395mm
APERTURA COFRE	3400 HYUCA	Atos 2008-2010	L4 Cil. 1.0 L 1.1 L	0	CP9	 1503mm

DODGE - AVENGER

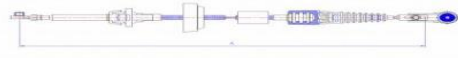
SELECTOR CAMBIOS	4198 CHRSC	Avenger 2007-2014 T/Automática	3.5L	FL3Z-7E395-D	SC130	 1433mm
------------------	----------------------	--------------------------------------	------	--------------	-------	--

DODGE - CARAVAN



SELECTOR CAMBIOS	4156 CHRSC	Caravan 1997-2000 T/Automática	V6 3.0L, 3.3L	4670122	SC122	 1135mm
	2127 CHRSC	Caravan 1991 - 1995 T/Automática	L4 Cil. 2.5 L V6 Cil. 3.0 L	4543046 4543047	SC25	 892mm
SELECTOR CAMBIOS (Selector)	3142 CHRSC	Caravan 1990-1994 T/Standar	L4 Cil. 2.5 L V6 Cil. 3.0 L	4446858 4504340	SC53	 1398mm
CONTROL CAMBIOS (Transversal)	3144 DODSC	Caravan 1983-1989 T/Standar	L4 Cil. 2.2 L 2.6 L	4419831 4269853 4412669	SC54	 1195mm

Automóvil - Suv - Van - Pickup - Camiones Pesados - Ligeros

IMPORTANTE. Evite devoluciones o reclamos. Identifique previamente: marca, modelo y año del vehículo. En caso de duda, **CONSULTE** a su asesor.

NUESTRA MISIÓN... Ser su aliado en el desarrollo y crecimiento de su negocio

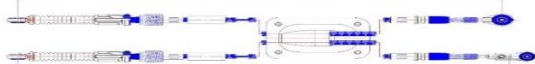

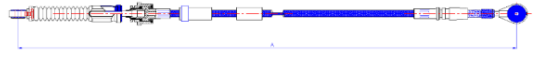
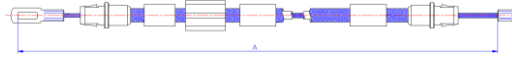
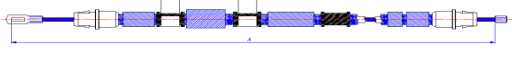
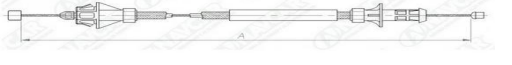

Competimos directamente con los ORIGINALES

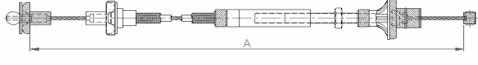
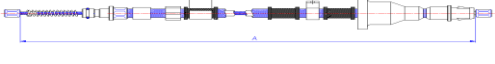
LINEA	CODIGO	MODELO	MOTOR	O.E.M	ARMADO	IMAGEN -- LONGITUD
SELECTOR CAMBIOS (Selector)	3143 DODSC	Caravan 1984-1987 T/Standar	0	4419827	SC54	 1262mm
KIT CONTROL Y SELECTOR CAMBIOS	3821 CHRCC	Caravan 2001-2012 T/Standar	3.0 L 3.3 L 3.6 L	04668268AC	CC41	 A=1227mm / B=1250mm
CONTROL CAMBIOS (Transversal)	3821CM CHRCC	Caravan 2001-2012 T/Standar	3.0 L 3.3 L 3.6 L	04668268AC	CC41-C	 B=1250mm
SELECTOR CAMBIOS (Selector)	3821SM CHRCC	Caravan 2001-2012 T/Standar	3.0 L 3.3 L 3.6 L	04668268AC	CC41-S	 A=1227mm
FRENO DE MANO	3732 CHRFP	Caravan 2012 - 2014	V6 Cil. 3.6 L	4779806AC	FP362 Trasero Izquierdo	 1346mm
	3725 CHRFP	Caravan, 2012 - 2014	V6 Cil. 3.6 L	4779807AC	FP358 Trasero Derecho	 2630mm
ACELERADOR	2075 CHRAC	Caravan 1989	V6 Cil. 3.0 L	4459135	AC142	 948mm

DODGE - CALIBER

EMBRAGUE	3808 CHREM	Caliber 2012	L4 Cil. 2.0 L 2.4 L 2.5 L	04593333 04593103	EM112	 760mm
FRENO DE MANO	3730 DODFP	Caliber 2007 - 2013	L4 Cil. 2.0 L 2.4 L	4877016AB 04877016AC 04877016AA 05105140AB 05105140AC 05105140AD	FP364 Trasero Derecho	 1575mm

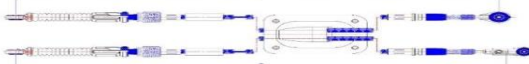
DODGE - CHARGER



CONTROL CAMBIOS (Transversal)	3144 DODSC	Charger 1983-1989 T/Standar	L4 Cil. 2.2 L 2.6 L	4419831 4269853 4412669	SC54	 1195mm
SELECTOR CAMBIOS (Selector)	3143 DODSC	Charger 1984-1987 T/Standar	0	4419827	SC54	 1262mm
KIT CONTROL Y SELECTOR CAMBIOS	3821 CHRCC	Charger 2001-2012 T/Standar	3.0 L 3.3 L 3.6 L	04668268AC	CC41	 A=1227mm/B=1250mm
CONTROL CAMBIOS (Transversal)	3821CM CHRCC	Charger 2001-2012 T/Standar	3.0 L 3.3 L 3.6 L	04668268AC	CC41-C	 B=1250mm

Automóvil - Suv - Van - Pickup - Camiones Pesados - Ligeros

IMPORTANTE. Evite devoluciones o reclamos. Identifique previamente: marca, modelo y año del vehículo. En caso de duda, **CONSULTE** a su asesor.

NUESTRA MISIÓN... Ser su aliado en el desarrollo y crecimiento de su negocio







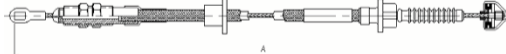

Competimos directamente con los ORIGINALES

LINEA	CODIGO	MODELO	MOTOR	O.E.M	ARMADO	IMAGEN -- LONGITUD
SELECTOR CAMBIOS (Selector)	3821SM CHRSC	Charger 2001-2012 T/Standar	3.0 L 3.3 L 3.6 L	04668268AC	CC41-S	 A=1227mm
EMBRAGUE	1666 DODE	Charger 1983	L4 Cil. 2.6 L	4505533 4505341	EM76	 1085mm

DODGE - COLT

EMBRAGUE	1846 MITEM	Colt 1986 - 1989	L4 Cil. 1.5 L	MB527467	EM51	 1388mm
----------	---------------	---------------------	------------------	----------	------	--

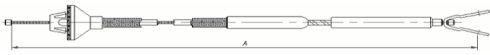
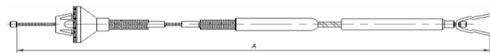
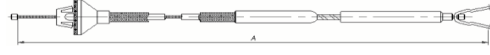
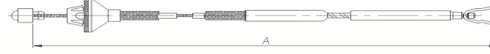
DODGE -D100 -D150 - D200 - D250 - D300 - D350 - D400 - D450

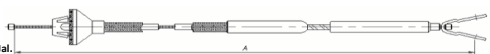

FRENO DE MANO	2946 DODFP	D100 1963 - 1969	V6 Cil. 3.8 L	2511363	FP279	 1073mm
VELOCIMETRO	743 CHRZV	D100 / D300 1975 - 1980	0	4085498	VZ48	 1560mm
	3421 AMCVZ	D100 1986-1989	0	4897589AA	VZ45	 2046mm
ACELERADOR	1584 DODA	D100 / D300 1968 - 1977	V6 Cil. 3.7 L	3820952	AC75	 695mm
	1797 DODAC	D100 / D300	V8 Cil. 5.9 L	4104277	AC77	 665mm
	1790 DODAC	D100 / D300 1977 - 1979	V8 Cil. 5.9 L	4088095	AC75	 620mm
	1792 DODAC	D100 / D300 1978 - 1984	V6 Cil. 3.7 L	2946700	AC77	 685mm
	1800 DODAC	D100 / D150 1984 - 1988	V8 Cil. 5.2 L	4275939	AC77	 720mm
	1724 DODA	D300 / D350	V8 Cil. 5.2 L	4275940	AC77	 695mm
	1808 DODAC	D350 1992 - 1993	V8 Cil. 5.2 L	4710361	AC214	 665mm
	1789 DODAC	D100 / D300 1988 - 1991	V6 Cil. 5.9 L	4405061	AC75	 700mm
	1581 DODA	D100, D150, D200, D250, D300, D350, D400, D450 Todos 1980 - 1987	V8 Cil. 5.2 L 5.9 L	4241224	AC77	 675mm

Automóvil - Suv - Van - Pickup - Camiones Pesados - Ligeros

IMPORTANTE. Evite devoluciones o reclamos. Identifique previamente: marca, modelo y año del vehículo. En caso de duda, **CONSULTE** a su asesor.

NUESTRA MISIÓN... Ser su aliado en el desarrollo y crecimiento de su negocio

Competimos directamente con los ORIGINALES

LINEA	CODIGO	MODELO	MOTOR	O.E.M	ARMADO	IMAGEN -- LONGITUD
	1798 DODAC	D300 1975 - 1985	V8 Cil. 5.2 L	3828366	AC77	 705mm
	2178 CHRA	D150 / D300 1990	V6 Cil. 3.7 L	5277832	AC142	 1113mm
DODGE - D600						
ACELERADOR	1793 DODAC	D600 1975 - 1983	V6 Cil. 3.7 L	3733945	AC77	 810mm
ACELERADOR	1798 DODAC	D600 1975 - 1985	V8 Cil. 5.2 L	3828366	AC77	 705mm
DODGE - DAKOTA						
FRENO DE MANO	3974 DODFP	Dakota 1987-1996	2.2L, 2.5L, 3.9L, 5.2L	4294383	FP279 Trasero Derecho/izquierdo	 854mm
VELOCIMETRO	3421 AMCVZ	Dakota 1986-1989	V6 Cil. 3.8 L	4897589AA	VZ45	 2046mm
SOBREMARCHA	3710 DODSB	Dakota 1997-1999	V6 Cil. 3.9 L 5.2 L V8 Cil. 5.9 L	52104030A	SB36	 1566mm
ACELERADOR	3745 DODAC	Dakota SLT, Sport, R/T Gas 4x4 2002-2003	V8 Cil. 5.9 L	53031556AB	AC266	 1250mm
DODGE - DART K						
CONTROL CAMBIOS (Transversal)	3144 DODSC	Dart k vorale 1986-88 T/Estándar	L4 Cil. 2.2 L 2.6 L	4419831 4269853 4412669	SC54	 1195mm
EMBRAGUE	1655 DODE	Dart K 1982-1983	L4 Cil. 2.2 L	4188656 4369592	EM76	 1050mm
EMBRAGUE	2286 DODEM	Dart K 1984-1986	L4 Cil. 2.4 L	4369591 4377771	EM76	 1090mm
	146 DARA	Dart 1968 - 1975	V6 Cil. 3.3 L	2899335	AC75	 620mm
ACELERADOR	1567 DODA	Dart Super 1976 - 1986	V8 Cil. 5.2 L	4027355	AC77	 505mm

Automóvil - Suv - Van - Pickup - Camiones Pesados - Ligeros



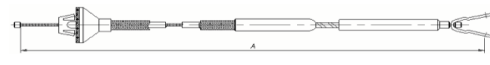
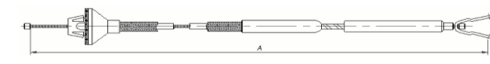

IMPORTANTE. Evite devoluciones o reclamos. Identifique previamente: marca, modelo y año del vehículo. En caso de duda, **CONSULTE** a su asesor.

NUESTRA MISIÓN... Ser su aliado en el desarrollo y crecimiento de su negocio

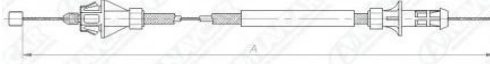

Competimos directamente con los ORIGINALES

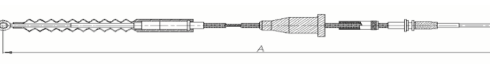
LINEA	CODIGO	MODELO	MOTOR	O.E.M	ARMADO	IMAGEN -- LONGITUD
ACCELERADOR	1566 DODA	Dart 1976 - 1986	V6 Cil. 3.7 L	4027354	AC77	 620mm
	1568 DODA	Dart 1976 - 1978	V8 Cil. 5.2 L	4027358	AC77	 495mm

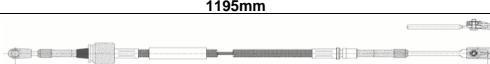
DODGE - DAYTONA

ACCELERADOR	2110 CHRAC	Daytona Turbo 1989	L4 Cil. 2.5 L	4300844	AC142	 1345mm
SELECTOR CAMBIOS	2121 CHRSC	Daytona 1984 - 1989 T/Automática	L4 Cil. 2.2 L 2.5 L	4377302 4593381AB	SC24	 1496mm
	2118 DODSC	Daytona 1991 - 1993 T/Automática	V6 Cil. 2.5 L 3.0 L	4670133	SC23	 1499mm
CONTROL CAMBIOS (Transversal)	3144 DODSC	Daytona 1983-1989 T/Estándar	L4 Cil. 2.2 L 2.6 L	4419831 4269853 4412669	SC54	 1195mm
SELECTOR CAMBIOS (Selector)	3143 DODSC	Daytona 1984-1987 T/Standar	0	4419827	SC54	 1262mm

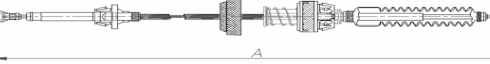
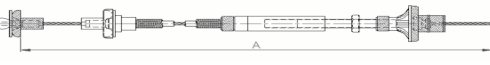
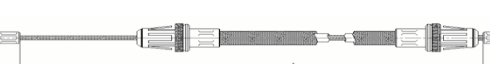
DODGE - DURANGO

SELECTOR CAMBIOS	2752 AMCSC	Durango MPI 2000 T/Automática	V6 Cil. 4.7 L V8 Cil. 5.2 L 5.9 L	52104095	SC29	 1098mm
EMBRAGUE	3808 CHREM	Durango 4x2 - 4x4 2006	L4 Cil. 2.0 L 2.4 L 2.5 L	04593333 04593103	EM112	 760mm
FRENO DE MANO	2845 DODFP	Durango 1999	V6 Cil. 3.9 L 5.2 L 5.9 L	0	FP240 Principal	 1618mm
SOBREMARCHA	3710 DODSB	Durango 1997-1999	V6 Cil. 4.7 L V8 Cil. 5.2 L 5.9 L	52104030A	SB36	 1566mm
ACCELERADOR	3745 DODAC	Durango SXT, Sport, SLT, R/T, Base Gas 1998-2003	V8 Cil. 5.9 L	53031556AB	AC266	 1250mm

DODGE - GRAND CARAVAN

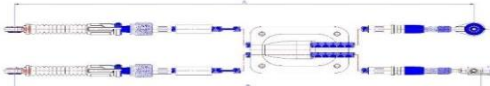





KIT CONTROL Y SELECTOR CAMBIOS	3821 CHRCC	Grand Caravan 2001 T/Standar	3.0 L 3.3 L 3.6 L	04668268AC	CC41	 A=1227mm/B=1250mm
--------------------------------	----------------------	------------------------------------	-------------------------	------------	------	---

Automóvil - Suv - Van - Pickup - Camiones Pesados - Ligeros



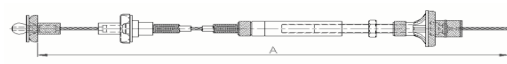

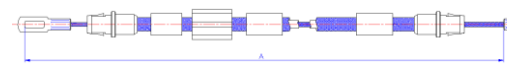
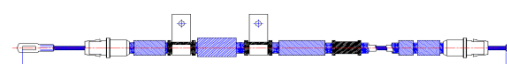

IMPORTANTE. Evite devoluciones o reclamos. Identifique previamente: marca, modelo y año del vehículo. En caso de duda, **CONSULTE** a su asesor.

NUESTRA MISIÓN... Ser su aliado en el desarrollo y crecimiento de su negocio

Competimos directamente con los ORIGINALES

LINEA	CODIGO	MODELO	MOTOR	O.E.M	ARMADO	IMAGEN -- LONGITUD
CONTROL CAMBIOS (Transversal)	3821CM CHRCC	Grand Caravan 2001 T/Standar	3.0 L 3.3 L 3.6 L	04668268AC	CC41-C	 B=1250mm
SELECTOR CAMBIOS (Selector)	3821SM CHRCC	Grand Caravan 2001 T/Standar	3.0 L 3.3 L 3.6 L	04668268AC	CC41-S	 A=1227mm
EMBRAGUE	3808 CHREM	Grand Caravan SMPI, 2002	L4 Cil. 2.0 L 2.4 L 2.5 L	04593333 04593103	EM112	 760mm
	3096 DODEM	Grand Caravan Traccion 2R 1993	V6 Cil. 3.3 L	4511098	EM76	 1050mm
FRENO DE MANO	3732 CHRFP	Gran Caravan 2012 - 2014	V6 Cil. 3.6 L	4779806AC	FP362 Trasero Izquierdo	 1346mm
FRENO DE MANO	3725 CHRFP	Grand Caravan 2012 - 2014	V6 Cil. 3.6 L	4779807AC	FP358 Trasero Derecho	 2630mm
ACELERADOR	3811 CHRAC	Gran Caravan 1994-1995	V6 Cil. 3.8 L 3.3 L	4300850	AC174	 1277mm

DODGE - H-100

KIT CONTROL Y SELECTOR CAMBIOS	1420 HYUC	H100 Diesel 1994... T/Standar	0	4377043254	CC9	 A=1719mm/B=1584mm
	1421 HYUC	H100 Gasolina 1994... T/Standar	0	4377043624	CC9	 A=1616mm/B=1481mm
	3996 HYUCC	H100 Carga Gasolina 2003-2005.	2.4L	4377-04B260	CC9	 A=1702mm/B=1568mm
	3961 HYUCC	H100 Van, Porter II Truck Diesel 2004-2010 T/Estándar	2,5L	43794-4f200	CC79	 A=1736mm/B=1648mm
	3960 HYUCC	H100 Pick-Up Gasolina 2003-2005 T/Standar	2.4L	4377-04B260	CC9	 A=1796mm/B=1660mm
	3997 HYUCC	H100 Pick-Up Diesel 2006-2013. H100 Carga Diesel 2006-2013	2.5 L	43794-4F210	CC87	 A=1825mm/B=1724mm
CONTROL CAMBIOS (Transversal)	3798 HYUCC	H100 Diesel 2006-2013 T/Estándar	L4 Cil. 2.4 L	0	CC59	 1659mm

Encino 1287 col. del Fresno Guadalajara Jal.







Tel. Multlínea (33) 3811 6917 - Serv. Cliente Cel. 33 1992 6768 - Guadalajara, Jalisco
Correo: ventas@flexcontrol.com.mx - www.flexcontrol.com.mx - www.cablesnavcar.com

Automóvil - Suv - Van - Pickup - Camiones Pesados - Ligeros



IMPORTANTE. Evite devoluciones o reclamos. Identifique previamente: marca, modelo y año del vehículo. En caso de duda, **CONSULTE** a su asesor.

NUESTRA MISIÓN... Ser su aliado en el desarrollo y crecimiento de su negocio



Competimos directamente con los ORIGINALES

LINEA	CODIGO	MODELO	MOTOR	O.E.M	ARMADO	IMAGEN -- LONGITUD
SELECTOR CAMBIOS (Selector)	3799 HYUSC	H100 Diesel 2006-2013 T/Standar	L4 Cil. 2.4 L	0	SC78	 1826mm
FRENO DE MANO	4000 HYUFP	H100- VAN 1995-2004	2.5L	59911-43450	FP416 Trasero Izquierdo	 2030mm
FRENO DE MANO	4002 HYUFP	H100- VAN 1995-2004	2.5L	59911-43450	FP414 Trasero Derecho	 2646mm
VELOCIMETRO	1142 HYUVZ	H100 Gasolina 1994...	0	9431043602	VZ43	 3400mm
ACELERADOR	2642 HYUAC	H100 ...1998	L4 Cil. 2.5 L	3274043240	AC220	 2265mm
	926 HYUA	H100 Gasolina 1994...	L4 Cil. 2.4 L	3274043653	AC82	 2337mm

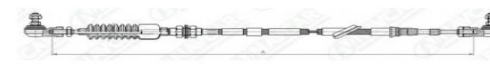

H100 PORTER

KIT CONTROL Y SELECTOR CAMBIO	3962 HYUCC	H100 Porter II Van H100 Truck Diesel 2003-2004 T/Estándar	2.5L 2.5L	43794-4F300	CC86	 A=1772mm/B=1704mm
FRENO DE MANO	4002 HYUFP	H100 Van 1995 - 2004	2.5L	59912-43450	FP414 Trasero Derecho	 2646 mm

DODGE - H-200

SELECTOR CAMBIOS (Selector)	4090 HYUSC	H200-HD35 Camion 2015-2019 T/Estándar	0	43750-5L900	SC43	 2864mm
CONTROL CAMBIOS (Transversal)	4091 HYUCC	H200 HD35 2015-2019 T/Estándar	2.5L	43740-5L900	SC43	 2828mm
FRENO DE MANO	4089 HYUFP	H200 HD35 Camion 2015-2019	2.5L	59910-5K500	FP435 Principal	 3490mm

DODGE - H-300









CONTROL CAMBIOS (Transversal)	4093 HYUCC	H300 HD55 Camion 2016-2019 T/Estándar	4.0L	43750-5L750	SC43	 2967mm
SELECTOR CAMBIOS (Selector)	4092 HYUSC	H300-HD55 Camion 2016-2019 T/Estándar	4.0L	43740-5L750	SC43	 2932mm

Automóvil - Suv - Van - Pickup - Camiones Pesados - Ligeros

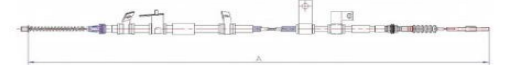
IMPORTANTE. Evite devoluciones o reclamos. Identifique previamente: marca, modelo y año del vehículo. En caso de duda, **CONSULTE** a su asesor.

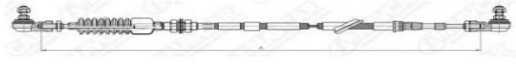
NUESTRA MISIÓN... Ser su aliado en el desarrollo y crecimiento de su negocio

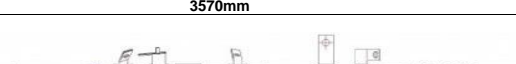
Competimos directamente con los ORIGINALES

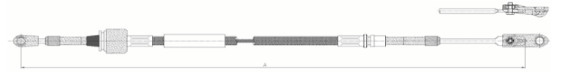
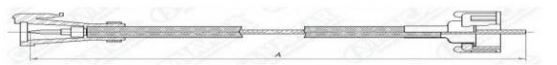
LINEA	CODIGO	MODELO	MOTOR	O.E.M	ARMADO	IMAGEN -- LONGITUD
FRENO DE MANO	4086 HYUFP	H300 2016-2019	4.0L	43750-5L750	FP412 Principal	 3570mm
DODGE - H-400						
CONTROL CAMBIOS (Transversal)	4076 HYUCC	H400 2016-2016 T/Estándar	4.0L	43740-5L500	CC29	 2930mm
SELECTOR CAMBIOS (Selector)	4075 HYUSC	H400 2016-2019 T/Estándar	4.0L	43750-5L500	SC43	 2987mm
FRENO DE MANO	4086 HYUFP	H400 2016-2019	4.0L	43750-5L750	FP412 Principal	 3570mm
DODGE - H-500						
CONTROL CAMBIOS (Transversal)	4076 HYUCC	H500 2016-2016 T/Estándar	4.0L	43740-5L500	CC29	 2930mm
	4076 HYUCC	H500BC 2016-2016 T/Estándar	4.0L	43740-5L500	CC29	 2930mm
SELECTOR CAMBIOS (Selector)	4075 HYUSC	H500 2016-2019 T/Estándar	4.0L	43750-5L500	SC43	 2987mm
	4075 HYUSC	H500BC 2016-2019 T/Estándar	4.0L	43750-5L500	SC43	 2987mm
FRENO DE MANO	4086 HYUFP	H500 2016-2019	4.0L	43750-5L750	FP412 Principal	 3570mm
FRENO DE MANO	4086 HYUFP	H500BC Camion Bus 2016-2019	4.0L	43750-5L750	FP412 Principal	 3570mm
DODGE - LANCER						
CONTROL CAMBIOS (Transversal)	3144 DODSC	Lancer 1983-1989 T/Standar	L4 Cil. 2.2 L 2.6 L	4419831 4269853 4412669	SC54	 1195mm
SELECTOR CAMBIOS (Selector)	3143 DODSC	Lancer 1984-1987 T/Standar	0	4419827	SC54	 1295mm
VELOCIMETRO	3421 AMCVZ	Lancer 1986-1989	V6 Cil. 3.8 L	4897589AA	VZ45	 2046mm

DODGE MINI RAM

Carretero 12700, Col. San Juan de los Rios, Guadalajara, Jalisco
Tel: 46100000, 46100001, 46100002, 46100003, 46100004, 46100005, 46100006, 46100007, 46100008, 46100009, 46100010, 46100011, 46100012, 46100013, 46100014, 46100015, 46100016, 46100017, 46100018, 46100019, 46100020, 46100021, 46100022, 46100023, 46100024, 46100025, 46100026, 46100027, 46100028, 46100029, 46100030, 46100031, 46100032, 46100033, 46100034, 46100035, 46100036, 46100037, 46100038, 46100039, 46100040, 46100041, 46100042, 46100043, 46100044, 46100045, 46100046, 46100047, 46100048, 46100049, 46100050, 46100051, 46100052, 46100053, 46100054, 46100055, 46100056, 46100057, 46100058, 46100059, 46100060, 46100061, 46100062, 46100063, 46100064, 46100065, 46100066, 46100067, 46100068, 46100069, 46100070, 46100071, 46100072, 46100073, 46100074, 46100075, 46100076, 46100077, 46100078, 46100079, 46100080, 46100081, 46100082, 46100083, 46100084, 46100085, 46100086, 46100087, 46100088, 46100089, 46100090, 46100091, 46100092, 46100093, 46100094, 46100095, 46100096, 46100097, 46100098, 46100099, 46100100



Correo: ventas@flexcontrol.com.mx - www.flexcontrol.com.mx - www.cablesnavcar.com

Automóvil - Suv - Van - Pickup - Camiones Pesados - Ligeros



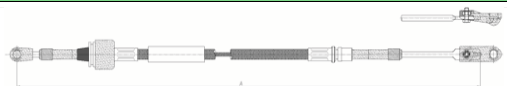

IMPORTANTE. Evite devoluciones o reclamos. Identifique previamente: marca, modelo y año del vehículo. En caso de duda, **CONSULTE** a su asesor.

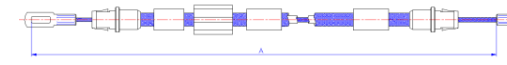
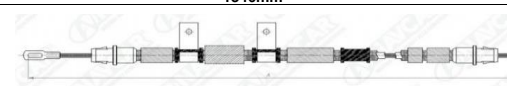
NUESTRA MISIÓN... Ser su aliado en el desarrollo y crecimiento de su negocio

Competimos directamente con los ORIGINALES

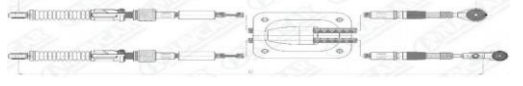
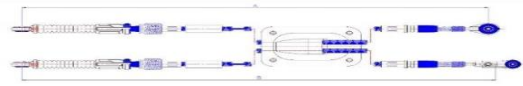
LINEA	CODIGO	MODELO	MOTOR	O.E.M	ARMADO	IMAGEN -- LONGITUD
CONTROL CAMBIOS (Transversal)	3144 DODSC	Mini Ram 1983-1989 T/Estándar	L4 Cil. 2.2 L 2.6 L	4419831 4269853 4412669	SC54	 1195mm
SELECTOR CAMBIOS (Selector)	3143 DODSC	Mini Ram 1984-1987 T/Standar	0	4419827	SC54	 1295mm
FRENO DE MANO	3732 CHRF	Mini Ram Van 2012 - 2014	V6 Cil. 3.6 L	4779806AC	FP362 Trasero Izquierdo	 1346mm
	3725 CHRF	Mini Ram Van 2012 - 2014	V6 Cil. 3.6 L	4779807AC	FP358 Trasero Derecho	 2630mm

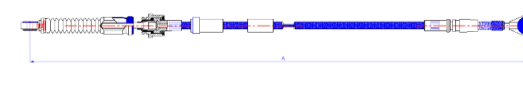
DODGE - NEON

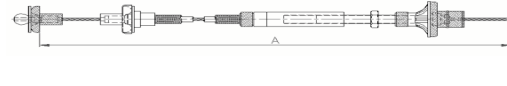
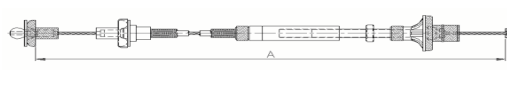
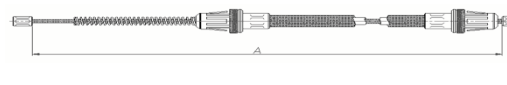
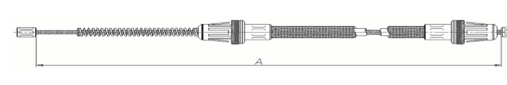
KIT CONTROL Y SELECTOR CAMBIOS	3398 DODCC	Neon 1995-1999 T/Stándar	2.0 L	4641135	CC40	 A=1222mm/B=1222mm
	3821 CHRC	Neon 2000-2006 T/Stándar	1.6 L 2.0 L	04668268AC	CC41	 A=1227mm/B=1250mm
CONTROL CAMBIOS (Transversal)	3821CM CHRC	Neon 2000-2006 T/Stándar	1.6 L 2.0 L	04668268AC	CC41-C	 B=1250mm
SELECTOR CAMBIOS (Selector)	3821SM CHRC	Neon 2000-2006 T/Stándar	1.6 L 2.0 L	04668268AC	CC41-S	 A=1227mm
SELECTOR CAMBIOS	4224 CHRSC	Neon 2000-2005 T/Automatica	2.0L	5274750AF	SC134	 1416mm
EMBRAGUE	2553 CHREM	Neon (122) 1996-1998	L4 Cil. 2.0 L	4670400	EM112 Ajuste Manual	 808mm
	3650 CHREM	Neon 1999-2001	L4 Cil. 2.0 L	4668999AC	EM112 Ajuste Manual	 840mm
FRENO DE MANO	3066 DODFP	Neon SXT SRT-4, SE, R/T 2004	L4 Cil. 2.0 L 2.4 L	4509895AE	FP239 Trasero Izquierdo	 1736mm
	3065 DODFP	Neon SXT SRT-4, SE, R/T 2004	L4 Cil. 2.0 L 2.4 L	4509894AE	FP239 Trasero Derecho	 1710mm

Automóvil - Suv - Van - Pickup - Camiones Pesados - Ligeros

IMPORTANTE. Evite devoluciones o reclamos. Identifique previamente: marca, modelo y año del vehículo. En caso de duda, **CONSULTE** a su asesor.

NUESTRA MISIÓN... Ser su aliado en el desarrollo y crecimiento de su negocio

Competimos directamente con los ORIGINALES











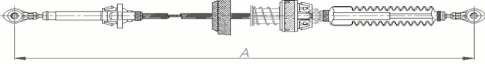



LINEA	CODIGO	MODELO	MOTOR	O.E.M	ARMADO	IMAGEN -- LONGITUD
SOBREMARCHA	2073 CHR SB	Neon R.T 1997 - 1999	0	5277818	SB29	 900mm
ACELERADOR	2227 CHR AC	Neon 1992-1996	L4 Cil. 2.0 L	0	AC178	 760mm
DODGE - NITRO						
KIT CONTROL Y SELECTOR CAMBIOS	3816 CHR CC	Nitro 4x2 4x4 2003 - 2009 T/Standar	V6 Cil. 3.7 L 4.0 L	04668844AD 04668844AA 04668844AB 04668844AC	CC41	 A=1273mm/B=1375mm
EMBRAGUE	3809 CHR EM	Nitro 4x2, 4x4 2007	V6 Cil. 3.7 L	04578930AA	EM112	 778mm
DODGE - OMNI						
CONTROL CAMBIOS (Transversal)	3144 DOD SC	Omni T/Standar	L4 Cil. 2.2 L 2.6 L	4419831 4269853 4412669	SC54	 1195mm
EMBRAGUE	1655 DOD E	Omni 1982-1983	L4 Cil. 2.4 L	4505539 4369592	EM76	 1050mm
	1666 DOD E	Omni 024 1983	L4 Cil. 2.6 L	4505533 4505341	EM76	 1085mm
ACELERADOR	2178 CHR AC	Omni 1990	L4 Cil. 2.5 L	5277832	AC142	 1113mm
DODGE - PHANTOM						
EMBRAGUE	2287 DOD EM	Phantom 1992-1994	L4 Cil. 2.5 L	4670754	EM76	 1142mm
DODGE - RAM 20-50						
EMBRAGUE	1340 MITE	Ram 50 Traccion 2R 1979 - 1986	2.0 L 2.6 L	MB012460	EM43	 826mm
ACELERADOR	2319 MIT AC	Ram 20 (2000A) 1987 - 1989	V8 Cil. 5.2 L 5.9 L	MB322754	AC163	 1062mm
	2319 MIT AC	Ram 50 (2600W) 1987 - 1989	V8 Cil. 5.2 L 5.9 L	MB322754	AC163	 1062mm
	2318 MIT AC	Ram 50 2400T 1990 - 1993	V8 Cil. 5.2 L 5.9 L	MB539514	AC162	 1002mm

Automóvil - Suv - Van - Pickup - Camiones Pesados - Ligeros

IMPORTANTE. Evite devoluciones o reclamos. Identifique previamente: marca, modelo y año del vehículo. En caso de duda, **CONSULTE** a su asesor.

NUESTRA MISIÓN... Ser su aliado en el desarrollo y crecimiento de su negocio

Competimos directamente con los ORIGINALES

LINEA	CODIGO	MODELO	MOTOR	O.E.M	ARMADO	IMAGEN -- LONGITUD
SELECTOR CAMBIOS	2752 AMCSC	Ram 1500 4x4 MPI, 2006 T/Automática	V8 Cil. 4.7 L	52104095	SC29	 1098mm
SELECTOR CAMBIOS	4281 DODSC	Ram 1500 2005-2007 T/Automática	3.7L	52107847AM	SC118	 1768mm
SELECTOR CAMBIOS	4150 CHRSC	Ram 2500 2007-2009 T/Automática	5.9L	52107847AM	SC118	 1648mm
SELECTOR CAMBIOS	4150 CHRSC	Ram 3500 2007-2009 T/Automática	6.7L	52107847AM	SC118	 1648mm
SELECTOR CAMBIOS	4289 DODSC	Ram 2500 2007-2009 T/Automática	5.6L	52107847AM	SC118	 1842mm
SELECTOR CAMBIOS	4289 DODSC	Ram 3500 2007-2009 T/Automática	6.7L	52107847AM	SC118	 1842mm
FRENO DE MANO	4052 DODFP	Ram 2500 2010...	5.7L	55398792AA	FP3 Principal	 258mm
FRENO DE MANO	2947 DODFP	Ram 1500, Van 318 CID Van 360 CID 1998 - 2000	V8 Cil. 5.2 L	0	FP240	 1748mm
FRENO DE MANO	3069 DODFP	Ram 2500-3500 2003-2005	5.9L	521211101AA	FP263	 1505mm
FRENO DE MANO	4108 DODFP	Ram 1500-2500 2010-2018	3.0L 3.6L 4.7L 5.7L	55398320AC	FP424 Principal	 1460mm
FRENO DE MANO	3740 DODFP	Ram 3500 Cab And Chassis 2000 - 2001	V6 Cil. 3.6 L	52010070AA 52010070AB	FP3 Intermedio	 647mm
ACELERADOR	3711 DODAC	Ram 1500, 2500, 3500 ST, Gas 1997 - 2001	V8 Cil. 5.2 L 5.9 L	53031602AB	AC266	 1212mm
	3810 CHRAC	Ram 1500, 2500, 3500 "Magnum" 1994-2002	V8 Cil. 5.2 L 5.9 L	52079351 53031504AB 53031504	AC269	 1191mm
SOBREMARCHA	3710 DODSB	Ram 1500, 2500, 3500 "Magnum" 1997-1999	V6 Cil. 3.9 L 5.2 L	52104030A	SB36	 1566mm
			V8 Cil. 5.9 L			
SOPORTE COMPUERTA	3796 DODSO	Ram 1500, 2500, 3500 2003-2008	V6 Cil. 3.7 L V8 Cil. 4.7 L	55276074AC 55276074AE	CO6	 555mm

DODGE - RAM 4500/5500

Encino 1287 col. del Fresno Guadalajara Jal.



Tel. Multilínea (33) 3811 6917 - Servi-Cliente Cel. 33 1992 6768 - Guadalajara, Jalisco
Correo: ventas@flexcontrol.com.mx - www.flexcontrol.com.mx - www.cablesnavcar.com

Automóvil - Suv - Van - Pickup - Camiones Pesados - Ligeros

IMPORTANTE. Evite devoluciones o reclamos. Identifique previamente: marca, modelo y año del vehículo. En caso de duda, **CONSULTE** a su asesor.

NUESTRA MISIÓN... Ser su aliado en el desarrollo y crecimiento de su negocio

Competimos directamente con los ORIGINALES

LINEA	CODIGO	MODELO	MOTOR	O.E.M	ARMADO	IMAGEN -- LONGITUD
FRENO DE MANO	4077 DODFP	Ram 4500 2008-2010	6.7L	52013840AB	FP3	 1880mm
	4077 DODFP	Ram 5500 2008-2010	6.7L	52013840AB	FP3	 1880mm

DODGE - RAM CHARGER

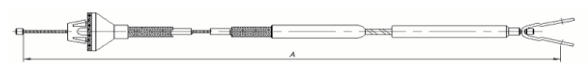
ACELERADOR	1584 DODA	Ram charger 1978 -1979	V6 Cil. 3.7 L	3820952	AC75	 695mm
	1581 DODA	Ram Charger 1980 - 1987	V8 Cil. 5.2 L 5.9 L	4241224	AC77	 675mm

DODGE - RAM LARAMIE

ACELERADOR	3711 DODAC	Ram Laramie, Sport Gas 1997 - 2001	V8 Cil. 5.2 L 5.9 L	53031602AB	AC266	 1212mm
------------	----------------------	--	---------------------------	------------	-------	--





DODGE - RAM SPORT

ACELERADOR	3711 DODAC	Ram Sport Gas 1997 - 2001	V8 Cil. 5.2 L 5.9 L	53031602AB	AC266	 1212mm
------------	----------------------	---------------------------------	---------------------------	------------	-------	---

DODGE - RAMPAGE

EMBRAGUE	1666 DODE	Rampage 1983	L4 Cil. 2.6 L	4505533 4505341	EM76	 1085mm
----------	---------------------	-----------------	------------------	--------------------	------	--

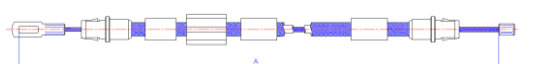
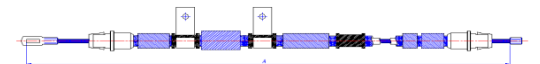
DODGE - ROYAL

CONTROL CAMBIOS (Transversal)	3144 DODSC	Royal 1983-1989 T/Estándar	L4 Cil. 2.2 L 2.6 L	4419831 4269853 4412669	SC54	 1195mm
SELECTOR CAMBIOS (Selector)	3143 DODSC	Royal Mini R 1984-1987 T/Standar	0	4419827	SC54	 1295mm
FRENO DE MANO	3732 CHRFP	Royal Mini R 2012 - 2014	V6 Cil. 3.6 L	4779806AC	FP362 Trasero Izquierdo	 1346mm
	3725 CHRFP	Royal Mini R 2012 - 2014	V6 Cil. 3.6 L	4779807AC	FP358 Trasero Derecho	 2630mm
ACELERADOR	2075 CHRAC	Royal 1989	V6 Cil. 3.0 L	4459135	AC142	 948mm

DODGE - SHADOW







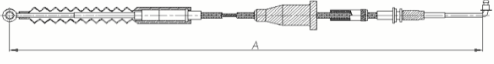

Encino 1287 col. del Fresno Guadalupe Jal.

Automóvil - Suv - Van - Pickup - Camiones Pesados - Ligeros

IMPORTANTE. Evite devoluciones o reclamos. Identifique previamente: marca, modelo y año del vehículo. En caso de duda, **CONSULTE** a su asesor.

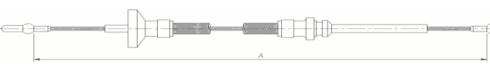
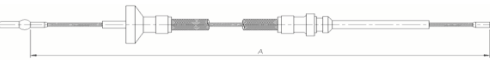
NUESTRA MISIÓN... Ser su aliado en el desarrollo y crecimiento de su negocio

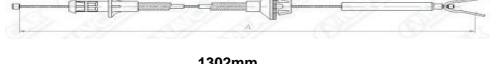
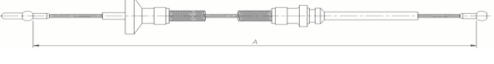
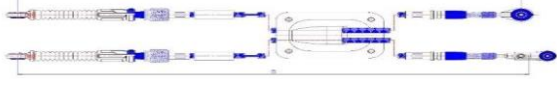
Competimos directamente con los ORIGINALES



LINEA	CODIGO	MODELO	MOTOR	O.E.M	ARMADO	IMAGEN -- LONGITUD
SELECTOR CAMBIOS	2117 CHRSC	Shadow 1991-1994 T/Automática	L4 Cil. 2.2 L	4543042	SC23	 1422mm
	3142 CHRSC	Shadow ES SE 1990-1994 T/Estándar	L4 Cil. 2.5 L V6 Cil. 3.0 L	4446858 4504340	SC53	 1398mm
	3143 DODSC	Shadow (USA) 1984-1987 T/Estándar	0	4419827	SC54	 1295mm
CONTROL CAMBIOS (Transversal)	3144 DODSC	Shadow 1983-1989 T/Estándar	L4 Cil. 2.2 L 2.6 L	4419831 4269853 4412669	SC54	 1195mm
EMBRAGUE	1721 DODE	Shadow 5 Velocidades 1987 - 1987	L4 Cil. 2.2 L	4377769	EM76	 1050mm
	1655 DODE	Shadow 1989-1990	L4 Cil. 2.4 L	4505539 4369592	EM76	 1050mm
	1666 DODE	Shadow 1989-1990	L4 Cil. 2.6 L	4505533 4505341	EM76	 1085mm
ACELERADOR	2226 DODAC	Shadow Turbo fuel injection 1991-1995	L4 Cil. 2.5 L	5277825	AC174	 1173mm
	2224 DODAC	Shadow 1989,	4 CIL	0	AC175	 1302mm
DODGE - SPIRIT						
EMBRAGUE	2287 DODEM	Spirit R/T 1992-1994	L4 Cil. 2.5 L	4670754	EM76	 1142mm
DODGE - STRATUS						
KIT CONTROL Y SELECTOR CAMBIOS	3821 CHRCC	Stratus 2002 T/Standar	L4 Cil. 2.4 L V6 Cil. 3.0 L	04668268AC	CC41	 A=1227mm/B=1250mm
CONTROL CAMBIOS (Transvesal)	3821CM CHRCC	Stratus 2002 T/Standar	L4 Cil. 2.4 L V6 Cil. 3.0 L	04668268AC	CC41-C	 B=1250mm
SELECTOR CAMBIOS (Selector)	3821SM CHRCC	Stratus 2002 T/Standar	L4 Cil. 2.4 L V6 Cil. 3.0 L	04668268AC	CC41-S	 A=1227mm

Automóvil - Suv - Van - Pickup - Camiones Pesados - Ligeros

IMPORTANTE. Evite devoluciones o reclamos. Identifique previamente: marca, modelo y año del vehículo. En caso de duda, **CONSULTE** a su asesor.

NUESTRA MISIÓN... Ser su aliado en el desarrollo y crecimiento de su negocio

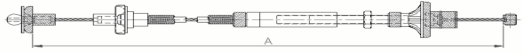
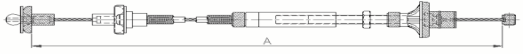
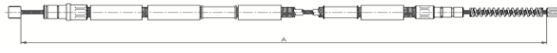

Competimos directamente con los ORIGINALES

LINEA	CODIGO	MODELO	MOTOR	O.E.M	ARMADO	IMAGEN -- LONGITUD
SELECTOR CAMBIOS	4224 CHRSC	Stratus 2000-2005 T/Automático	2.0L	5274750AF	SC134	 1416mm
EMBRAGUE	3808 CHREM	Stratus 1995-2000	L4 Cil. 2.0 L 2.4 L 2.5 L	04593333 04593103	EM112	 760mm
	3809 CHREM	Stratus SE, SXT 2001 - 2004	V6 Cil. 3.7 L	04578930AA	EM112	 778mm
FRENO DE MANO	3171 DODFP	Stratus R/T Coupe 2001-2005	V6 Cil. 3.0 L	0	FP286 Trasero Derecho	 1797mm
	2846 DODFP	Stratus 2001-2004	V6 Cil. 2.4 L 3.0 L	0	FP286 Trasero Derecho	 1771mm

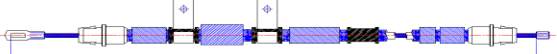
DODGE - TRUCK CARGO

FRENO DE MANO	3732 CHRFP	Truck Cargo Van 2012 - 2014	V6 Cil. 3.6 L	4779806AC	FP362 Trasero Izquierdo	 1346mm
	3725 CHRFP	Truck Cargo Van 2012 - 2014	V6 Cil. 3.6 L	4779807AC	FP358 Trasero Derecho	 2630mm

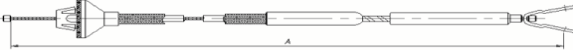
DODGE - W100 - W150 - W200 - W250 - W300 - WW350

ACELERADOR	2178 CHRAC	W150- W300 Pickups 1990	0	5277832	AC142	 1113mm
	1581 DODA	W100, W150, W200, W250, W300, W350 1980 - 1987	V8 Cil. 5.2 L 5.9 L	4241224	AC77	 675mm
ACELERADOR	1724 DODA	W 100 - 350 Series Pickups 1980 - 1987	V8 Cil. 5.2 L	4275940	AC77	 695mm

FAW

FAW

APERTURA CAJUELA	3826 FAWAB	Faw 2013...	V5 Cil 1.4L	64607-TKA00	AB2	 3619mm
------------------	----------------------	----------------	----------------	-------------	-----	--

FORD





FORD - AEROSTAR

Automóvil - Suv - Van - Pickup - Camiones Pesados - Ligeros

IMPORTANTE. Evite devoluciones o reclamos. Identifique previamente: marca, modelo y año del vehículo. En caso de duda, **CONSULTE** a su asesor.

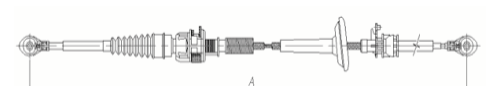
NUESTRA MISIÓN... Ser su aliado en el desarrollo y crecimiento de su negocio

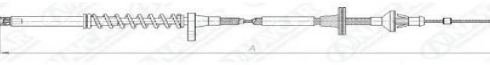

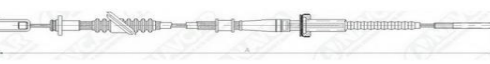
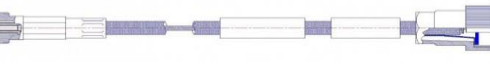

Competimos directamente con los ORIGINALES

LINEA	CODIGO	MODELO	MOTOR	O.E.M	ARMADO	IMAGEN -- LONGITUD
SELECTOR CAMBIOS	1782 FORSC	Aerostar 1990... T/Automática	3.0 L 4.0 L	F29A7E395EH	SC17	 1596mm
SOBREMARCHA	4138 FORSB	Aerostar 1987-1990	0	0	SB37	 1294mm
VELOCIMETRO	2703 FORVZ	Aerostar 1985 - 1997	L4 Cil. 1.3 L	E5UZ9A820A E69Z9A820B	VZ88	 2337mm
ACELERADOR	1600 EFOA	Aerostar 1987 - 88	V6 Cil. 3.0 L	E79Z9A758A	AC180	 543mm
APERTURA CHAPA	3783 FORAP	Aerostar	V6 Cil. 4.0 L	0	ACH7 Delantero	 840mm

FORD - ASPIRE

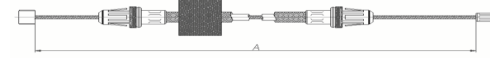
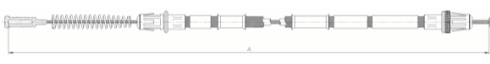
EMBRAGUE	2481 FOREM	Aspire 1994 - 1997	L4 Cil. 1.3 L	F4BZ7K553A	EM24	 723mm
VELOCIMETRO	3053 FORVZ	Aspire SE 1988-1997	L4 Cil. 1.3 L	E7GZ17260A F4BZ17260B	VZ78 Tramo inferior	 295mm

FORD - BRONCO

SELECTOR CAMBIOS	1780 FORSC	Bronco E40D 1992... T/Automática	V8 Cil. 4.9 L 5.0 L 5.8 L	F5TZ7E395A	SC17	 1391mm
FRENO DE MANO	2586 FORFP	Bronco 1992 - 1996	V8 Cil. 4.9 L 5.0 L 5.8 L	F2TZ2853A F6TZ2853DA	FP459	 1130mm
	1706 EFOF	Bronco, 1992 - 1996 1996 - 1998	V8 Cil. 4.9 L 5.0 L 5.8 L	F2TZ2853A	FP458 Principal	 1132mm
FRENO DE MANO	4130 FORFP	Bronco 1980-1983	0	E07Z-2A635-J E07Z-2A635-A E07Z-2A635-J E1TZ-2A635-E E3TZ-2A635-C	FP243 Trasero Derecho	 2355mm
	4135 FORFP	Bronco 1980-1989	0	E07Z-2A635-B E07Z-2A635-K E1TZ-2A635-F E3TZ-2A635-D E5TZ-2A635-B	FP243 Trasero Izquierdo	 1520mm
	4137 FORFP	Bronco 1984-1991	0	0	FP261 Trasero Derecho	 2344mm

Encino 1287 col. del Fresno Guadalajara Jal.











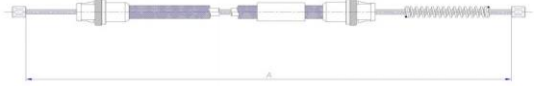

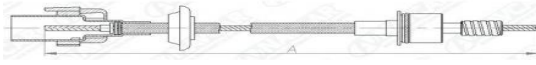
Tel. Multilínea (33) 3811 6917 - Servi-Cliente Cel. 33 1992 6768 - Guadalajara, Jalisco
Correo: ventas@flexcontrol.com.mx - www.flexcontrol.com.mx - www.cablesnavcar.com

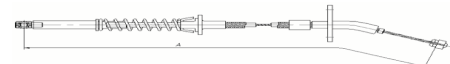
Automóvil - Suv - Van - Pickup - Camiones Pesados - Ligeros

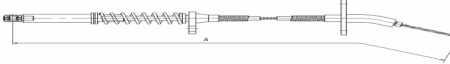
IMPORTANTE. Evite devoluciones o reclamos. Identifique previamente: marca, modelo y año del vehículo. En caso de duda, **CONSULTE** a su asesor.

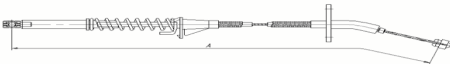
NUESTRA MISIÓN... Ser su aliado en el desarrollo y crecimiento de su negocio

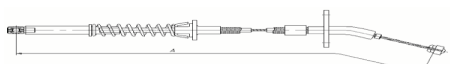
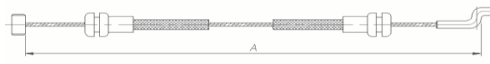
Competimos directamente con los ORIGINALES









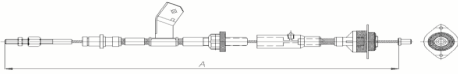
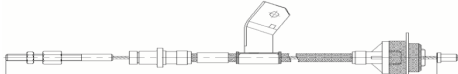

LINEA	CODIGO	MODELO	MOTOR	O.E.M	ARMADO	IMAGEN -- LONGITUD
	3707 FORFP	Bronco 1987-1991	0	0	FP369 Trasero Izquierdo	 1503mm
SOBREMARCHA	4138 FORSB	Bronco 1988-1991	4.9L 5.8L	E6TZ-7A187-D	SB37	 1294mm
VELOCIMETRO	2536 FORVZ	Bronco Traccion 4x4 1985 - 1991	L4 Cil. 1.3 L	E4UZ17260B	VZ81	 2298mm
	2541 FORVZ	Bronco 1983 - 1990	0	E3TZ17260C D6DZ17260A	VZ85	 1554mm
ACELERADOR	2025 FORAC	Bronco Motor 300, 302, 351 1990 - 1991	V8 Cil. 5.2 L 5.9 L	E9TZ9A758P	AC110	 1074mm
	399 EFOA	Bronco Motor 302-351M 1981 - 1985	V6 Cil. 4.9 L 2.8 L	E1TZ9A758E	AC45	 568mm
	2098 FORAC	Bronco Fuel Inyection 1980-1986	V6 Cil. 4.9 L 2.8 L	D4UZ9A758G	AC42	 1040mm
	2486 FORAC	Bronco 300 1991 - 1996	V6 Cil. 4.9 L 2.8 L	F4TZ9A758M	AC110	 997mm
	397 EFOA	Bronco U150 Wagon 1983 - 1986	V6 Cil. 4.9 L 2.8 L	E3TZ9A758B	AC42	 780mm
	1525 EFOA	Bronco U150 Wagon Motor 302 - 351W 1985 - 1990	V6 Cil. 4.9 L 2.8 L	E5TZ9A758A	AC45	 1065mm
	2504 FORAC	Bronco 1991 - 1993	V8 Cil. 5.0 L 5.8 L	F1TZ9A758K	AC110	 767mm
	2706 FORAC	Bronco 1991 - 1993	V8 Cil. 5.0 L	F1TZ9A758J	AC110	 991mm
APERTURA CHAPA	236 EFOC	Bronco 1992...	V6 Cil. 2.7 L V8 Cil. 4.7 L	F3TZ15221A00A	ACH1Trasero Derecho/Izquierdo	 575mm
SOPORTE CAJUELA	464 EFOC	Bronco 1983 - 1996	V6 Cil. 4.7 V8 Cil. 4.7 L	E3TZ9843052A	CO4	 454mm
FORD - BULLITT						
	1765 FOREM	Bullitt 1996 - 2003	0	XR3Z7K553BA F7ZZ7K553AA F6ZZ7535AA	EM82	 1823mm

Automóvil - Suv - Van - Pickup - Camiones Pesados - Ligeros

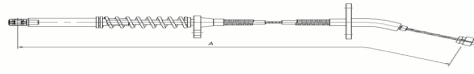
IMPORTANTE. Evite devoluciones o reclamos. Identifique previamente: marca, modelo y año del vehículo. En caso de duda, **CONSULTE** a su asesor.

NUESTRA MISIÓN... Ser su aliado en el desarrollo y crecimiento de su negocio

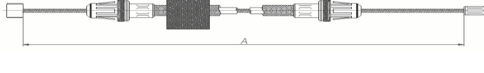
Competimos directamente con los ORIGINALES

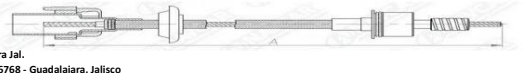







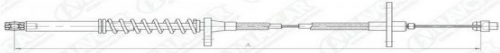
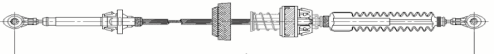
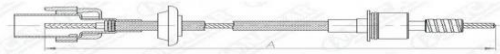
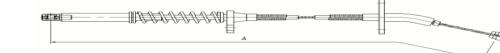

LINEA	CODIGO	MODELO	MOTOR	O.E.M	ARMADO	IMAGEN -- LONGITUD
EMBRAGUE	1835 FOREM	Bullitt 1996 - 2003	0	XR3Z7K553BA F7ZZ7K553AA F6ZZ7535AA	EM86 Cable/ Funda Ajustable	 1823mm
		FORD - COBRA				
EMBRAGUE	1765 FOREM	Cobra 1996 - 2003	0	XR3Z7K553BA F7ZZ7K553AA F6ZZ7535AA	EM82 Cable Ajustable	 1823mm
		1835 FOREM	Cobra 1996 - 2003	0	XR3Z7K553BA F7ZZ7K553AA F6ZZ7535AA	EM86 Cable/ funda Ajustable
FORD - CONQUISTADOR						
VELOCIMETRO	642 FORVZ	Conquistador 1979 - 1980	V8 Cil. 5.0 L 5.7 L 6.6 L	D50F-9A820-CA	VZ30	 340mm
ACELERADOR	471 EFOA	Conquistador 1982 - 1985	0	E5DZ9A758C	AC42	 475mm
FORD - COGUAR						
EMBRAGUE	1710 EFOE	Cougar 1981-1982	L6 Cil. 3.3 L V8 Cil. 4.2 L	D9BZ7K553F	EM75	 1020mm
ACELERADOR	471 EFOA	Cougar 1982 - 1985	0	E5DZ9A758C	AC42	 475mm
ACELERADOR	3606 FORAC	Cougar 1983-1989	V8 Cil. 5.0 L	E2SZ-9A758-C	AC43	 487mm
FORD - CROWN VICTORIA						
SELECTOR CAMBIOS	4012 FORSC	Crown Victoria 2008-2011 T/Automática	V6 Cil. 4.6L	6W1Z-7E395-A	SC93	 2121mm
SELECTOR CAMBIOS	4013 FORSC	Crown Victoria 1996-2002 T/Automática	4.6L	F8AZ-7E395-BA	SC94	 1729mm
FRENO DE MANO	2826 FORFP	Crown Victoria 2003 - 2004	V8 Cil. 4.6 L	0	FP459 Principal	 1400mm
VELOCIMETRO	3052 FORVZ	Crown Victoria 1960-1981	V6 Cil.	B9MF17260-B C0MF17260-A C6DZ17260-B	VZ84	 1707mm
	2165 FORVU	Crown Victoria C6 W/O Cruise 1969	V6 Cil.	D4ZZ17260A	VZ81	 1986mm

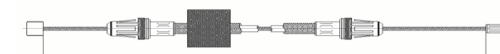
Automóvil - Suv - Van - Pickup - Camiones Pesados - Ligeros

IMPORTANTE. Evite devoluciones o reclamos. Identifique previamente: marca, modelo y año del vehículo. En caso de duda, **CONSULTE** a su asesor.

NUESTRA MISIÓN... Ser su aliado en el desarrollo y crecimiento de su negocio

Competimos directamente con los ORIGINALES







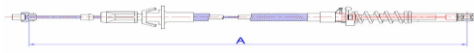
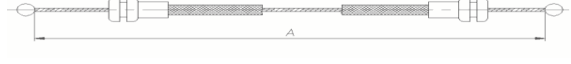

LINEA	CODIGO	MODELO	MOTOR	O.E.M	ARMADO	IMAGEN -- LONGITUD
ACELERADOR	3606 FORAC	Crown Victoria 1983-1989	V8 Cil. 5.0 L	E2SZ-9A758-C	AC43	 487mm
FORD - CUSTOM						
SELECTOR CAMBIOS	3416 GMSCC	Custom 1986-1996 T/Automática	V6 Cil. 3.8 L	12552510	SC29	 1504mm
VELOCIMETRO	2165 FORVU	Custom 1969	V6 Cil.	D4ZZ17260A	VZ81	 1986mm
ACELERADOR	396 EFOA	Custom Motor 302-351 1979-1980	V8 Cil. 4.9 L	E0AZ9A758A	AC42	 750mm
FORD - E100 - E150 - E250 - E300 - E350						
SELECTOR CAMBIOS	1783 FORSC	E150 / E250 / E350 w/E40D 1992... T/Automática	V8 Cil. 4.9 L 5.0 L 5.8 L	F2UZ7E395A	SC17	 1855mm
FRENO DE MANO	2763 FORFP	E300 / E350 1992 - 1996	V6 Cil. 4.9 L V8 Cil. 5.8 L	F2UZ2853A F4UZ2853A	FP459 Principal	 2532mm
	3100 FORFP	E350 Super Wagon 1984-1987	L6 Cil. 4.9 L V8 Cil. 5.8 L 6.9 L 7.5 L	E4UZ2853C E7UZ2853C	FP240 Principal	 3790mm
VELOCIMETRO	2536 FORVZ	E150 / E250 / E350 1985 - 1991	L4 Cil. 1.3 L	E4UZ17260B	VZ81	 2298 mm
	1694 FORVZ	E250 / E350 1975-1991	L4 Cil. 1.3 L	D5UZ17260-C	VZ27	 2740 mm
	2703 FORVZ	E150 / E350 1985 - 1997	L4 Cil. 1.3 L	E5UZ9A820A E69Z9A820B	VZ88	 2337mm
ACELERADOR	1594 EFOA	E100 / E350 1981 - 1982	V8 Cil. 4.9 L	E1TZ9A758C	AC45	 770mm
	2098 FORAC	E100 / E350 Series Vans 1974 - 1988	V6 Cil. 4.9 L 2.8 L	D4UZ9A758G	AC42	 1040mm
	2569 FORAC	E350 Chassis 300 1984-1988	V6 Cil. 4.9 L	E4UZ9A758B	AC42	 1289mm
	1754 FORAC	E150 - 250 1986 - 1989	V6 Cil. 4.9 L	E4UZ9A758A	AC130	 1100mm

Automóvil - Suv - Van - Pickup - Camiones Pesados - Ligeros

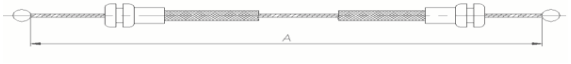
IMPORTANTE. Evite devoluciones o reclamos. Identifique previamente: marca, modelo y año del vehículo. En caso de duda, **CONSULTE** a su asesor.

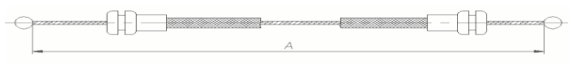
NUESTRA MISIÓN... Ser su aliado en el desarrollo y crecimiento de su negocio

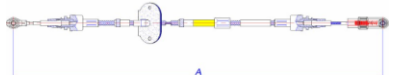
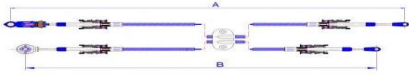
Competimos directamente con los ORIGINALES







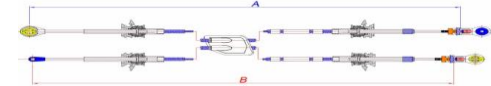

LINEA	CODIGO	MODELO	MOTOR	O.E.M	ARMADO	IMAGEN -- LONGITUD
	1754 FORAC	E250 / E350 Series Vans 1992 - 1996	V6 Cil. 4.9 L	E4UZ9A758A	AC130	 1100mm
	4309 FORAC	E-250 E-350 1992 - 1996	0	F2UZ9A758C	AC328	 838mm
APERTURA CHAPA	3792 FORAP	Econoline	V6 Cil. 3.7 L V8 Cil. 4.7 L	0	ACH2	 395mm
	3787 FORAP	Econoline Van 1996-2007	V6 Cil. 3.7 V8 Cil. 4.7 L	0	ACH6 Corrediza	 787mm
	3786 FORAP	Econoline Van 1996-2007	V6 Cil. 3.7 V8 Cil. 4.7 L	0	ACH2 Lateral Inferior	 825mm
	3788 FORAP	Econoline Van 1996-2007	V6 Cil. 3.7 V8 Cil. 4.7 L	0	ACH5 Trasera Derecha	 815mm
	3785 FORAP	Econoline Van Carga 1996-2008	V6 Cil. 3.7 V8 Cil. 4.7 L	0	ACH2 Corrediza	 261mm
APERTURA CHAPA	238 EFOC	E150 / E350 1992...	V6 Cil. 2.7 V8 Cil. 4.7 L	F2UZ15266A46A	ACH2 Pasajeros Larga	 483mm
	237 EFOC	E150 / E350 1992...	V6 Cil. 2.7 V8 Cil. 4.7 L	F2UZ15264A65A	ACH2	 364mm
FORD - ESCAPE						
SELECTOR CAMBIOS	4395 FORSC	Escape 2013-2019	2.0 L 2.5 L	DJ5Z-7E395-E CJ5Z-7E395-A	SC166	 1530mm
FORD - ECOSPORT						
KIT CONTROL Y SELECTOR CAMBIOS	4006 FORCC	Ecosport 2004-2008 T/Standar	2.0 L	2S65-7E395-BA 2S65-7E395-BD 2S65-7E395-BB 2S65-7E395-BE	CC93	 A=1707mm/B=1515mm
KIT CONTROL Y SELECTOR CAMBIOS	4240 FORCC	Ecosport 2013-2017 T/Estandar	2.0L	CN15-7E395-AB	CC119	 A=1490mm/B=1638mm

Automóvil - Suv - Van - Pickup - Camiones Pesados - Ligeros

IMPORTANTE. Evite devoluciones o reclamos. Identifique previamente: marca, modelo y año del vehículo. En caso de duda, **CONSULTE** a su asesor.

NUESTRA MISIÓN... Ser su aliado en el desarrollo y crecimiento de su negocio

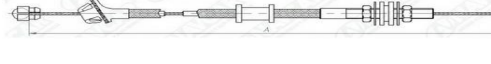
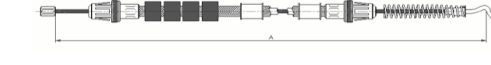
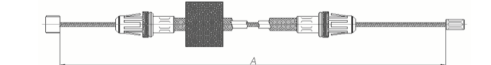
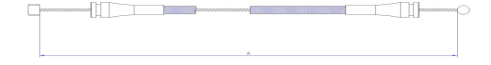
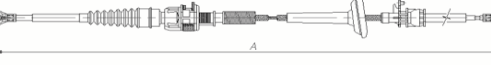
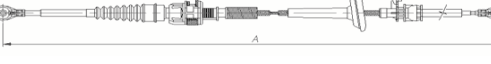
Competimos directamente con los ORIGINALES





LINEA	CODIGO	MODELO	MOTOR	O.E.M	ARMADO	IMAGEN -- LONGITUD
KIT CONTROL Y SELECTOR CAMBIOS	4342 FORCC	Ecosport 2010-2015 T/Estandar	1.6L	AN157E395CA	CC134	 A=1496mm/B=1718mm
SELECTOR CAMBIOS	4178 FORSC	Ecosport 2006-2012 T/Automática	2.0L	7N157E395AB	SC127	 1632mm
FRENO DE MANO	4183 FORFP	Ecosport 2004 - 2012	2.0L	6N15-2A603-AD	FP478Trasero Derecho/Izquierdo	 A=1555mm/B=1568mm
ACELERADOR	4039 FORAC	Ecosport 2003...	1.6 Litros	2S65-9C799-AC	AC124	 995mm
FORD - ESCORT						
EMBRAGUE	2281 FOREM	Escort 1981-1990	L4 Cil. 2.0 L	E3FZ7K553A/B	EM71	 662mm
ACELERADOR	1590 EFOA	Escort 1981 - 1990	V6 Cil. 1.6 L 1.9 L 2.0 L 2.3 L 2.5 L	E2FZ9A758A	AC42	 1166mm
	2321 MAZAC	Escort 1991-1995	L4 Cil. 1.8 L	BB70-41-660B	AC33	 1122mm
FORD - EXCURSION						
FRENO DE MANO	2819 FORFP	Excursion 2000 - 2005	V8 Cil. 5.4 L	YC3Z2A635BA	FP263	 1961mm
FORD - EXPEDITION						
FRENO DE MANO	2623 FORFP	Expedition 1996 - 1999	V8 Cil. 5.4 L	F75Z2853AA	FP459 Principal	 1684mm
APERTURA CHAPA	3789 FORAP	Expedition	V6 Cil. 3.7 L V8 Cil. 4.7 L	0	ACH6	 565mm
FORD - EXPLORER						
SELECTOR CAMBIOS	1780 FORSC	Explorer 1998 T/Automática	V8 Cil. 4.9 L 5.0 L 5.8 L	F5T7E395A	SC17	 1391mm
SELECTOR CAMBIOS	3384 FORSC	Explorer Sport 1997-2003 T/Automática	V6 Cil. 4.0 L V8 Cil. 4.6 L	F77Z7E395LB	SC17	 1294mm
	3721 FORSC	Explorer Sport 4X4 2006 T/Automática	V6 Cil. 4.0 L V8 Cil. 4.6 L	7L2P-7E395-BA	SC72	 1131mm

Automóvil - Suv - Van - Pickup - Camiones Pesados - Ligeros



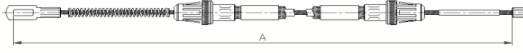
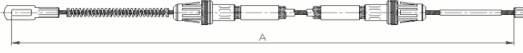



IMPORTANTE. Evite devoluciones o reclamos. Identifique previamente: marca, modelo y año del vehículo. En caso de duda, **CONSULTE** a su asesor.

NUESTRA MISIÓN... Ser su aliado en el desarrollo y crecimiento de su negocio

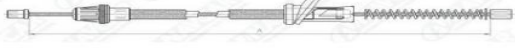
Competimos directamente con los ORIGINALES

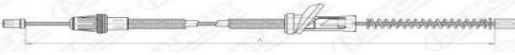
LINEA	CODIGO	MODELO	MOTOR	O.E.M	ARMADO	IMAGEN -- LONGITUD
	3714 FORSC	Explorer XLS, XLT, Limited, Eddie Bauer 2002 - 2005 T/Automática	V6 Cil. 4.0 L V8 Cil. 4.6 L	1L2Z-7E395AC	SC72	 1225mm
FRENO DE MANO	3071 FORFP	Explorer Sport Trac 2003-2005	V6 Cil. 4.0 L	3L2Z2A635AB	FP220 Trasero Izquierdo	 1044mm
	3070 FORFP	Explorer Sport Trac 2003-2005	V6 Cil. 4.0 L	3L2Z2A635AA	FP220 Trasero Derecho	 1957mm
ACELERADOR	1590 EFOA	Explorer 1981 - 1990	V6 Cil. 1.6 L 1.9 L 2.0 L 2.3 L 2.5 L	E2FZ9A758A	AC42	 1166mm
	4030 FORAC	Explorer Sport 2001-2003	V8 Cil. 6.0 L	2L5Z9A758CA	AC279	 967 mm
APERTURA COFRE	3399 FORCA	Explorer 1997	V6 Cil. 4.0 L V8 Cil. 5.0 L	F77Z16916BA	CP26	 2232mm

FORD - F100

FRENO DE MANO	4130 FORFP	F-100 1980-1983	0	E07Z-2A635-J E07Z-2A635-A E07Z-2A635-J E1TZ-2A635-E E3TZ-2A635-C	FP243 Trasero Derecho	 2355mm
	4131 FORFP	F-100 1980-1991	0	E8TZ-2A635-B	FP214 Trasero Izquierdo	 1685mm
	4135 FORFP	F-100 1980-1984	0	E0TZ-2A635-B E0TZ-2A635-K E1TZ-2A635-F E3TZ-2A635-D E5TZ-2A635-B	FP243 Trasero Izquierdo	 1520mm
	4136 FORFP	F-100 1980-1994	0	0	FP214 Trasero Derecho	 2500mm
VELOCIMETRO	640 FORVZ	F-100 1978 -1980	0	D7TA17260MA	VZ27	 1891 mm
ACELERADOR	1440 EFOA	F-100 1981 - 1983	V6 Cil. 4.9 L	E1TZ9A758B	AC42	 563mm
	397 EFOA	F-100 1983 - 1986	V6 Cil. 4.9 L 2.8 L	E3TZ9A758B	AC42	 780mm
	1594 EFOA	F-100 1980 - 1982	V8 Cil. 4.9 L	E1TZ9A758C	AC45	 770mm



Encino 3287 col. del Fresno Guadalajara Jal.

Automóvil - Suv - Van - Pickup - Camiones Pesados - Ligeros







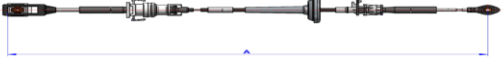
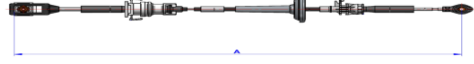
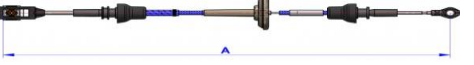
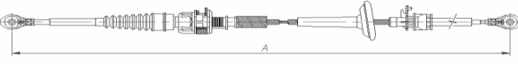

IMPORTANTE. Evite devoluciones o reclamos. Identifique previamente: marca, modelo y año del vehículo. En caso de duda, **CONSULTE** a su asesor.

NUESTRA MISIÓN... Ser su aliado en el desarrollo y crecimiento de su negocio

Competimos directamente con los ORIGINALES

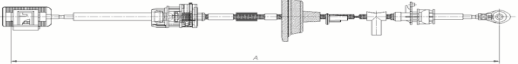
LINEA	CODIGO	MODELO	MOTOR	O.E.M	ARMADO	IMAGEN -- LONGITUD
	2232 FORAC	F-100 1979-1992	V6 Cil. 4.9 L	E0TD9A758AD/AC	AC42	 545mm
	1526 EFOA	F-100 1987 - 1990	V6 Cil. 4.9 L	E7TZ9A758A	AC45	 912mm

FORD - F150 - LOBO









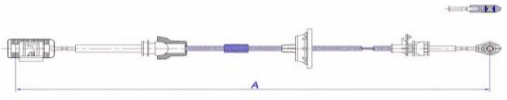

SELECTOR CAMBIOS	2993 FORSC	F-150 T/Automática	0	F75A-7E395-AD	SC48	 1431mm
	4037 FORSC	F-150 2005-2008 T/Automática	V6 Cil. 4.2L 4.6L	5L3Z-7E395-BA	SC103	 1138mm
	4316 FORSC	F-150 2011-2014 T/Automática	3.5L 6.2L	BL3Z7E395C	SC103	 1197mm
	4189 FORSC	F-150 2015-2020 T/Automática	2.7L 3.3L 5.0L	FL3Z-7E395-D	SC128	 1379mm
	2836 FORSC	F-150 Diesel 2001-2007 T/Automática	V8 Cil. 4.6 L 5.4 L	1C3D7E395CB	SC17	 1698mm
	3853 FORSC	F-150 4R75-W 2003-2005 T/Automática	V8 Cil. 4.6 L 5.4 L	4L3Z-7E395-BA	SC82	 1232mm
	3713 FORSC	F-150 2005 - 2008 T/Automática	V8 Cil. 4.6 L 5.4 L	5L3Z-7E395-AA	SC71	 1239mm
	1780 FORSC	F-150 w/E40D 1992... T/Automática	V8 Cil. 4.9 L 5.0 L. 5.8 L	F5T7E395A	SC17	 1391mm
	2994 FORSC	F-150 4R70w 1997-1999 T/Automática	v6 Cil. 4.9 L V8 Cil. 5.8 L 7.3 L	F85Z7E395BA	SC48	 1330mm
	4154 FORSC	F-150 T/Automática	4.6L 5.4L	5L3P7E395BC	SC103	 1137mm
SELECTOR CAMBIOS	4041 FORSC	F-150 2015... T/Automática	V8 Cil. 5.0 L	FL3Z7E395E	SC104	 1155mm
	2995 FORSC	F-150 4R70w 1999-2003 T/Automática	V6 Cil. 4.9 L V8 Cil. 5.8 L 7.3 L V6 Cil. 4.9 L	YL3Z7E395BA	SC48	 1330mm
	1781 FORSC	F-150 1992 - 1996 T/Automática	V8 Cil. 5.8 L 7.3 L	F3TA7E395EA	SC17	 1496mm

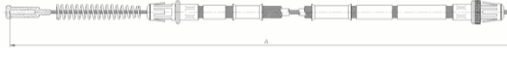
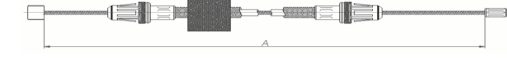
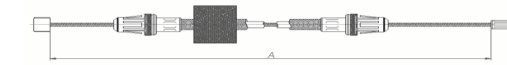
Automóvil - Suv - Van - Pickup - Camiones Pesados - Ligeros

IMPORTANTE. Evite devoluciones o reclamos. Identifique previamente: marca, modelo y año del vehículo. En caso de duda, **CONSULTE** a su asesor.

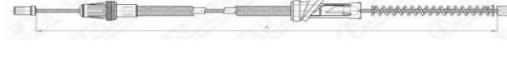
NUESTRA MISIÓN... Ser su aliado en el desarrollo y crecimiento de su negocio

Competimos directamente con los ORIGINALES













LINEA	CODIGO	MODELO	MOTOR	O.E.M	ARMADO	IMAGEN -- LONGITUD
SELECTOR CAMBIOS	4293 FORSC	F-150 Super Duty 2008-2019 T/Automática	0	8C2Z7E395A	SC150	 2058mm
SELECTOR CAMBIOS (Selector)	4022 FORSC	F-150 2004 T/Automática	4.6 L 5.4 L	4L3Z-7E395-CA	SC97	 1125mm
FRENO DE MANO	1706 EFOF	F-150 1992 - 1996 1996 - 1998	V6 Cil. 4.9 L V8 Cil. 5.0 L 5.8 L	F2TZ2853A	FP458 Principal	 1132mm
	2586 FORFP	F-150 Super Cab 1992 - 1996	V6 Cil. 4.9 L V8 Cil. 5.0 L 5.8 L	F2TZ2853A F6TZ2853DA	FP459 Principal	 1130mm
	2623 FORFP	F-150 Super Cab 1996 - 1999	V8 Cil. 5.4 L	F75Z2853AA	FP459 Principal	 1684mm
	4033 FORFP	F-150	0	0	FP214	 2959mm
	4034 FORFP	F-150	0	0	FP214	 1830mm
	4130 FORFP	F-150 1980-1983	0	E07Z-2A635-J E07Z-2A635-A E07Z-2A635-J E1TZ-2A635-E E3TZ-2A635-C	FP243 Trasero Derecho	 2355mm
	4131 FORFP	F-150 1980-1996	0	E8TZ-2A635-B	FP214 Trasero Izquierdo	 1685mm
	4134 FORFP	F-150 1985-1997	0	E7TZ-2A635-E F2TZ-2A635-F F6TZ-2A635-BA	FP261 Trasero Izquierdo	 1500mm
	4136 FORFP	F-150 1980-1994	0	0	FP214 Trasero Derecho	 2500mm
FRENO DE MANO	4137 FORFP	F-150 1984-1991	0	0	FP261 Trasero Derecho	 2344mm
FRENO DE MANO	3707 FORFP	F-150 1985-1999	0	0	FP369 Trasero Izquierdo	 1503mm

Automóvil - Suv - Van - Pickup - Camiones Pesados - Ligeros

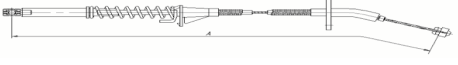
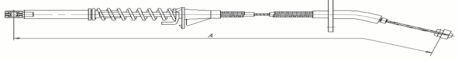
IMPORTANTE. Evite devoluciones o reclamos. Identifique previamente: marca, modelo y año del vehículo. En caso de duda, **CONSULTE** a su asesor.

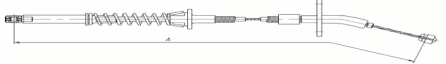
NUESTRA MISIÓN... Ser su aliado en el desarrollo y crecimiento de su negocio

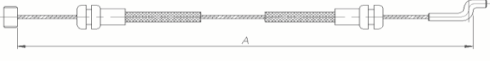
Competimos directamente con los ORIGINALES



LINEA	CODIGO	MODELO	MOTOR	O.E.M	ARMADO	IMAGEN -- LONGITUD
VELOCIMETRO	646 FORVZ	F-150 1980 - 1986	V6 Cil. 4.9 L V8 Cil. 5.0 L 5.8 L	83TK-17260-BA	VZ27	 1996mm
	2703 FORVZ	F-150 1985 - 1997	L4 Cil. 1.3 L	E5UZ9A820A E69Z9A820B	VZ88	 2337mm
SOBREMARCHA	4138 FORSB	F-150 1988-1991	4.9L 5.8L	E6TZ-7A187-D	SB37	 1294mm
ACELERADOR	2231 FORAC	F-150 1989-1993	V6 Cil. 4.9 L V8 Cil. 5.0 L 5.8 L	0	AC42	 1025mm
	2232 FORAC	F-150 1979-1992	V6 Cil. 4.9 L	E0TD9A758AD/AC	AC42	 545mm
	2098 FORAC	F-150 XLT Fuel Inyection 1980-1986	V6 Cil. 4.9 L 2.8 L	D4UZ9A758G	AC42	 1040mm
	1525 EFOA	F-150 Motor 302 - 351W 1985 - 1990	V6 Cil. 4.9 L 2.8 L	E5TZ9A758A	AC45	 1065mm
	399 EFOA	F-150 Motor 302-351M 1981 - 1985	V6 Cil. 4.9 L 2.8 L	E1TZ9A758E	AC45	 568mm
	1442 EFOA	F-150 motor 300 1979-1992	V6 Cil. 4.9 L V8 Cil. 5.0 L 5.8 L	E1TZ9A758D	AC42	 695mm
	2504 FORAC	F-150 1991 - 1993	V8 Cil. 5.0 L 5.8 L	F1TZ9A758K	AC110	 767mm
	2486 FORAC	F-150 Motor 300 1991 - 1996	V6 Cil. 4.9 L 2.8 L	F4TZ9A758M	AC110	 997mm
ACELERADOR	3709 FORAC	F-150	0	1C3D-9A758-AA	AC265	 2266mm
APERTURA CHAPA	236 EFOC	F-150 1992...	V6 Cil. 2.7 L V8 Cil. 4.7 L	F3TZ15221A00A	ACH1Trasero Derecho/Izquierdo	 575mm
	3790 FORAP	Lobo 3a.	V6 Cil. 3.7 L V8 Cil. 4.7 L	0	ACH5 Puerta inferior	 815mm
APERTURA CHAPA	3791 FORAP	Lobo 3a.	V6 Cil. 3.7 L V8 Cil. 4.7 L	0	ACH5 Puerta Superior	 595mm

Automóvil - Suv - Van - Pickup - Camiones Pesados - Ligeros









IMPORTANTE. Evite devoluciones o reclamos. Identifique previamente: marca, modelo y año del vehículo. En caso de duda, **CONSULTE** a su asesor.

NUESTRA MISIÓN... Ser su aliado en el desarrollo y crecimiento de su negocio

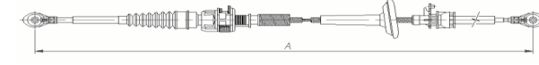
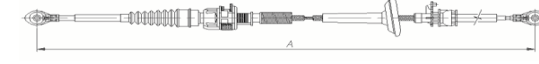
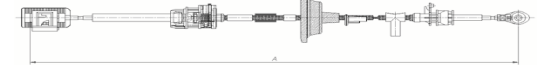
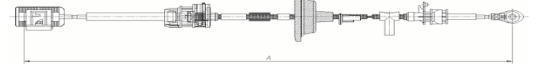
Competimos directamente con los ORIGINALES

LINEA	CODIGO	MODELO	MOTOR	O.E.M	ARMADO	IMAGEN -- LONGITUD
	3789 FORAP	Lobo	V6 Cil. 3.7 L V8 Cil. 4.7 L	0	ACH6	 565mm
SOPORTE CAJUELA	518 EFOC	F-150 todos	V6 Cil. 5.7 L V8 Cil. 4.7 L	E8TZ9943053A	CO3 Lado Izquierdo	 544mm
	517 EFOC	F-150 s todos	V6 Cil. 5.7 L V8 Cil. 4.7 L	E8TZ9943052A	CO2 Lado Derecho	 544mm

FORD - F250









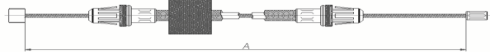
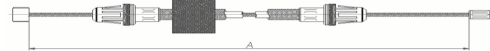

SELECTOR CAMBIOS	4165 FORSC	F-250 2008-2010 T/Automática	V8 5.4L	7C3Z7E395C	SC125	 1360mm
	2993 FORSC	F-250 T/Automática	0	F75A-7E395-AD	SC48	 1431mm
	2836 FORSC	F-250 Diesel 2001- 2007 T/Automática	V8 Cil. 4.6 L 5.4 L	1C3D7E395CB	SC17	 1698mm
	1780 FORSC	F-250 w/E40D Electronic 1992... T/Automática	V8 Cil. 4.9 L 5.0 L 5.8 L	F5TZ7E395A	SC17	 1391mm
	2994 FORSC	F-250 4R70w Transmission 1997-1999 T/Automática	v6 Cil. 4.9 L V8 Cil. 5.8 L 7.3 L	F85Z7E395BA	SC48	 1330mm
	2995 FORSC	F250 4R70w Transmission 1999-2003 T/Automática	V6 Cil. 4.9 L V8 Cil. 5.8 L 7.3 L	YL3Z7E395BA	SC48	 1330mm
	3695 FORSC	F250 1999 T/Automática	v6 Cil. 4.9 L V8 Cil. 5.8 L 7.3 L	XC3Z-7E395AA XC3Z-7E395CA	SC119	 1548mm
	3474 FORSC	F250 Super Duty 1999-2004 T/Automática	v6 Cil. 4.9 L V8 Cil. 5.8 L 7.3 L	XC3Z7E395AA/AB /DA/DB/EA	SC119	 1508mm
	4292 FORSC	F-250 Super Duty 2005-2007 T/Automática	0	5C3Z7E395C	SC125	 1489mm
	4293 FORSC	F-250 Super Duty 2008-2019 T/Automática	0	8C2Z7E395A	SC150	 2058mm
FRENO DE MANO	3424 FORFP	F-250	0	0	LP1	 278mm
FRENO DE MANO	2819 FORFP	F-250 2000 - 2005	V8 Cil. 5.4 L	YC3Z2A635BA	FP263	 1961mm

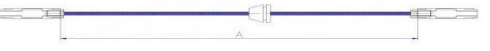
Automóvil - Suv - Van - Pickup - Camiones Pesados - Ligeros

IMPORTANTE. Evite devoluciones o reclamos. Identifique previamente: marca, modelo y año del vehículo. En caso de duda, **CONSULTE** a su asesor.

NUESTRA MISIÓN... Ser su aliado en el desarrollo y crecimiento de su negocio

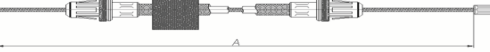
Competimos directamente con los ORIGINALES





LINEA	CODIGO	MODELO	MOTOR	O.E.M	ARMADO	IMAGEN -- LONGITUD
FRENO DE MANO	3000 FORFP	F-250 330 CID SOHC 1999	V6 Cil. 4.9 L V8 Cil. 5.0 L 5.8 L	0	FP240 Principal	 2850mm
	2586 FORFP	F-250 Super Cab 1992 - 1996	V6 Cil. 4.9 L V8 Cil. 5.0 L 5.8 L	F2TZ2853A F6TZ2853DA	FP459 Principal	 1130mm
	2623 FORFP	F-250 Super Cab, 1996 - 1999	V8 Cil. 5.4 L	F75Z2853AA	FP459 Principal	 1684mm
	4080 FORDF	F-250 Super 2005-2007	5.4L	5C3Z2A793JA	FP429	 2190 mm
	4078 FORDF	F-250 Super 2005-2007	5.4L	5C3Z2A793GA	FP429	 1900 mm
	4033 FORFP	F-250	0	0	FP214	 2959mm
	4131 FORFP	F-250 1980-1996	0	E8TZ-2A635-B	FP214 Trasero Izquierdo	 1685mm
	4132 FORFP	F-250 1975-1979	0	D5UZ-2A635-A D7TZ-2A635-H	FP214 Trasero Derecho	 1465mm
	4133 FORFP	F-250 1976-1979	0	D7TZ-2A635-G	FP214 Trasero Izquierdo	 1638mm
	4136 FORFP	F-250 1980-1997	0	0	FP214 Trasero Derecho	 2500mm
	4034 FORFP	F-250	0	0	FP214	 1830mm
	3174 FORFP	F-250 Super Duty (3/4 Ton) 2000	V6 Cil. 4.9 L V8 Cil. 5.0 L 5.8 L	XL3Z2853AA	FP242 Principal	 2336mm
	SOBREMARCHA	4138 FORSB	F-250 1988-1991	4.9L 5.8L	E6TZ-7A187-D	SB37
	2231 FORAC	F-250 1989-1993	V6 Cil. 4.9 L V8 Cil. 5.0 L 5.8 L	0	AC42	 1025mm

Automóvil - Suv - Van - Pickup - Camiones Pesados - Ligeros

IMPORTANTE. Evite devoluciones o reclamos. Identifique previamente: marca, modelo y año del vehículo. En caso de duda, **CONSULTE** a su asesor.

NUESTRA MISIÓN... Ser su aliado en el desarrollo y crecimiento de su negocio



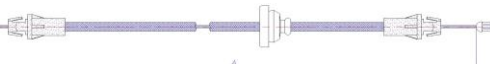

Competimos directamente con los ORIGINALES

LINEA	CODIGO	MODELO	MOTOR	O.E.M	ARMADO	IMAGEN -- LONGITUD
ACELERADOR	1442 EFOA	F-250 Motor 300 1979-1992	V6 Cil. 4.9 L V8 Cil. 5.0 L 5.8 L	E1TZ9A758D	AC42	 695mm
	2504 FORAC	F-250 1991 - 1993 T/Automática	V8 Cil. 5.0 L 5.8 L	F1TZ9A758K	AC110	 767mm
	2486 FORAC	F-250 Motor 300 1991 - 1996 T/Automática	V6 Cil. 4.9 L 2.8 L	F4TZ9A758M	AC110	 997mm
	1629 EFOA	F-250 1992-1994	V6 Cil. 4.9 L V8 Cil. 5.0 L 5.8 L	F1TZ9A758E	AC45	 914mm
ACELERADOR	3709 FORAC	F-250	0	1C3D-9A758-AA	AC265	 2266mm
APERTURA COFRE	3428 FORCA	F-250 Super Duty XL, XLT, Lazo, 2006	V6 Cil. 3.7 L V8 Cil. 4.7 L	5C3Z16916AA	CP27	 2196mm

FORD - F300

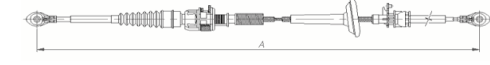
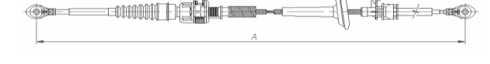
ACELERADOR	2232 FORAC	F-300 1979-1992	V6 Cil. 4.9 L	E0TD9A758AD/AC	AC42	 545mm
------------	---------------	--------------------	------------------	----------------	------	--

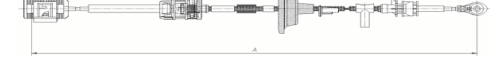
FORD - F300 - F350

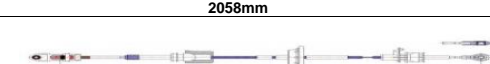
SELECTOR CAMBIOS	4165 FORSC	F-350 Super Duty 2008-2010 T/Automática	V10 6.4L	7C3Z7E395C	SC125	 1360mm
	2836 FORSC	F-350 Diesel 2001- 2007 T/Automática	V8 Cil. 4.6 L 5.4 L	1C3D7E395CB	SC17	 1698mm
	1780 FORSC	F-350 w/E40D Electronic 1992... T/Automática	V8 Cil. 4.9 L 5.0 L 5.8 L	F5TZ7E395A	SC17	 1391mm
	3695 FORSC	F-350 Super Duty 1999 T/Automática	V6 Cil. 4.9 L V8 Cil. 5.8 L 7.3 L	XC3Z-7E395AA XC3Z-7E395CA	SC119	 1548mm
	3474 FORSC	F-350 Super Duty 1999-2004 T/Automática	V6 Cil. 4.9 L V8 Cil. 5.8 L 7.3 L	XC3Z7E395AA/AB /DA/DB/EA	SC119	 1508mm
	4292 FORSC	F-350 Super Duty 2005-2007 T/Automática	0	5C37E395C	SC125	 1489mm
	4293 FORSC	F-350 Super Duty 2008-2019 T/Automática	0	8C2Z7E395A	SC150	 2058mm
	4060 FORSC	F-350 2011-2016 T/Automática	6.8L	DC3Z7E395A	SC106	 1429mm

Encino 1287 col. del Fresno Guadalajara Jal.







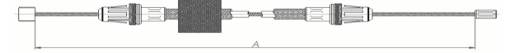
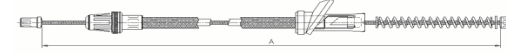

Tel. Multilínea (33) 3811 6917 - Servi Cliente Cel. 33 1992 6768 - Guadalajara, Jalisco
Correo: ventas@flexcontrol.com.mx - www.flexcontrol.com.mx - www.cablesnavcar.com

Automóvil - Suv - Van - Pickup - Camiones Pesados - Ligeros

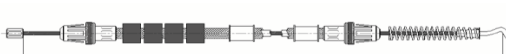
IMPORTANTE. Evite devoluciones o reclamos. Identifique previamente: marca, modelo y año del vehículo. En caso de duda, **CONSULTE** a su asesor.

NUESTRA MISIÓN... Ser su aliado en el desarrollo y crecimiento de su negocio

Competimos directamente con los ORIGINALES

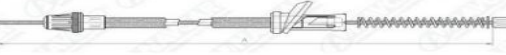
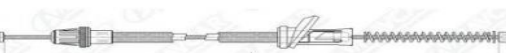
LINEA	CODIGO	MODELO	MOTOR	O.E.M	ARMADO	IMAGEN -- LONGITUD
FRENO DE MANO	1706 EFOF	F-350 1992 - 1998	V6 Cil. 4.9 L V8 Cil. 5.0 L 5.8 L	F2TZ2853A	FP458 Principal	 1132mm
	3999 FORFP	F-350 Super Duty 1998-2008,	V8 Cil. 5.4 L	F81Z2A-635HA	FP242 Principal	 1780mm
FRENO DE MANO	2768 FORFP	F-350 1992 - 1996	V6 Cil. 4.9 L V8 Cil. 5.0 L 5.8 L	F2TZ2A635K	FP214 Trasero Izquierdo	 1689mm
	2767 FORFP	F-350 1992 - 1996	V6 Cil. 4.9 L V8 Cil. 5.0 L 5.8 L	F2TZ2A635J	FP214 Trasero Derecho	 2514mm
	2586 FORFP	F-350 Super Cab 1992 - 1996	V6 Cil. 4.9 L V8 Cil. 5.0 L 5.8 L	F2TZ2853A / F6TZ2853DA	FP459 Principal	 1130mm
	2819 FORFP	F-350 Super Duty 2000 - 2005	V8 Cil. 5.4 L	YC3Z2A635BA	FP263	 1961mm
	636 EFOF	F-350 1980 - 1994	V8 Cil. 5.4 L	F2TZ2A635H	FP66 Trasero Izquierdo	 1600mm
	736 EFOF	F-350 1980 - 1994	V8 Cil. 5.4 L	F2TZ2A635G	FP66 Trasero Derecho	 2420mm
	4079 FORDF	F-350 Super 2005-2007	6.8L	5C3Z2A793FA	FP429	 1825mm
	4080 FORDF	F-350 Super 2005-2007	6.8L	5C3Z2A793JA	FP429	 2190mm
	4033 FORFP	F-350	0	0	FP214	 2959mm
	4034 FORFP	F-350	0	0	FP214	 1830mm
	4131 FORFP	F-350 1980-1996	0	E8TZ-2A635-B	FP214 Trasero Izquierdo	 1685mm
	4136 FORFP	F-350 1980-1997	0	0	FP214 Trasero Derecho	 2500mm













Encino 1287 col. del Fresno Guadalajara Jal.

Automóvil - Suv - Van - Pickup - Camiones Pesados - Ligeros

IMPORTANTE. Evite devoluciones o reclamos. Identifique previamente: marca, modelo y año del vehículo. En caso de duda, **CONSULTE** a su asesor.

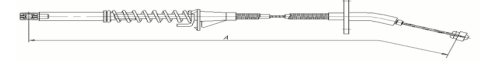
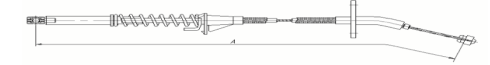
NUESTRA MISIÓN... Ser su aliado en el desarrollo y crecimiento de su negocio

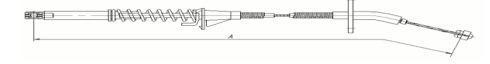
Competimos directamente con los ORIGINALES

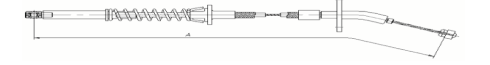

LINEA	CODIGO	MODELO	MOTOR	O.E.M	ARMADO	IMAGEN -- LONGITUD
VELOCIMETRO	647 FORVZ	F-350 1980 - 1986	V6 Cil. 4.9 L V8 Cil. 5.0 L 5.8 L	83TK17260AA	VZ27	 1891mm
	641 FORVZ	F-350 1978-1980	L4 Cil. 1.3 L	D7TA-17260-MA	VZ27	 1665mm
	2703 FORVZ	F-350 1985 - 1997	L4 Cil. 1.3 L	E5UZ9A820A / E69Z9A820B	VZ88	 2337mm
SOBREMARCHA	4138 FORSB	F-350 1988-1991	4.9L 5.8L	E6TZ-7A187-D	SB37	 1294mm
ACELERADOR	397 EFOA	F-350 1983 - 1986	V6 Cil. 4.9 L 2.8 L	E3TZ9A758B	AC42	 780mm
	2231 FORAC	F-350 1989-1993	V6 Cil. 4.9 L V8 Cil. 5.0 L 5.8 L	0	AC42	 1025mm
	1594 EFOA	F-350 1980 - 1982	V8 Cil. 4.9 L	E1TZ9A758C	AC45	 770mm
	2232 FORAC	F-300 / F-350 1979-1992	V6 Cil. 4.9 L	E0TD9A758AD/AC	AC42	 545mm
	1525 EFOA	F-350 Motor 302 - 351W 1985 - 1990	V6 Cil. 4.9 L 2.8 L	E5TZ9A758A	AC45	 1065mm
	399 EFOA	F-350 Motor 302-351M 1981 - 1985	V6 Cil. 4.9 L 2.8 L	E1TZ9A758E	AC45	 568mm
	1629 EFOA	F-350 Custom, Eddie, XL, XLT 1992-2003	V6 Cil. 4.9 L V8 Cil. 5.0 L 5.8 L	F1TZ9A758E	AC45	 914mm
	1441 EFOA	F-350 1992...	V8 Cil. 5.8 L	F4TZ9A758L	AC110	 1083mm
	1526 EFOA	F-350 1987 - 1990	V6 Cil. 4.9 L	E7TZ9A758A	AC45	 912mm
	1442 EFOA	F-350 Motor 300 1979-1992	V6 Cil. 4.9 L V8 Cil. 5.0 L 5.8 L	E1TZ9A758D	AC42	 695mm
	2504 FORAC	F-350 w/E4OD 1991 - 1993 T/Automática	V8 Cil. 5.0 L 5.8 L	F1TZ9A758K	AC110	 1092mm
	2486 FORAC	F-350 300 1991 - 1996 T/Automática	V6 Cil. 4.9 L 2.8 L	F4TZ9A758M	AC110	 997mm

Automóvil - Suv - Van - Pickup - Camiones Pesados - Ligeros





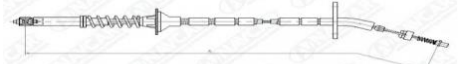

¡IMPORTANTE! Evite devoluciones o reclamos. Identifique previamente: marca, modelo y año del vehículo. En caso de duda, **CONSULTE** a su asesor.

NUESTRA MISIÓN... Ser su aliado en el desarrollo y crecimiento de su negocio

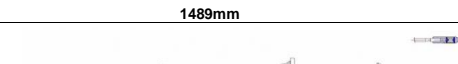

Competimos directamente con los ORIGINALES

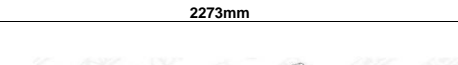
LINEA	CODIGO	MODELO	MOTOR	O.E.M	ARMADO	IMAGEN -- LONGITUD
ACELERADOR	2241 FORAC	F-350 1998-2002	V8 Cil. 5.4 L	F1T29A758AB	AC187	 1319mm
ACELERADOR	3709 FORAC	F-350	0	1C3D-9A758-AA	AC265	 2266mm
APERTURA CHAPA	236 EFOC	F-350 1992...	V6 Cil. 2.7 L V8 Cil. 4.7 L	F3TZ15221A00A	ACH1Trasero Derecho/ Izquierdo	 575mm

FORD - F450 Super Duty

SELECTOR CAMBIOS	3695 FORSC	F-450 Super Duty 1999 T/Automática	V8 Cil. 4.9 L V8 Cil. 5.8 L 7.3 L	XC3Z-7E395AA XC3Z-7E395CA	SC119	 1548mm
	3474 FORSC	F-450 Super Duty 1999-2004 T/Automática	V6 Cil. 4.9 L V8 Cil. 5.8 L 7.3 L	XC3Z7E395AA/AB /DA/DB/EA	SC119	 1508mm
	4292 FORSC	F-450 Super Duty 2005-2007 T/Automática	0	5C3Z7E395C	SC125	 1489mm
	4293 FORSC	F-450 Super Duty 2008-2019 T/Automática	0	8C2Z7E395A	SC150	 2058mm
	4060 FORSC	F-450 2011-2016 T/Automática	6.8L	DC3Z7E395A	SC106	 1429mm
FRENO DE MANO	4103 FORFP	F-450 2003 - 2004	0	3C3Z 2A635-GA 4C3Z 2A635-GA	FP443 Trasero Derecho	 2273mm
	4136 FORFP	F-450 1980-1997	0	0	FP214 Trasero Derecho	 2500mm
APERTURA CHAPA	3784 FORAP	Super Duty Mod. 1999 - 2007	V6 Cil. 3.7 L V8 Cil. 4.7 L	0	ACH2	 527mm

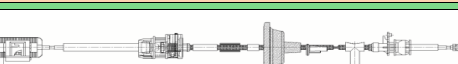
FORD - F550 Super Duty

SELECTOR CAMBIOS	3695 FORSC	F-550 Super Duty 1999 T/Automática	V8 Cil. 4.9 L V8 Cil. 5.8 L 7.3 L	XC3Z-7E395AA XC3Z-7E395CA	SC119	 1548mm
	4060 FORSC	F-550 2011-2016 T/Automática	6.8L	DC3Z7E395A	SC106	 1429mm
	3474 FORSC	F-550 Super Duty 1999-2004 T/Automática	V6 Cil. 4.9 L V8 Cil. 5.8 L 7.3 L	XC3Z7E395AA/AB /DA/DB/EA	SC119	 1508mm

Encino 1287 col. del Fresno Guadalajara Jal.



Tel. Multilínea (33) 3811 6917 - Servi-Cliente Cel. 33 1992 6768 - Guadalajara, Jalisco
Correo: ventas@flexcontrol.com.mx - www.flexcontrol.com.mx - www.cablesnavcar.com

Automóvil - Suv - Van - Pickup - Camiones Pesados - Ligeros



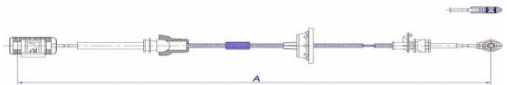

IMPORTANTE. Evite devoluciones o reclamos. Identifique previamente: marca, modelo y año del vehículo. En caso de duda, **CONSULTE** a su asesor.

NUESTRA MISIÓN... Ser su aliado en el desarrollo y crecimiento de su negocio

Competimos directamente con los ORIGINALES

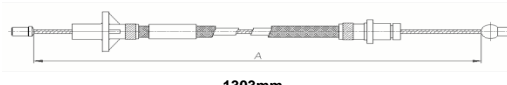
LINEA	CODIGO	MODELO	MOTOR	O.E.M	ARMADO	IMAGEN -- LONGITUD
SELECTOR CAMBIOS	4292 FORSC	F-550 Super Duty 2005-2007 T/Automática	0	5C3Z7E395C	SC125	 1489mm
FRENO DE MANO	4103 FORFP	F-550 2003 - 2004	0	3C3Z 2A635-GA 4C3Z 2A635-GA	FP443 Trasero Derecho	 2273mm



FORD - FAIRMONT

EMBRAGUE	2283 FOREM	Fairmont	V8 Cil. 5.0 L	0	EM98	 1303mm
	2284 FOREM	Fairmont	V8 Cil. 5.0 L	0	EM99	 1479mm
	1710 EFOE	Fairmont 1983	L6 Cil. 3.3 L V8 Cil. 4.2 L	D9BZ7K553F	EM75	 1020mm
	3773 FOREM	Fairmont 1979	V8 Cil. 5.0 L	D9BZ-7K553-D D9ZZ 7K553-B	EM140	 1430mm

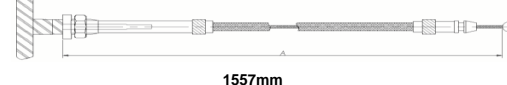
FORD - FESTIVA

EMBRAGUE	949 EFOE	Festiva 1993...	0	8BZTK553A	EM24	 680mm
APERTURA COFRE	2524 FORCA	Festiva todos	V6 Cil. 2.7 L V8 Cil. 4.7 L	0	CP7	 1557mm

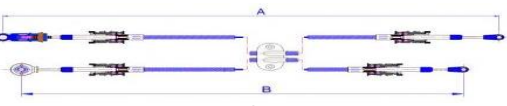
FORD - FIESTA

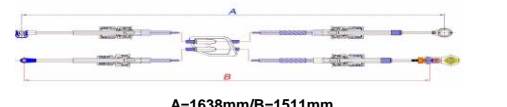
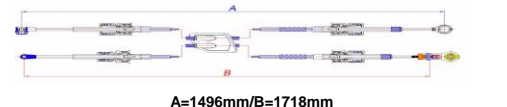
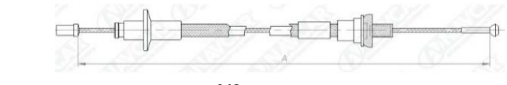





KIT CONTROL Y SELECTOR CAMBIOS	4006 FORCC	Fiesta 2004-2008 T/Standar	2.0 L	2S65-7E395-BA 2S65-7E395-BD 2S65-7E395-BB 2S65-7E395-BE	CC93	 A=1707mm/B=1515mm
KIT CONTROL Y SELECTOR CAMBIOS	4356 FORCC	Fiesta 2014-2019 T/Standar	1.6L	4FTA156FA6NA	CC141	 A=1659mm/B=1565mm
KIT CONTROL Y SELECTOR CAMBIOS	4328 FORCC	Fiesta 2011-2015 T/Standar	1.6L	8A6Z7E395A 8A6R7E395	CC137	 A=1638mm/B=1511mm
KIT CONTROL Y SELECTOR CAMBIOS	4342 FORCC	Fiesta 2010-2015 T/Standar	1.6L	AN157E395CA	CC134	 A=1496mm/B=1718mm
EMBRAGUE	1648 EFOE	Fiesta	0	92FB7K553AA	EM83	 648mm

Automóvil - Suv - Van - Pickup - Camiones Pesados - Ligeros

IMPORTANTE. Evite devoluciones o reclamos. Identifique previamente: marca, modelo y año del vehículo. En caso de duda, **CONSULTE** a su asesor.

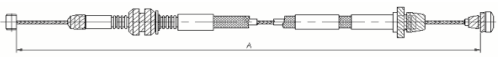
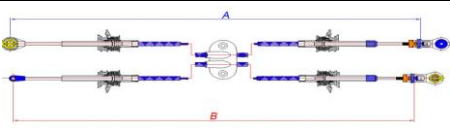
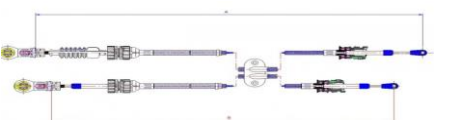
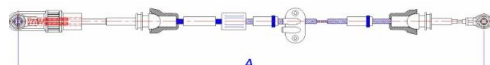
NUESTRA MISIÓN... Ser su aliado en el desarrollo y crecimiento de su negocio

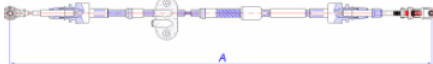
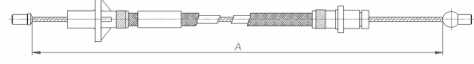
Competimos directamente con los ORIGINALES

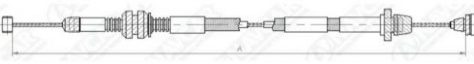
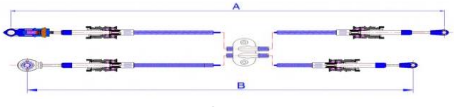
LINEA	CODIGO	MODELO	MOTOR	O.E.M	ARMADO	IMAGEN -- LONGITUD
VELOCIMETRO	1643 FORVZ	Fiesta 1996...	L4 Cil. 1.6 L	96FB17260CC	VZ30	 830mm
ACELERADOR	4039 FORAC	Fiesta 2002...	1.0L	2S65-9C799-AC	AC124	 995mm
	1633 EFOA	Fiesta 1996...	L4 Cil. 1.0 L 1.3 L	96FB9C799JF	AC124	 1840mm
FORD- FIGO						
KIT CONTROL Y SELECTOR CAMBIOS	4240 FORCC	Figo 2013-2017 T/Estándar	1.6L	157E395CA	CC134	 A=1496mm/B=1718mm
FORD- FOCUS						
KIT CONTROL Y SELECTOR CAMBIOS	4251 FORCC	Focus 2003.. T/Estándar	2.0L	2S4R7E395FF	CC121	 A=1229mm/B=1106mm
SELECTOR CAMBIOS	4378 FORSC	Focus 2012-2015 T/Automática	1.0 L	CV6Z7E395E	SC172	 2069mm
APERTURA COFRE	4230 FORCA	Focus 1998 - 2005	2.0L 2.5L	0	CP36	 1985mm
FORD - FUSION						
SELECTOR CAMBIOS	4374 FORSC	Fusion 2014 - 2016	1.6 L	DG9Z7E395AY	SC166	 1615mm
FORD - GRANADA						
EMBRAGUE	2283 FOREM	Granada	V8 Cil. 5.0 L	0	EM98	 1303mm
	1710 EFOE	Granada 1981-1982	L6 Cil. 3.3 L V8 Cil. 4.2 L	D9BZ7K553F	EM75	 1020mm
FORD - IKON						
ACELERADOR	4039 FORAC	Ikon 2000-2007	1.6L	2S65-9C799-A	AC124	 995mm
KIT SELECTOR CAMBIOS	4006 FORCC	Ikon 2010-2012 T/Standar	2.0L	2S65-7E395-BA 2S65-7E395-BD 2S65-7E395-BB 2S65-7E395-BE	CC93	 A=1707mm/B=1551mm

Encino 1287 col. del Fresno Guadalajara Jal.











Tel. Multilínea (33) 3811 6917 - Serv. Cliente Cel. 33 1992 6768 - Guadalajara, Jalisco
Correo: ventas@flexcontrol.com.mx - www.flexcontrol.com.mx - www.cablesnavcar.com

Automóvil - Suv - Van - Pickup - Camiones Pesados - Ligeros

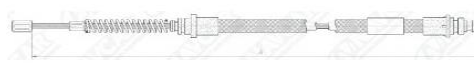
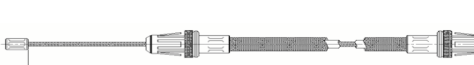
IMPORTANTE. Evite devoluciones o reclamos. Identifique previamente: marca, modelo y año del vehículo. En caso de duda, **CONSULTE** a su asesor.

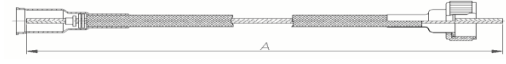
NUESTRA MISIÓN... Ser su aliado en el desarrollo y crecimiento de su negocio

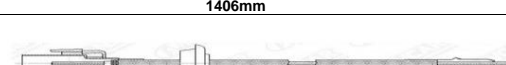
Competimos directamente con los ORIGINALES

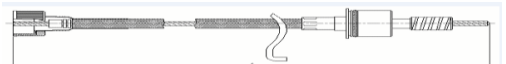
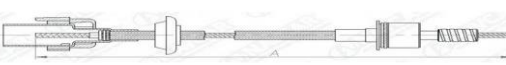
LINEA	CODIGO	MODELO	MOTOR	O.E.M	ARMADO	IMAGEN -- LONGITUD
FORD - LINCOLN						
SELECTOR CAMBIOS	3713 FORSC	Lincoln Mark LT 2005 - 2008 T/Automática	V8 Cil. 4.6 L 5.4 L	5L3Z-7E395-AA	SC71	 1239mm
	4037 FORSC	Lincoln Mark 2010-2014 T/Automática	V8 Cil. 5.3 L	5L3Z-7E395-BA	SC103	 1138mm
EMBRAGUE	1711 EFOE	Lincoln 1982 - 1986	5.0L V8	E4ZC7K553A	EM77	 1463mm
FRENO DE MANO	3073 FORFP	Lincoln Town car 1998-2002	V8-4.6L	2W1Z-2A635-FA	FP239 Trasero Izquierdo	 2195mm
	3172 FORFP	Lincoln Marck IV, V 1975 - 1979	V8 Cil 6.6L 7.5L	D5SZ-2853-A D6SZ-2853-A D8LY-2853-A	FP36 Principal	 1234mm
	2760 FORFP	Lincoln Mark Series VIII LSC 1993 - 1998	V8 Cil. 4.6 L	F3SZ2853A	FP240 Principal	 751mm
	2826 FORFP	Lincoln 2003 - 2004	V8 Cil. 4.6 L	0	FP459 Principal	 1400mm
VELOCIMETRO	2539 FORVZ	Lincoln 1965-1986	V8 Cil. 4.6 L	C5TZ17260N E4TZ17260N	VZ79	 1727mm
	2702 FORVZ	Lincoln 1983 - 1997	V8 Cil. 4.6 L	E3TZ9A820B F58Z9A820A	VZ88 Tramo Superior	 1406mm
	2701 FORVZ	Lincoln 1980 - 1998	V8 Cil. 4.6 L	E6DZ9A820A	VZ88 Tramo Superior	 940mm
VELOCIMETRO	2700 FORVZ	Lincoln Town Car 4WD RWD 1983 - 1998	V8 Cil. 4.6 L	E3BZ9A820A	VZ88	 1854mm
ACELERADOR	396 EFOA	Lincoln Motor 302 1980	V8 Cil. 4.9 L	E0AZ9A758A	AC42	 750mm
FORD - LTD						
VELOCIMETRO	3052 FORVZ	LTD 1960-1981	0	B9MF17260-B C0MF17260-A C6DZ17260-B	VZ84	 1707mm
	2165 FORVU	LTD C6 W/O Cruise 1969	V6 Cil.	D4ZZ17260A	VZ81	 1986mm

Encino 1287 col. del Fresno Guadalajara Jal.











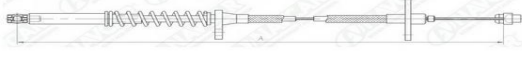

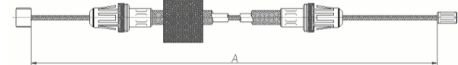
Tel. Multilínea (33) 3811 6917 - Servi-Cliente Cel. 33 1992 6768 - Guadalajara, Jalisco
Correo: ventas@flexcontrol.com.mx - www.flexcontrol.com.mx - www.cablesnavcar.com

Automóvil - Suv - Van - Pickup - Camiones Pesados - Ligeros

IMPORTANTE. Evite devoluciones o reclamos. Identifique previamente: marca, modelo y año del vehículo. En caso de duda, **CONSULTE** a su asesor.

NUESTRA MISIÓN... Ser su aliado en el desarrollo y crecimiento de su negocio

Competimos directamente con los ORIGINALES

LINEA	CODIGO	MODELO	MOTOR	O.E.M	ARMADO	IMAGEN -- LONGITUD
	638 FORVZ	LTD 1979 - 1981	V6 Cil.	D9AF17260AB	VZ32	 1791mm
ACCELERADOR	3606 FORAC	LTD 1983-1989	V8 Cil. 5.0 L	E2SZ-9A758-C	AC43	 487mm
	396 EFOA	LTD Motor 302-351 1979-1980	V8 Cil. 4.9 L	E0AZ9A758A	AC42	 750mm
FORD - MARAUDER						
FRENO DE MANO	2826 FORFP	Marauder 2003 - 2004	V8 Cil. 4.6 L	0	FP459 Principal	 1400mm
FORD - MICROBUS						
ACCELERADOR	1442 EFOA	Microbus 1979-1992	V6 Cil. 4.9 L V8 Cil. 5.0 L 5.8 L	E1TZ9A758D	AC42	 695mm
	2231 FORAC	Microbus 1989-1993	V6 Cil. 4.9 L V8 Cil. 5.0 L 5.8 L	0	AC42	 1025mm
FORD - MUSTANG						
SELECTOR CAMBIOS	3168 FORSC	Mustang LX, GT 1984-1993 T/Automática	V8 Cil. 5.0 L	E4ZZ-7E395A E6ZZ-7E395A	SC64	 1395mm
SELECTOR CAMBIOS	4295 FORSC	Mustang 1999-2004 T Automatica	0	XR3Z-7E395-AA	SC152	 1390mm
EMBRAGUE	1711 EFOE	Mustang 1982 - 1993	5.0L V8	E4ZC7K553A	EM77	 1463mm
	1710 EFOE	Mustang 1979-1984	L6 Cil. 3.3 L V8 Cil. 4.2 L	D9BZ7K553F	EM75	 1020mm
	2635 FOREM	Mustang 1983-1993	L4 Cil. 2.0 L	E6ZZ7535A	EM121	 39mm
	3138 FOREM	Mustang 1996-2003	V6 Cil. 3.8 L	76ZZ7535BA XR3Z7K553AA	EM77	 1545mm
	1712 EFOE	Mustang 1983-1989	L4 Cil. 2.3 L	E3SZ7K553B	EM77	 1500mm
	1836 FOREM	Mustang 1979 - 1985	V6 Cil. 4.0 L V8 Cil. 5.0 L	0	EM87 Cable Ajustable	 1600mm

Encino 1287 col. del Fresno Guadalajara Jal.







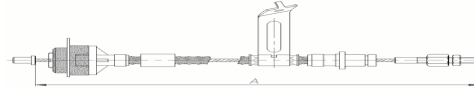

Tel. Multilínea (33) 3811 6917 - Servi-Cliente Cel. 33 1992 6768 - Guadalajara, Jalisco
Correo: ventas@flexcontrol.com.mx - www.flexcontrol.com.mx - www.cablesnavcar.com

Automóvil - Suv - Van - Pickup - Camiones Pesados - Ligeros

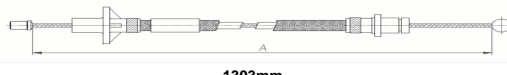
IMPORTANTE. Evite devoluciones o reclamos. Identifique previamente: marca, modelo y año del vehículo. En caso de duda, **CONSULTE** a su asesor.

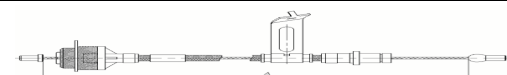
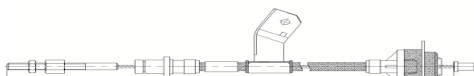
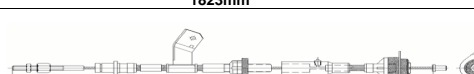
NUESTRA MISIÓN... Ser su aliado en el desarrollo y crecimiento de su negocio

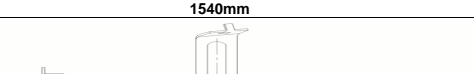
Competimos directamente con los ORIGINALES

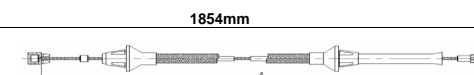
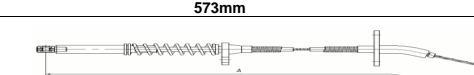
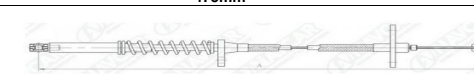
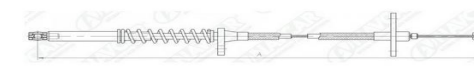
LINEA	CODIGO	MODELO	MOTOR	O.E.M	ARMADO	IMAGEN -- LONGITUD
EMBRAGUE	1764 FOREM	Mustang 1979 - 1995	V6 Cil. 4.0 L V8 Cil. 5.0 L	E4ZZ7K553A E2ZZ7K553C	EM80 Cable Ajustable	 1600mm
	3773 FOREM	Mustang 1979	V8 Cil. 5.0 L	D9BZ-7K553-D D9ZZ 7K553-B	EM140	 1430mm
	2283 FOREM	Mustang	V8 Cil. 5.0 L	0	EM98	 1303mm
	2284 FOREM	Mustang	V8 Cil. 5.0 L	0	EM99	 1479mm
	1838 FOREM	Mustang 1996 - 2003	V6 Cil. 4.0 L V8 Cil. 5.0 L	XR3Z7535CA	EM82	 1756mm
	1765 FOREM	Mustang GT 1996 - 2003	0	XR3Z7K553BA F7ZZ7K553AA F6ZZ7535AA	EM82 Cable Ajustable	 1823mm
	1835 FOREM	Mustang GT 1996 - 2003	0	XR3Z7K553BA F7ZZ7K553AA F6ZZ7535AA	EM86 Cable Ajustable	 1823mm
	1731 FORE	Mustang 1992 - 1995	V6 Cil. 4.0 L V8 Cil. 5.0 L	F4ZZ7K553A	EM77	 1540mm
EMBRAGUE	1769 FOREM	Mustang	V6 Cil. 4.0 L V8 Cil. 5.0 L	0	EM81 Cable Ajustable	 1539mm
VELOCIMETRO	2700 FORVZ	Mustang Traccion 4x4 1983 - 1998	V8 Cil. 4.6 L	E3BZ9A820A	VZ88	 1854mm
ACCELERADOR	1812 FORAC	Mustang 1968 - 1969	V8 Cil. 4.7 L	C9ZZ9A758A	AC79	 573mm
	471 EFOA	Mustang 1982 - 1985	0	E5DZ9A758C	AC42	 475mm
	3605 FORAC	Mustang 1986-1993	V8 Cil. 5.0 L	E6SZ-9A758-A	AC43	 913mm
	3606 FORAC	Mustang 1983-1989	V8 Cil. 5.0 L	E2SZ-9A758-C	AC43	 487mm











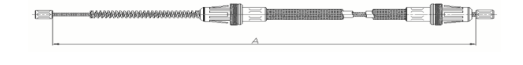

FORD - PINTO

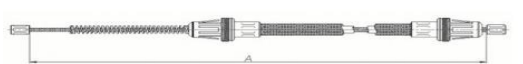
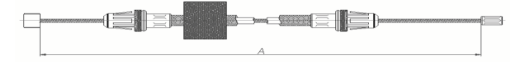
Automóvil - Suv - Van - Pickup - Camiones Pesados - Ligeros

IMPORTANTE. Evite devoluciones o reclamos. Identifique previamente: marca, modelo y año del vehículo. En caso de duda, **CONSULTE** a su asesor.

NUESTRA MISIÓN... Ser su aliado en el desarrollo y crecimiento de su negocio

Competimos directamente con los ORIGINALES

LINEA	CODIGO	MODELO	MOTOR	O.E.M	ARMADO	IMAGEN -- LONGITUD
EMBRAGUE	2283 FOREM	Pinto	V8 Cil. 5.0 L	0	EM98	 1303mm
FORD - RANGER						
SELECTOR CAMBIOS	4044 FORSC	Ranger 2005... T/Automática	V6 Cil. 2.3L	5L5Z-7E395-A	SC105	 1293mm
	3384 FORSC	Ranger 1998-2001 Ranger 1997-2003	V6 Cil. 4.0 L V8 Cil. 4.6 L	F77Z7E395LB	SC17	 1294mm
FRENO DE MANO	2731 FORFP	Ranger 2003 - 2007	V6 Cil. 2.3 L 3.0 L 4.0 L	3L5Z2A635AB	FP239Trasero Derecho/ Izquierdo	 1044mm
	2878 FORFP	Ranger 2004-2011	V6 Cil. 3.0L 4.0 L	5L55-2A635-AB	FP407 Trasero Derecho	 2252mm
	4014 FORFP	Ranger 1999-2004	V6 Cil. 2.3 L	F87Z-2A635CA	FP239 Trasero Izquierdo	 1390mm
FRENO DE MANO	2585 FORFP	Ranger Super 1993 - 1994	V6 Cil. 4.0 L	F37Z2853B	FP242 Principal	 2197mm
	2627 FORFP	Ranger Super 1995 - 1997	V6 Cil. 4.0 L	F57Z2853B	FP459 Principal	 1920mm
VELOCIMETRO	2702 FORVZ	Ranger 1983 - 1997	V8 Cil. 4.6 L	E3TZ9A820B F58Z9A820A	VZ88 Tramo Superior	 1406mm
	2541 FORVZ	Ranger 1983 - 1990		E3TZ17260C D6DZ17260A	VZ85	 1554mm
	2700 FORVZ	Ranger Traccion trasera 4x4 1983 - 1998	V8 Cil. 4.6 L	E3BZ9A820A	VZ88	 1854mm
ACFI FRADOR	2238 FORAC	Ranger 1984-1988	L4 Cil. 2.3 L	0	AC180	 864mm
	2237 FORAC	Ranger Carburador 1984	V6 Cil. 4.9 L 2.8 L	0	AC180	 434mm
	1525 EFOA	Ranger Motor 122 1987-1990	V6 Cil. 4.9 L 2.8 L	E5TZ9A758A	AC45	 1065mm

Encino 1287 col. del Fresno Guadalajara Jal.









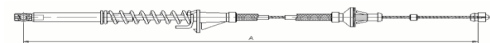

Tel. Multilinea (33) 3811 6917 - Servi-Cliente Cel. 33 1992 6768 - Guadalajara, Jalisco
Correo: ventas@flexcontrol.com.mx - www.flexcontrol.com.mx - www.cablesnavcar.com

Automóvil - Suv - Van - Pickup - Camiones Pesados - Ligeros

IMPORTANTE. Evite devoluciones o reclamos. Identifique previamente: marca, modelo y año del vehículo. En caso de duda, **CONSULTE** a su asesor.

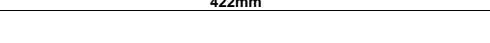
NUESTRA MISIÓN... Ser su aliado en el desarrollo y crecimiento de su negocio

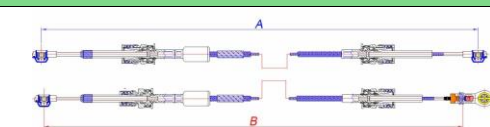
Competimos directamente con los ORIGINALES

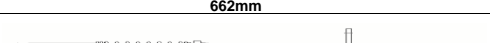

LINEA	CODIGO	MODELO	MOTOR	O.E.M	ARMADO	IMAGEN -- LONGITUD
ACCELERADOR	1596 EFOA	Ranger 1983 - 1989	L4 Cil. 2.2 L 2.3 L	E3TZ9A758E	AC123	 898mm
	2244 FORAC	Ranger 1988-1992	L6 Cil. 4.9 L	0	AC180	 753mm
	2237 FORAC	Ranger Carburado 1984	V6	0	AC180	 434mm
SOBREMARCHA	4138 FORSB	Ranger	0	E6TZ7A187D	SB37	 1294mm
APERTURA CHAPA	3781 FORAP	Ranger 1993-2007	V6 Cil. 3.7 L V8 Cil. 4.7 L	0	ACH6	 616mm
SOPORTE CAJUELA	520 EFOC	Ranger 1997...	V6 Cil. 5.7 L V8 Cil. 4.7 L	F37Z9943053A	CO3 Izquierdo	 422mm
SOPORTE CAJUELA	519 EFOC	Ranger 1997...	V6 Cil. 5.7 L V8 Cil. 4.7 L	F37Z9943052A	CO2 Derecho	 422mm
SOPORTE CAJUELA	4209 FORSO	Ranger 1983-1992	0	E4TZ9843052-A	CO7 Derecho/Izquierdo	 404mm
FORD - TEMPO						
ACCELERADOR	1590 EFOA	Tempo 1981 - 1990	V6 Cil. 1.6 L 1.9 L 2.0 L 2.3 L 2.5 L	E2FZ9A758A	AC42	 1166mm
FORD - TRANSIT						
KIT CONTROL Y SELECTOR CAMBIOS	4347 FORCC	Transit 2007-2015	0	1753358	CC138	 A=1161mm/B=1107mm
FORD - TOPAZ						
EMBRAGUE	2280 FOREM	Topaz 1983-1986	0	0	EM71 Ref Tubo Int Nylon	 645mm
	2281 FOREM	Topaz 1981-1990	L4 Cil. 2.0 L	E3FZ7K553A/B	EM71	 662mm
	1590 EFOA	Topaz 1981 - 1987	V6 Cil. 1.6 L 1.9 L 2.0 L 2.3 L 2.5 L	E2FZ9A758A	AC42	 1166mm

Automóvil - Suv - Van - Pickup - Camiones Pesados - Ligeros



IMPORTANTE. Evite devoluciones o reclamos. Identifique previamente: marca, modelo y año del vehículo. En caso de duda, **CONSULTE** a su asesor.

NUUESTRA MISIÓN... Ser su aliado en el desarrollo y crecimiento de su negocio

Competimos directamente con los ORIGINALES

LINEA	CODIGO	MODELO	MOTOR	O.E.M	ARMADO	IMAGEN -- LONGITUD
ACELERADOR	2235 FORAC	Topaz 1989-1992	L4 Cil. 2.3 L	0	AC180	 615mm
	2233 FORAC	Topaz ...1988	L4 Cil. 2.3 L	863Y9A7588AA	AC180	 450mm
	2242 FORAC	Topaz Fuel Injection 1992	L4 Cil. 2.3 L	0	AC180	 555mm

FORD -TAURUS

SELECTOR CAMBIOS	4067 FORSC	Taurus 1996... T/Automática	0	4F1Z-7E395-AA	SC110	 1067mm
SELECTOR CAMBIOS	3983 FORSC	Taurus SE, SELE 1999-2007 T/Automática	3.0L	2F1Z7E395AA	SC90	 1426mm



FORD-THUNDERBIRD

FRENO DE MANO	3172 FORFP	Thunderbird 1975 - 1979	6.6L 7.5L	D5SZ-2853-A D6SZ-2853-A D8LY-2853-A	FP36 Principal	 1234mm
---------------	----------------------	----------------------------	--------------	---	-------------------	--

FORD - TRACER

VELOCIMETRO	3053 FORVZ	Tracer WO/Cruise 1988-1997	L4 Cil. 1.3 L	E7GZ17260A F4BZ17260B	VZ78 Tramo Inferior	 295mm
-------------	----------------------	----------------------------------	------------------	--------------------------	---------------------------	---

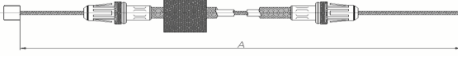
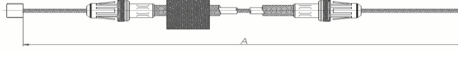
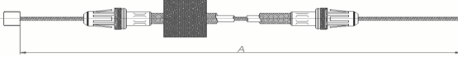
FORD - Truck Series F

FRENO DE MANO	3049 FORFP	Supa F Series	0	2C302780AA	FP461 Principal (39")	 975mm
	3050 FORFP	Supa F Series	0	0	FP461 Principal (47")	 1172mm
	3051 FORFP	Supa F Series	0	0	FP242 Principal (55")	 1375mm
VELOCIMETRO	2539 FORVZ	Camioneta 1965-1986	V8 Cil. 4.6 L	C5TZ17260N E4TZ17260N	VZ79	 1727mm

FORD - UNIVERSAL

VELOCIMETRO	2167 FORVU	Universal 1955 - 1986	0	E1T29A820B	VZ82	 1524mm
-------------	----------------------	--------------------------	---	------------	------	--

FORD - WINDSTAR





SELECTOR CAMBIOS	1783 FORSC	Windstar E40D 1992-1996 T/Automática	V8 Cil. 4.9 L 5.0 L 5.8 L	F2UZ7E395A	SC17	 1855mm
------------------	----------------------	---	------------------------------------	------------	------	--

Automóvil - Suv - Van - Pickup - Camiones Pesados - Ligeros

IMPORTANTE. Evite devoluciones o reclamos. Identifique previamente: marca, modelo y año del vehículo. En caso de duda, **CONSULTE** a su asesor.

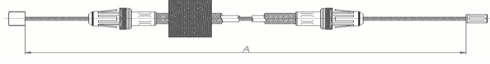

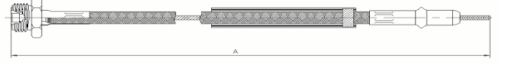
NUESTRA MISIÓN... Ser su aliado en el desarrollo y crecimiento de su negocio

Competimos directamente con los ORIGINALES

LINEA	CODIGO	MODELO	MOTOR	O.E.M	ARMADO	IMAGEN -- LONGITUD
FRENO DE MANO	2619 FORFP	Windstar 1999 - 2003	V6 Cil. 3.0 L 3.8 L	XF2Z2A635AA YF2Z2A635AA	FP242 Trasero Derecho	 1750mm
VELOCIMETRO	2702 FORVZ	Windstar 1983 - 1997	V8 Cil. 4.6 L	E3TZ9A820B F58Z9A820A	VZ88 Tramo Superior	 1406mm
	2842 FORVZ	Windstar 1991-1998	V6 Cil. 3.0 L 3.8 L	F0DZ9F714A	VZ93 Tramo Inferior	 504mm
APERTURA CHAPA	3782 FORAP	Windstar	V6 Cil. 3.7 L V8 Cil. 4.7 L	0	ACH6	 642mm

FOTON

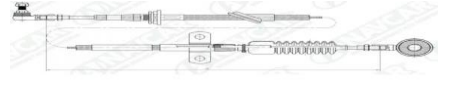

FOTON - AUMAN 12000

CONTROL CAMBIOS (Transversal)	3862 FOTCC	Auman 12000 2013 - 2016 T/Estándar	L4 Cil. 3.8 L	1113317200002	CC61	 3140mm
SELECTOR CAMBIOS (Selector)	3863 FOTSC	Auman 12000 2013 - 2016 T/Standar	L4 Cil. 3.8 L	11133 172 00003	SC84	 3164mm

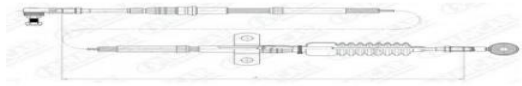
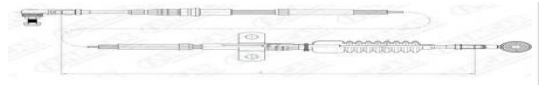
FOTON - C03 C04 C05 C06

CONTROL CAMBIOS (Transversal)	3868 FOTCC	Foton CO5 - CO6 1997....	0	1105917200034	CC54	 3137mm
	3870 FOTCC	Foton CO4 CO6 2011 -2016	0	1106917200012	CC54	 3045mm

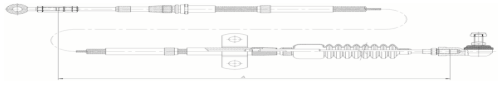
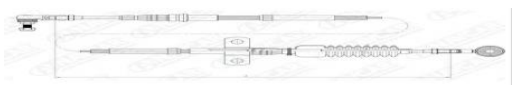
FOTON - 1069

SELECTOR CAMBIOS (Selector)	3126 FOTSC	Olin 1069 4.5 Ton. T/Standar	V8 Cil. 4.5 L 5.6 L	1106917200013	SC41	 3187mm
CONTROL CAMBIOS (Transversal)	3870 FOTCC	Olin 1069 2008 T/Estándar	0	1106917200012	CC54	 3045mm
ACELERADOR	3905 FOTAC	Camión Aumark CO4 2008...	0	7701023771498	AC273	 2391mm

FOTON - 2000 - 3000







SELECTOR CAMBIOS (Selector)	4065 FOTSC	AUMARK 3.000 T/Estándar	0	110591720003	SC109	 3015mm
-----------------------------------	----------------------	----------------------------	---	--------------	-------	--

Automóvil - Suv - Van - Pickup - Camiones Pesados - Ligeros

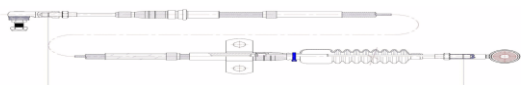
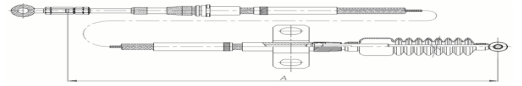
IMPORTANTE. Evite devoluciones o reclamos. Identifique previamente: marca, modelo y año del vehículo. En caso de duda, **CONSULTE** a su asesor.

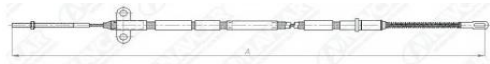
NUESTRA MISIÓN... Ser su aliado en el desarrollo y crecimiento de su negocio

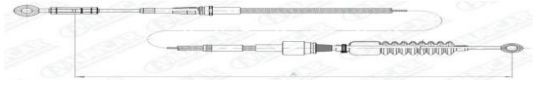
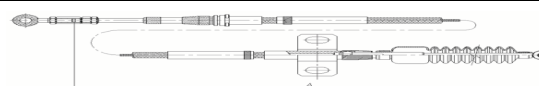
Competimos directamente con los ORIGINALES

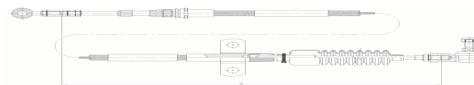
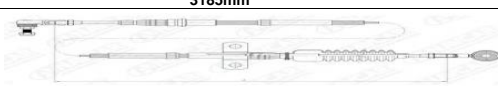
LINEA	CODIGO	MODELO	MOTOR	O.E.M	ARMADO	IMAGEN -- LONGITUD
FRENO DE MANO	3859 FOTFP	2000 y 3000 Cummins 2013-2016	L4 Cil. 3.8 L	11039 3580 0014	FP389	 3603mm
FOTON - 5000 - 6000 - 7000						
CONTROL CAMBIOS (Transversal)	3680M FOTCC	5000, 6000, 7000 Cummins T/Standar	V8 Cil. 3.8 L	1108917200021	CC54	 3142mm
SELECTOR CAMBIOS (Selector)	3681 FOTSC	5000, 6000, 7000 Cummins T/Standar	V8 Cil. 3.8 L	1108917200022	SC39	 3213mm
FRENO DE MANO	3876 FOTFP	5000 2013 - 2016	L4 Cil. 3.8 L	11059 3580 0007	FP389	 3915mm
FOTON - CF-03						
FRENO DE MANO	3865 FOTFP	Foton CF-03 2011...	0	1105335800002	FP171	 3680mm
FOTON - CF2800						
SELECTOR CAMBIOS (Selector)	3127 FOTSC	CF2800 2008 T/Standar	0	7701023665421 1105317200017	SC44	 2801mm
FOTON - FORLAND						
SELECTOR CAMBIOS (Selector)	3882 FOTSC	Forland 2007 T/Standar	3.2L	7.70102E+12	SC66	 2638mm
SELECTOR CAMBIOS (Selector)	3128 FOTSC	Forland 2008 T/Standar	0	1105317200016	SC39	 2693mm
FOTON - OLIN						
CONTROL CAMBIOS (Transversal)	3132 FOTCC	Olin 1069 T/Standar	V8 Cil. 4.5 L 5.6 L	7701023683968 1106917200013	SC44	 3041mm
SELECTOR CAMBIOS (Selector)	3133 FOTSN	Olin 1069 CO 4-6 2088 T/Standar	V8 Cil. 4.5 L 5.6 L	77101023683951	SN6	 3185mm
CONTROL CAMBIOS (Transversal)	3870 FOTCC	Olin 1069 2008 T/Estándar	0	110691720012	CC54	 3045mm
FOTON						
FOTON - (UNIVERSAL)						

Automóvil - Suv - Van - Pickup - Camiones Pesados - Ligeros

IMPORTANTE. Evite devoluciones o reclamos. Identifique previamente: marca, modelo y año del vehículo. En caso de duda, **CONSULTE** a su asesor.





NUESTRA MISIÓN... Ser su aliado en el desarrollo y crecimiento de su negocio

Competimos directamente con los ORIGINALES



LINEA	CODIGO	MODELO	MOTOR	O.E.M	ARMADO	IMAGEN -- LONGITUD
SEGURO TAPA TANQUE (Universal)	4321 FOTTA	Foton	0	0	TC4	

FIAT



FIAT - UNO

EMBRAGUE	4020 FIAEM	Uno Way / Sporting 2011...	1.4 L	55222302 55248414	EM152 Ref Tubo Int Nylon	 708mm
	2658 FIAEM	Uno Fire Duna, Uno, Premio 2005	1.3L	50017546	EM119	 705mm
FRENO DE MANO	4146 FIAFP	Fiat Uno Way 2011...	1.4L	51833540	FP456 Trasero Izquierdo	 1412mm
	4147 FIAFP	Fiat Uno Way 2011...	1.4L	51833538	FP456 Trasero Derecho	 1409mm



FIAT - PALIO

CONTROL CAMBIOS (Transversal)	3875 FIACC	Palio 2001... T/Estándar	1.0L 1.4L 1.5L	46800220 55261730	CC63	 975mm
SELECTOR CAMBIOS (Selector)	3896 FIASC	Palio 2001... T/Estándar	1.0L 1.4L 1.5L	46800221 55270519	SC112	 1070mm

FIAT - SIENA

CONTROL CAMBIOS (Transversal)	3875 FIACC	Siena 2001... T/Estándar	1.0L 1.4L 1.5L	46800220 55261730	CC63	 975mm
SELECTOR CAMBIOS (Selector)	3896 FIASC	Siena 2001... T/Estándar	1.0L 1.4L 1.5L	46800221 55270519	SC112	 1070mm

FIAT - STRADA

CONTROL CAMBIOS (Transversal)	3875 FIACC	Strada 2001... T/Estándar	1.0L 1.4L 1.5L	46800220 55261730	CC63	 975mm
SELECTOR CAMBIOS (Selector)	3896 FIASC	Strada 2001... T/Estándar	1.0L 1.4L 1.5L	46800221 55270519	SC112	 1070mm

GEO / ISUZU



GEO / ISUZU - STORM

Automóvil - Suv - Van - Pickup - Camiones Pesados - Ligeros

IMPORTANTE. Evite devoluciones o reclamos. Identifique previamente: marca, modelo y año del vehículo. En caso de duda, **CONSULTE** a su asesor.

NUESTRA MISIÓN... Ser su aliado en el desarrollo y crecimiento de su negocio

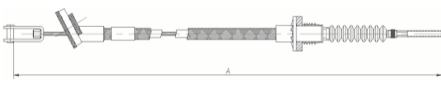
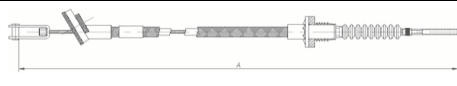
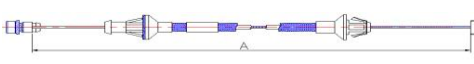
Competimos directamente con los ORIGINALES

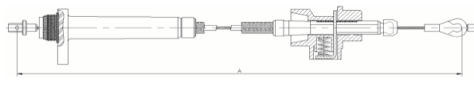
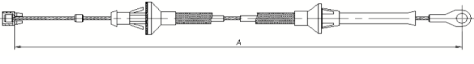
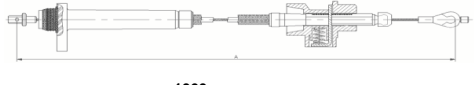
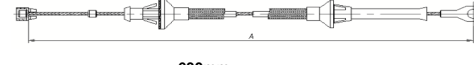
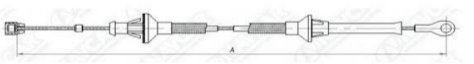

LINEA	CODIGO	MODELO	MOTOR	O.E.M	ARMADO	IMAGEN -- LONGITUD
EMBRAGUE	3419 GEOEM	Storm 1990-1993	L4 Cil. 1.6 L 1.8 L	8944675714	EM130	 900mm
GEO / METRO						
EMBRAGUE	3113 GEOEM	Metro LSI, XFI, 1989-2001	L3 Cil. 1.0 L	30015827	EM12	 553mm
	349 SWIE	Metro 1998...	L4 Cil. 1.3 L	2371063B10 30015828	EM12	 591mm
GMC						
GMC - ALERO						
ACELERADOR	3560 GMCAC	Alero 1997-2004	V6 Cil. 3.4 L	22619741	AC258	 1427mm
GMC - BRAVADA						
SOBREMARCHA	2040 GMC5B	Bravada Traccion 2R Traccion 4x4 1991	0	10111682	SB2	 1028mm
ACELERADOR	3443 GMCAC	Bravada Traccion 2R, Traccion 4x4 1996 - 1997	V6 Cil. 4.1 L	15733071	AC116	 1051mm
GMC - C15						
SOBREMARCHA	840 CHSB	C15 TH700 1985-1986	0	25515598	SB2	 1060mm
ACELERADOR	1519 GMCA	C15 Suburban 1978	V6 Cil. V8 Cil.	25515839	AC1	 630mm
GMC - C25						
SOBREMARCHA	840 CHSB	C25 TH700 1985-1986	0	25515598	SB2	 1060mm
ACELERADOR	1519 GMCA	C25 Suburban 1978	V6 Cil. V8 Cil.	25515839	AC1	 630mm
GMC - C35						
ACELERADOR	1519 GMCA	C35 1978	V6 Cil. V8 Cil.	25515839	AC1	 630mm
GMC - C1500						

Automóvil - Suv - Van - Pickup - Camiones Pesados - Ligeros



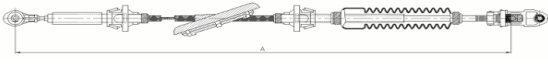

¡IMPORTANTE! Evite devoluciones o reclamos. Identifique previamente: marca, modelo y año del vehículo. En caso de duda, **CONSULTE** a su asesor.

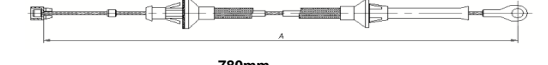
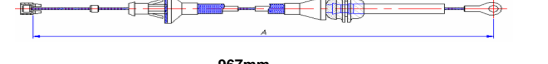
NUESTRA MISIÓN... Ser su aliado en el desarrollo y crecimiento de su negocio



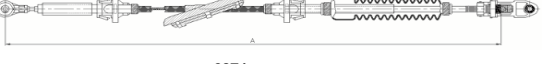

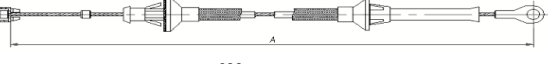
Competimos directamente con los ORIGINALES

LINEA	CODIGO	MODELO	MOTOR	O.E.M	ARMADO	IMAGEN -- LONGITUD
SELECTOR CAMBIOS	2914 GMSCC	C-1500 Traccion 2R 1995-2002 T/Automática	V6 Cil. 4.3 L	15037353	SC46	 2874mm
	4009 GMSCC	C-1500 2016-2018 T/Automática	5.3 L 6.2 L	23174588	SC60 Tramo Interior	 1446mm
SOBREMARCHA	840 CHSB	C-1500 TH700 1985-1986	0	25515598	SB2	 1060mm
ACELERADOR	1519 GMCA	C-1500 1988 - 1995	V6 Cil. 4.3 L	15552822	AC1	 780mm
	1552 GMCA	C-1500 Todos 1982-1986	V6 Cil. 4.3 L V8 Cil. 5.0 L 5.7 L	14038644	AC3	 967mm

GMC - C2500

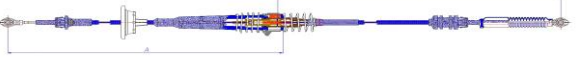
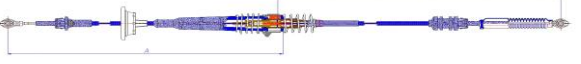
SELECTOR CAMBIOS	2914 GMSCC	C-2500 Traccion 2R 1995-2000 T/Automática	V6 Cil. 4.3 L	15037353	SC46	 2874mm
SOBREMARCHA	840 CHSB	C-2500 TH700 1985-1986	0	25515598	SB2	 1060mm
ACELERADOR	1519 GMCA	C-2500 1979-1986	V6 Cil. V8 Cil.	25515839	AC1	 630mm
	1552 GMCA	C-2500 Todos 1982-1986	V6 Cil. 4.3 L V8 Cil. 5.0 L 5.7 L	14038644	AC3	 967mm

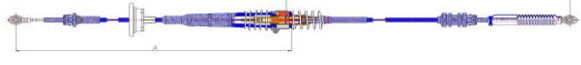
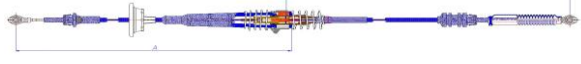
GMC - C3500

CONJUNTO SELECTOR CAMBIOS	3442 GMSCC	C3500 2001-2006 T/Automática	0	19167308	SC59	 3241mm
	3437 GMSCC	C3500 Traccion 2R 2000-2006 T/Automática	0	88967321	SC59	 3332mm
	3430 GMSCC	C3500 4WD 2000-2006 T/Automática	0	88967320	SC59	 3531mm
	3382 GMSCC	Sierra 1500, 2500 2007 T/Automática	4.3L 4.8L 5.3L	12477640	SC59	 3509mm
	4306 GMSCC	Sierra 2007-2014 T/Automática	V8 Cil. 5.3 L	0	SC77	 3391mm
	2914 GMSCC	C-3500 Traccion 2R 1985-1986 T/Automática	V6 Cil. 4.3 L	15037353	SC46	 2874mm

Encino 1287 col. del Fresno Guadalajara Jal.







Tel: Multilínea (33) 3811 6917 - Serv. Cliente Cel: 33 1992 6768 - Guadalajara, Jalisco
Correo: ventas@flexcontrol.com.mx - www.flexcontrol.com.mx - www.cablesnavcar.com

Automóvil - Suv - Van - Pickup - Camiones Pesados - Ligeros

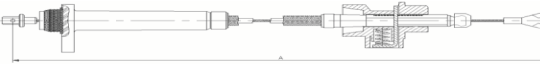
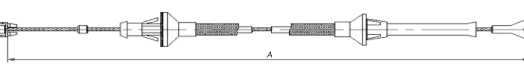
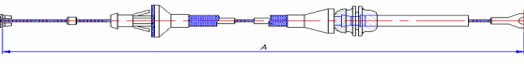

¡IMPORTANTE! Evite devoluciones o reclamos. Identifique previamente: marca, modelo y año del vehículo. En caso de duda, **CONSULTE** a su asesor.

NUESTRA MISIÓN... Ser su aliado en el desarrollo y crecimiento de su negocio

Competimos directamente con los ORIGINALES

LINEA	CODIGO	MODELO	MOTOR	O.E.M	ARMADO	IMAGEN -- LONGITUD
SELECTOR CAMBIOS	3434 GMSCS	C-3500 2000-2006 T/Automática	V6 Cil. 4.3 L	15784587	SC57 Tramo Inferior	 1645mm
	3435 GMSCS	C3500 2000-2006 T/Automática	V6 Cil. 4.3 L	15251896	SC58 Tramo Superior	 1892mm
	3436 GMSCS	C3500 Traccion 2R T/Automática	V6 Cil. 4.3 L	15784586	SC57 Tramo Inferior	 1446mm
	3440 GMSCS	C3500 1999-2007 T/Automática	V6 Cil. 4.3 L	25836132	SC57 Tramo Inferior	 1623mm
	3441 GMSCS	C3500 2001-2006 T/Automática	V6 Cil. 4.3 L	15822857	SC57 Tramo Inferior	 1355mm
SOBREMARCHA	840 CHSB	C3500 TH700 1985-1986	0	25515598	SB2	 1060mm
ACELERADOR	1519 GMCA	C-3500 1979-1986	V6 Cil. V8 Cil.	25515839	AC1	 630mm
	1552 GMCA	C-3500 1982-1986	V6 Cil. 4.3 L V8 Cil. 5.0 L 5.7 L	14038644	AC3	 967mm
ACELERADOR	3928 GMCAC	C-3500 2001-2002	V8 Cil. 5.3 L	15040848	AC247	 956mm

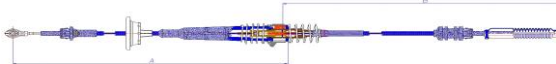
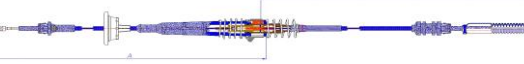
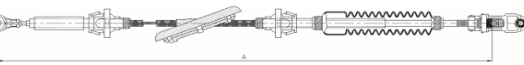
GMC - DENALI

CONJUNTO SELECTOR CAMBIOS	3382 GMSCS	Denali SL, SLE, SLT, WT, 4WD 2000 T/Automática	4.3 L 4.8 L 5.3 L	12477640	SC59	 3509mm
	3430 GMSCS	Denali 4WD 2001-2002 T/Automática	4.8 L 5.3 L 6.0 L	88967320	SC59	 3531mm
SELECTOR CAMBIOS	2914 GMSCS	Denali 1995-2000 T/Automática	V6 Cil. 4.3 L	15037353	SC46	 2874mm
	3761 GMSCS	Denali XL, XUV 2002 - 2009 T/Automática	4.2 L 5.3 L 6.0 L	15785087 10357836 15079394 15101412	SC79	 1886mm
CONJUNTO SELECTOR CAMBIOS	3715 GMSCS	Denali Traccion 2R 1/2, 3/4-Ton Traccion 2R 2007 - 2012	0	19177020	SC77	 3280mm

Automóvil - Suv - Van - Pickup - Camiones Pesados - Ligeros

¡IMPORTANTE! Evite devoluciones o reclamos. Identifique previamente: marca, modelo y año del vehículo. En caso de duda, **CONSULTE** a su asesor.

NUESTRA MISIÓN... Ser su aliado en el desarrollo y crecimiento de su negocio

Competimos directamente con los ORIGINALES

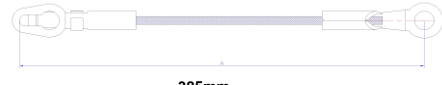
LINEA	CODIGO	MODELO	MOTOR	O.E.M	ARMADO	IMAGEN -- LONGITUD
	3716 GMCS	Denali Tracción 2R Tracción 4x4 2007 - 2012 T/Automática	0	19180564	SC77	 3370mm
SOPORTE COMPUERTA	3795 GMCSO	Denali 1999 - 2007	V6 Cil. 3.7 L V8 Cil. 4.7 L	16637944 16637945 88892972 88892973 88980509 88980510	CO6	 385mm

GMC - G15 - G25 - G35

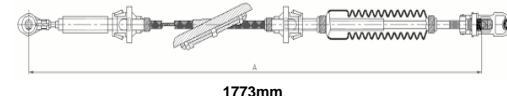
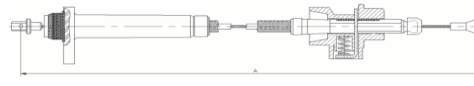
SELECTOR CAMBIOS	3692 GMCS	G25 1996-2002 T/Automática	V8 Cil. 6.5 L	15772247	SC46	 1773mm
SOBREMARCHA	840 CHSB	G15, G25, G35 R todos y TH700 1985-1986	0	25515598	SB2	 1060mm

GMC - G150 - G350

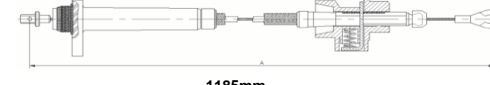
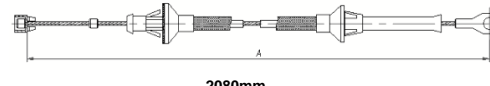
SOBREMARCHA	1622 GMSB	G150 / G350 THM700-4R 1983 - 1984	0	25515600	SB2	 1185mm
ACELERADOR	1523 GMCA	G150 / G350 Series Vans Motor 262Z305H 1987 - 1989	V6 Cil. 4.3 L	15552817	AC1	 2080mm

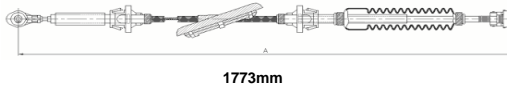
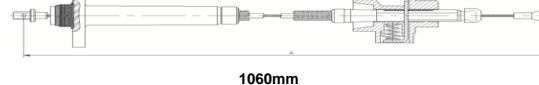
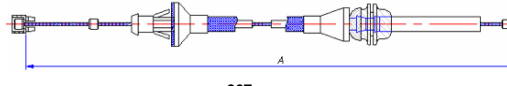

GMC - G1500 - G2500 - G3500

SELECTOR CAMBIOS	3692 GMCS	G2500 / G3500 Van 1996-2002 T/Automática	V8 Cil. 6.5 L	15772247	SC46	 1773mm
SOBREMARCHA	840 CHSB	G1500, G2500, G3500 R todos y , Vandura TH700 1985-1986	0	25515598	SB2	 1060mm
ACELERADOR	1552 GMCA	G2500 / G3500 Todos 1983-1991	V6 Cil. 4.3 L V8 Cil. 5.0 L 5.7 L	14038644	AC3	 967mm

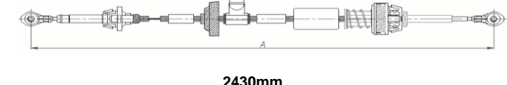
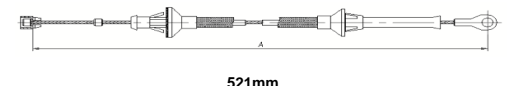
GMC - GRAND LEMANS

SELECTOR CAMBIOS	2154 GMCS	Grand Sport 1988 - 1996 T/Automática	0	12553933	SC28	 2430mm
ACELERADOR	353 ECAA	Grand LeMans 1975-1976	V8 Cil. 5.7 L 6.6 L	1252955	AC1	 521mm

GMC - HUMMER

SELECTOR CAMBIOS	3688 GMCS	Hummer H2 2003-2007	6.0 L	15268403 10356646 15055933	SC79	 955mm
SELECTOR CAMBIOS	4368 GMCS	Hummer H3 2006-2010	3.7 L	25800702	SC165	 1682mm





GMC - JIMMY

Automóvil - Suv - Van - Pickup - Camiones Pesados - Ligeros

IMPORTANTE. Evite devoluciones o reclamos. Identifique previamente: marca, modelo y año del vehículo. En caso de duda, **CONSULTE** a su asesor.

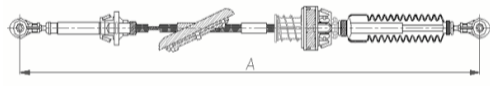
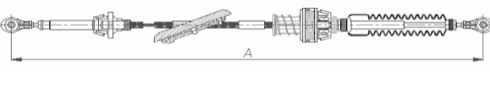
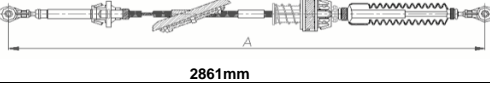
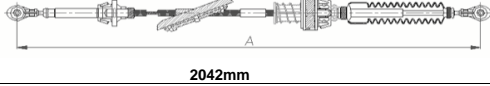
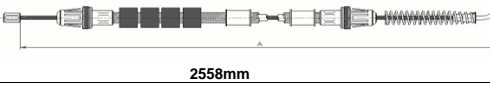
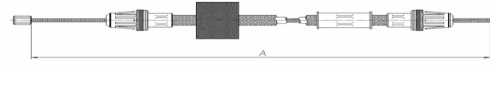
NUESTRA MISIÓN... Ser su aliado en el desarrollo y crecimiento de su negocio

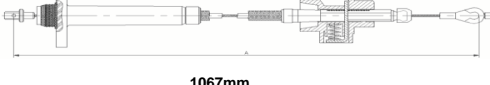
Competimos directamente con los ORIGINALES

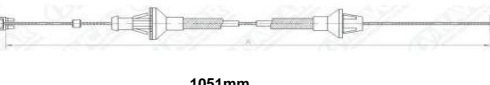
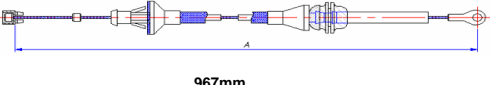
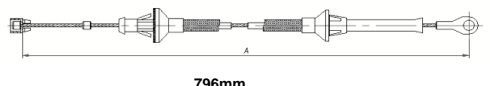
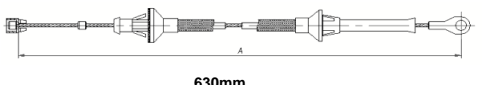
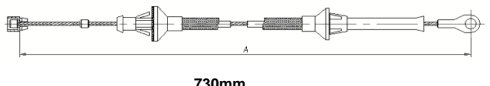
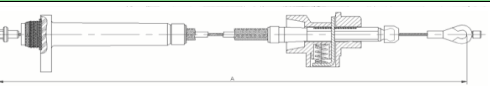





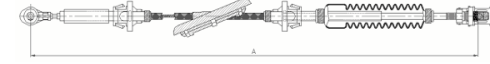

LINEA	CODIGO	MODELO	MOTOR	O.E.M	ARMADO	IMAGEN -- LONGITUD
SELECTOR CAMBIOS	2159 GMCS	Jimmy Traccion 4x4 1996-1997 T/Automática	V6 Cil. 4.3 L	15021558 15713353	SC27	 2800mm
	3402 GMCS	Jimmy Traccion 4x4 1995-1997 T/Automática	V6 Cil. 4.3 L	15721261	SC27 Palanca al volante	 2576mm
	3807 GMCS	Jimmy 1998-2005 T/Automática	V6 Cil. 4.3 L	15189203	SC27	 2861mm
	3866 GMCS	Jimmy 1998-2005 T-Automática	L4 Cil. 2.2 L V6 Cil. 4.3 L	15189199	SC27	 2042mm
FRENO DE MANO	2818 GMCFP	Jimmy 2000 - 2004	V6 Cil. 4.3 L	15087072	FP263	 2558mm
	3108 GMCFP	Jimmy Traccion 4x4 1996-1997	V6 Cil. 4.3 L	15709831 15741310	FP272 Trasero Izquierdo	 1758mm
SOBREMARCHA	840 CHSB	Jimmy TH700 1985-1986	0	25515598	SB2	 1060mm
	2036 GMCSB	Jimmy 1992	V6 Cil. 4.3 L	10142019	SB2	 1067mm
SOPORTE COMPUERTA	3639 GMCSO	Jimmy 1973 - 1982	V6 Cil. 3.7 L V8 Cil. 4.7 L	6274850	CO4	 556mm
ACELERADOR	3443 GMCAC	Jimmy Traccion 2R Traccion 4x4 1996 - 1997	V6 Cil. 4.1 L	15733071	AC116	 1051mm
	1552 GMCA	Jimmy Todos 1983-1990	V6 Cil. 4.3 L V8 Cil. 5.0 L 5.7 L	14038644	AC3	 967mm
	1524 GMCA	Jimmy Motor 262Z 1988 - 1990	V6 Cil. 4.3 L	15622442	AC1	 796mm
	1519 GMCA	Jimmy Motor 305F 1983 - 1986	V6 Cil. V8 Cil.	25515839	AC1	 630mm
	1520 GMCA	Jimmy Motor 350K - 454N 1988 - 1990	V6 Cil. 4.3 L	15551476	AC1	 730mm
GMC - K15 - K25 - K35						
SOBREMARCHA	840 CHSB	K15 / K25 / K35 Traccion 4x4 TH700 1985-1986	0	25515598	SB2	 1060mm

Automóvil - Suv - Van - Pickup - Camiones Pesados - Ligeros

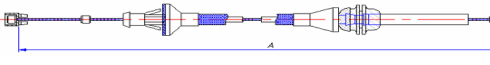
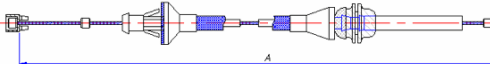
IMPORTANTE. Evite devoluciones o reclamos. Identifique previamente: marca, modelo y año del vehículo. En caso de duda, **CONSULTE** a su asesor.

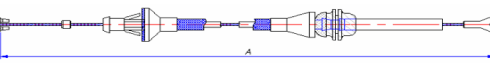
NUESTRA MISIÓN... Ser su aliado en el desarrollo y crecimiento de su negocio

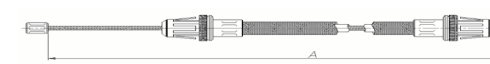
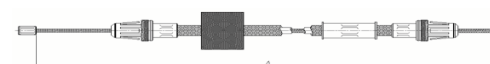
Competimos directamente con los ORIGINALES





LINEA	CODIGO	MODELO	MOTOR	O.E.M	ARMADO	IMAGEN -- LONGITUD
SOPORTE COMPUERTA	3639 GMCSO	K25 1973 - 1982	V6 Cil. 3.7 L	6274850	CO4	 556mm
			V8 Cil. 4.7 L			
GMC - K1500, K2500, K3500						
SELECTOR CAMBIOS	2914 GMCSO	K1500 / K2500 / K3500 Traccion 4x4 1995-2000 T/Automática	V6 Cil. 4.3 L	15037353	SC46	 2874mm
SOBREMARCHA	840 CHSB	K1500 / K2500 / K3500 Traccion 4x4 TH700 1985-1986	0	25515598	SB2	 1060mm
ACELERADOR	1552 GMCA	K1500 / K2500 / K3500 Todos 1982-1986	V6 Cil. 4.3 L	14038644	AC3	 967mm
	1563 GMCA		V8 Cil. 5.0 L 5.7 L			
		K1500 / K2500 / K3500 1988-1990	V8 Cil. 6.2 L	15552819	AC3	 1248mm
GMC - MICROBUS						
ACELERADOR	1832 GMCAC	Microbus 1982 - 1985	V8 Cil.	3998768	AC1	 1728mm
	3409 GMCAC	Microbus 1991-1995	V8 Cil.	15990937	AC246	 1702mm
GMC - R1500 - R2500 - R3500						
ACELERADOR	1552 GMCA	R1500 / R2500 / R3500 Todos 1987-1990	V6 Cil. 4.3 L V8 Cil. 5.0 L 5.7 L	14038644	AC3	 967mm
GMC - S15						
EMBRAGUE	2277 GMCEM	S15 1982-1983	V6 Cil. 2.8 L	14030848	EM94 Con Tope	 440mm
	2276 GMCEM	S15 1982-1983	V6 Cil. 2.8 L	14062618	EM93 Con Tornillo	 188mm
FRENO DE MANO	2621 GMCFF	S15 1998 - 2001	V6 Cil. 4.3 L	15724598	FP240 Principal	 923mm
	3108 GMCFF	S15 Traccion 4x4 1996-1997	V6 Cil. 4.3 L	15709831 15741310	FP272 Trasero izquierdo	 1758mm
SOBREMARCHA	1621 GMSB	S15 1985 - 1986	0	25517311	SB2	 1335mm

Automóvil - Suv - Van - Pickup - Camiones Pesados - Ligeros

IMPORTANTE. Evite devoluciones o reclamos. Identifique previamente: marca, modelo y año del vehículo. En caso de duda, **CONSULTE** a su asesor.

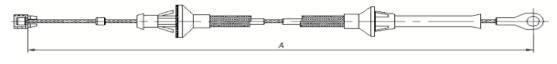
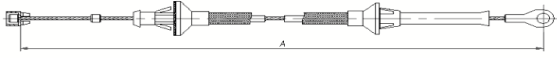
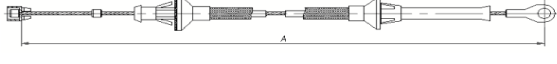
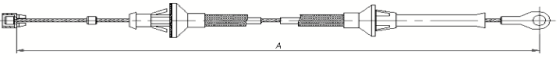
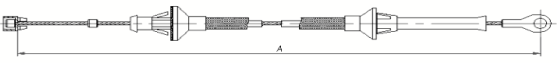
NUESTRA MISIÓN... Ser su aliado en el desarrollo y crecimiento de su negocio

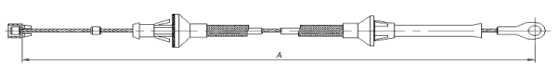
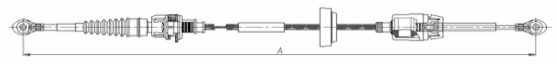
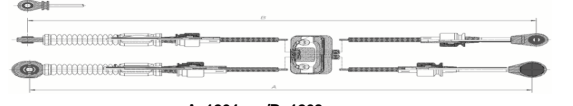
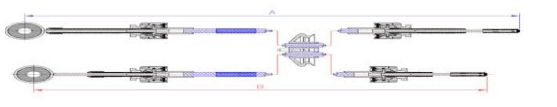
Competimos directamente con los ORIGINALES

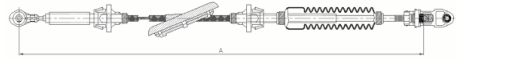









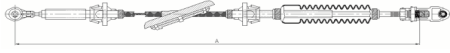
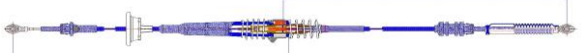

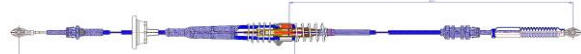
LINEA	CODIGO	MODELO	MOTOR	O.E.M	ARMADO	IMAGEN -- LONGITUD
SOBREMARCHA	2040 GMCSB	S15 1991	0	10111682	SB2	 1028mm
ACELERADOR	1556 GMCA	S15 1982-1986	4.Cil 1.9L	15590109 15592356	AC1	 1023mm
	1561 GMCA	S 15 Jimmy 1986 - 1990	V6 Cil. 2.8 L	15622471	AC1	 855mm
	1524 GMCA	S15 Motor 262Z 1988 - 1990	V6 Cil. 4.3 L	15622442	AC1	 796mm
	1551 GMCA	S15 1982 - 1985	V6 Cil. 2.8 L	14036110	AC1	 760mm
	1556 GMCA	S 15 1985 - 1986	V6 Cil. 2.5 L	15590109 15592356	AC1	 1023mm
GMC - SAFARI						
SOBREMARCHA	2036 GMCSB	Safari 1992	V.6 Cil. 4.3 L	10142019	SB2	 1067mm
SOBREMARCHA	2040 GMCSB	Safari Traccion 2R, Traccion 4R 1991-1992	0	10111682	SB2	 1028mm
ACELERADOR	1556 GMCA	Safari 1985 - 1986	V6 Cil. 2.5 L	15590109 15592356	AC1	 1023mm
GMC - SATURN						
SELECTOR CAMBIOS	3056 GMCSB	Saturn Series SC, SL, SW 1991-2002 T/Automática	L4 Cil. 1.9 L	21002570	SC30	 1270mm
KIT CONTROL Y SELECTOR CAMBIOS	2717 GMCCB	Saturn Series SL-SC-SW 1991-2002 T/Estándar	0	21120125 21005846	CC33	 A=1264mm/B=1268mm
KIT CONTROL Y SELECTOR CAMBIOS	4290 SATCC	Saturn Vue 2004-2007 T Estandar	0	21996492	CC126	 A=1830mm/B=1761mm
FRENO DE MANO	2785 GMCFP	Saturn Series SL, SW 1991 - 1994	0	21011306	FP240 Trasero Izquierdo	 1747mm
GMC - SAVANA						
SELECTOR	3693 GMCSB	Savana Gasolina 1996-2002 T/Automática	V8 Cil. 7.5 L	15772245	SC46	 1731mm

Automóvil - Suv - Van - Pickup - Camiones Pesados - Ligeros

IMPORTANTE. Evite devoluciones o reclamos. Identifique previamente: marca, modelo y año del vehículo. En caso de duda, **CONSULTE** a su asesor.

NUESTRA MISIÓN... Ser su aliado en el desarrollo y crecimiento de su negocio

Competimos directamente con los ORIGINALES

LINEA	CODIGO	MODELO	MOTOR	O.E.M	ARMADO	IMAGEN -- LONGITUD
CAMBIOS	3692 GMSCS	Savana 1996-2002 T/Automática	V8 Cil. 6.5 L	15772247	SC46	 1773mm
GMC - SIERRA						
CONJUNTO SELECTOR CAMBIOS	3439 GMSCS	Sierra 2000-2002 T/Automática	V6 Cil. 4.3 L 4.8 L 5.3 L 5.7 L 6.0 L	12477639	SC59	 3332mm
	3430 GMSCS	Sierra 1500, 2500, 3500 Traccion 4x4 WT 2001-2002	0	88967320	SC59	 3531mm
	3437 GMSCS	Sierra 1500, 2500 Traccion 2R 2000-2006	0	88967321	SC59	 3332mm
SELECTOR CAMBIOS	2914 GMSCS	Sierra 1995-2000 T/Automática	V6 Cil. 4.3 L	15037353	SC46	 2874mm
	3438 GMSCS	Sierra Traccion 2R 1999-2007 T/Automática	V6 Cil. 4.3 L	15118283	SC57 Tramo Inferior	 1446mm
	3465 GMSCS	Sierra Traccion 4x4 2007-2012 T/Automática	V6 Cil. 4.3 L 4.8 L 5.3 L 5.7 L 6.0 L	20787606	SC60 Tramo Inferior	 1620mm
	3467 GMSCS	Sierra 2007-2012 T/Automática	V6 Cil. 4.3 L 4.8 L 5.3 L 5.7 L 6.0 L	20787610	SC60 Tramo Inferior	 1446mm
	3867 GMSCS	Sierra 2010 - 2014 T/Automática	0	25995571	SC60 Tramo Inferior	 1374mm
	3466 GMSCS	Sierra 1500; 2500; 3500 HD 2007-2009 T/Automática	V6 Cil. 4.3 L 4.8 L 5.3 L 5.7 L 6.0 L	20787607	SC60 Tramo Inferior	 1397mm
SELECTOR CAMBIOS	3436 GMSCS	Sierra 1500, 2500 Taccion 2R 2000-2006 T/Automática	V6 Cil. 4.3 L	15784586	SC57 Tramo Inferior	 1446mm
	3435 GMSCS	Sierra Traccion 2R 1500, 2500 2000-2006 T/Automática	V6 Cil. 4.3 L	15251896	SC58 Tramo Superior	 1892mm
	3434 GMSCS	Sierra 1500, 2500, 3500 2000-2006 T/Automática	V6 Cil. 4.3 L	15784587	SC57 Tramo Inferior	 1645mm
	4308 GMSCS	Sierra 2016-2018 T/Automática	V8 Cil. 5.8L	0	SC60 Tramo Inferior	 1576mm

Encino 1287 col. del Fresno Guadalajara Jal.





Tel. Multilínea (33) 3811 6917 - Servi-Cliente Cel. 33 1992 6768 - Guadalajara, Jalisco
Correo: ventas@flexcontrol.com.mx - www.flexcontrol.com.mx - www.cablesnavcar.com

Automóvil - Suv - Van - Pickup - Camiones Pesados - Ligeros

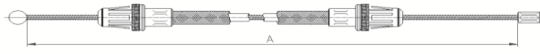

IMPORTANTE. Evite devoluciones o reclamos. Identifique previamente: marca, modelo y año del vehículo. En caso de duda, **CONSULTE** a su asesor.

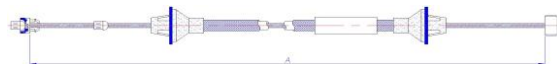
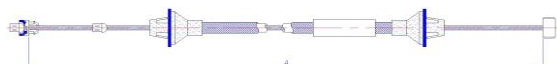
NUESTRA MISIÓN... Ser su aliado en el desarrollo y crecimiento de su negocio

Competimos directamente con los ORIGINALES

LINEA	CODIGO	MODELO	MOTOR	O.E.M	ARMADO	IMAGEN -- LONGITUD
FRENO DE MANO	2730 GMC FP	Sierra 2006 - 2007	V6 Cil. 4.3 L 4.8 L	15215322	FP218	 1705mm
	3083 GMC FP	Sierra 3500 Clasicc LT, LS, WT, SLT, SLE 2001 - 2007	V8 6.0L 6.6L 8.1L	15017171	FP63 Trasero Izquierdo	 2217mm
	3079 GMC FP	Sierra 2001-2007	V8 Cil. 6.0L, 6.6L 8.1L	15020670 15130818	FP63 Trasero Derecho	 2270mm
ACELERADOR	3445 GMC AC	Sierra 1999-2000	V6 Cil. 4.3 L 4.8 L	15712337 22542664 15040848	AC247	 960mm
	3928 GMC AC	Sierra 1500 - 3500, 2001-2002	V6 Cil. 4.3 L	15040848	AC247	 956mm
SOPORTE COMPUERTA	3795 GMC SO	Sierra 1999 - 2007	V6 Cil. 3.7 L V8 Cil. 4.7 L	16637944 16637945 88892972 88892973 88980509 88980510	CO6	 385mm

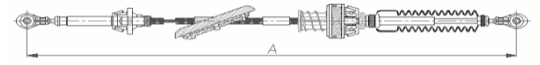
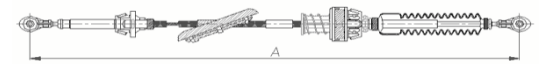
GMC - SONOMA

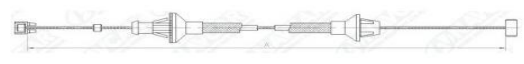
SELECTOR CAMBIOS	3807 GMC SC	Sonoma 1998-2005 T/Automática	V6 Cil. 4.3 L	15189203	SC27	 2861mm
	3866 GMC SC	Sonoma 1998-2005 T/Automática	L4 Cil. 2.2 L V6 Cil. 4.3 L	15189199	SC27	 2042mm
SOBREMARCHA	2036 GMC SB	Sonoma 1992	0	10142019	SB2	 1067mm
	2040 GMC SB	Sonoma Traccion 2R Traccion 4x4 1991	0	10111682	SB2	 1028mm
ACELERADOR	3443 GMC AC	Sonoma Traccion 2R, Traccion 4x4 1996 - 1997	V6 Cil. 4.1 L	15733071	AC116	 1051mm

GMC - SYCLONE

SOBREMARCHA	2040 GMC SB	Syclone Traccion 2R, Traccion 4x4 1991	0	10111682	SB2	 1028mm
-------------	----------------	---	---	----------	-----	--

GMC - TYPHOON

SOBREMARCHA	2040 GMC SB	Typhoon Traccion 4x4 1991	0	10111682	SB2	 1028mm
-------------	----------------	---------------------------------	---	----------	-----	--







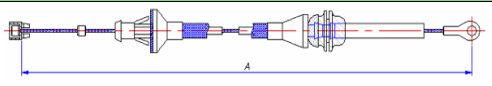
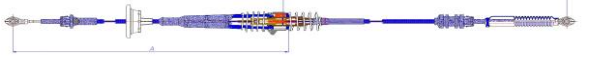
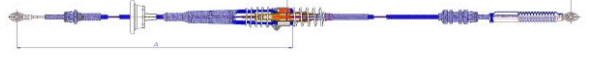
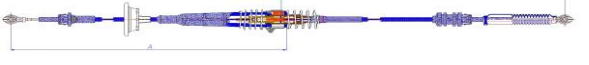
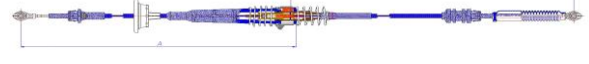
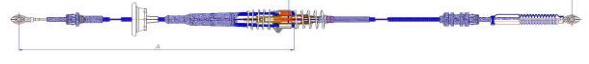

GMC - V1500

Automóvil - Suv - Van - Pickup - Camiones Pesados - Ligeros

IMPORTANTE. Evite devoluciones o reclamos. Identifique previamente: marca, modelo y año del vehículo. En caso de duda, **CONSULTE** a su asesor.

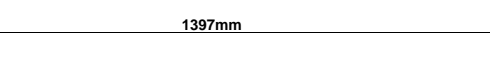
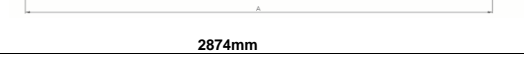
NUESTRA MISIÓN... Ser su aliado en el desarrollo y crecimiento de su negocio

Competimos directamente con los ORIGINALES







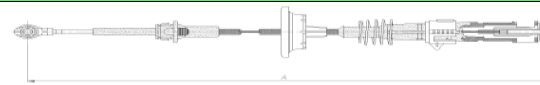
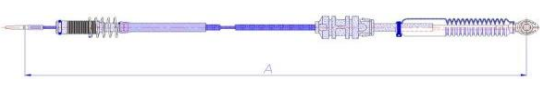
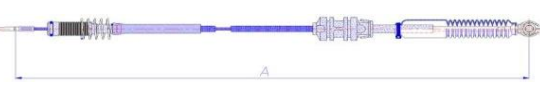
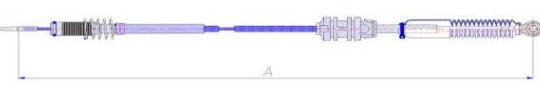

LINEA	CODIGO	MODELO	MOTOR	O.E.M	ARMADO	IMAGEN -- LONGITUD
ACELERADOR	1552 GMCA	V1500, V2500, V3500 Todos 1987-1990	V6 Cil. 4.3 L V8 Cil. 5.0 L 5.7 L	14038644	AC3	 967mm
GMC - YUKON						
CONJUNTO SELECTOR CAMBIOS	3382 GMSC	Yukon 1999-2007 T/Automática	0	12477640	SC59	 3509mm
	3430 GMSC	Yukon 4WD 2001-2006 T/Automática	0	88967320	SC59	 3531mm
	3437 GMSC	Yukon XL 1500, 2500 Traccion 2R 2000-2006 T/Automática	0	88967321	SC59	 3332mm
	3442 GMSC	Yukon 2001-2006 T/Automática	0	19167308	SC59	 3241mm
CONJUNTO SELECTOR CAMBIOS	3439 GMSC	Yukon Traccion 2R 1999-2007 T/Automática	0	12477639	SC59	 3332mm
SELECTOR CAMBIOS	3465 GMSC	Yukon 2007-2012 T/Automática	V6 Cil. 4.3 L 4.8 L 5.3 L 5.7 L 6.0 L	20787606	SC60 Tramo Inferior	 1620mm
	3467 GMSC	Yukon Traccion 2R 2007-2012 T/Automática	V6 Cil. 4.3 L 4.8 L 5.3 L 5.7 L 6.0 L	20787610	SC60 Tramo Inferior	 1446mm
	3466 GMSC	Yukon Traccion 2R Hybrid 2007-2009 T/Automática	V6 Cil. 4.3 L 4.8 L 5.3 L 5.7 L 6.0 L	20787607	SC60 Tramo Inferior	 1397mm
	2914 GMSC	Yukon Traccion 2R, Traccion 4x4 1995-2000 T/Automática	V6 Cil. 4.3 L	15037353	SC46	 2874mm
	3715 GMSC	Yukon Traccion 2R 2007 - 2012 T/Automática	0	19177020	SC77	 3280mm
	3716 GMSC	Yukon Traccion 2R, Traccion 4x4 2007 - 2012 T/Automática	0	19180564	SC77	 3370mm
	4306 GMSC	Yukon 2007 - 2014 T/Automática	0	0	SC77	 3391mm
	3434 GMSC	Yukon 2000-2006 T/Automática	V6 Cil. 4.3 L	15784587	SC57 Tramo Inferior	 1645mm

Automóvil - Suv - Van - Pickup - Camiones Pesados - Ligeros

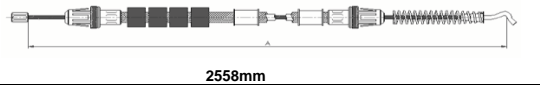
IMPORTANTE. Evite devoluciones o reclamos. Identifique previamente: marca, modelo y año del vehículo. En caso de duda, **CONSULTE** a su asesor.

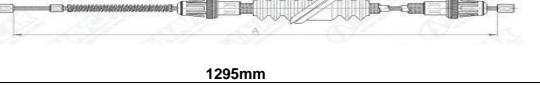
NUESTRA MISIÓN... Ser su aliado en el desarrollo y crecimiento de su negocio

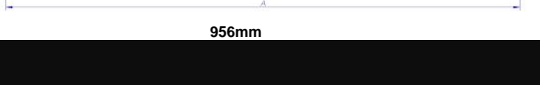
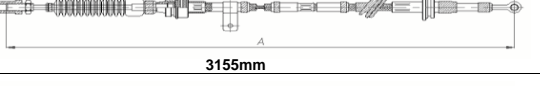
Competimos directamente con los ORIGINALES







LINEA	CODIGO	MODELO	MOTOR	O.E.M	ARMADO	IMAGEN -- LONGITUD
	3435 GMSCC	Yukon 2000-2006 T/Automática	V6 Cil. 4.3 L	15251896	SC58 Tramo Superior	 1892mm
	3436 GMSCC	Yukon 2000-2006 T/Automática	V6 Cil. 4.3 L	0	SC57 Tramo Inferior	 1446mm
	3441 GMSCC	Yukon 2001-2006 T/Automática	V6 Cil. 4.3 L	15822857	SC57 Tramo Inferior	 1355mm
	3438 GMSCC	Yukon Traccion 2R 1999-2007 T/Automática	V6 Cil. 4.3 L	15118283	SC57 Tramo Inferior	 1446mm
	3440 GMSCC	Yukon Traccion 4x4 1999-2007 T/Automática	V6 Cil. 4.3 L	25836132	SC57 Tramo Inferior	 1623mm
FRENO DE MANO	2818 GMCFP	Yukon 2000 - 2004	V6 Cil. 4.3 L	15087072	FP263	 2558mm
	2769 GMCFP	Yukon 1992 - 1994	V8 Cil. 4.8 L 5.3 L	15640541	FP239 Trasero Izquierdo	 1952mm
	2685 GMCFP	Yukon XL 2500 1995-2002	V8 Cil. 4.8 L 5.3 L	15043361 15706385 15720251	FP223 Principal	 1295mm
ACELERADOR	3445 GMCAC	Yukon 1999-2000	V6 Cil. 4.3 L 4.8 L	15712337 22542664 15040848	AC247	 960mm
	3928 GMCAC	Yukon 2001-2002	V8 Cil. 5.3 L	15040848	AC247	 956mm
HINO						
HINO - FB						
CONTROL CAMBIOS (Transversal)	2096 HINCC	FB 4JJ / 4JG 2001... T/Estándar	0	337023531	CC14	 3155mm
SELECTOR CAMBIOS (Selector)	2097 HINSC	FB 4JJ / 4JG 2001... T/Standar	FP2	337023521	SC22	 3172mm
FRENO DE MANO	2709 HINFP	FB 1999...	0	S464022741	FP233 Trasero Derecho	 4928mm

Automóvil - Suv - Van - Pickup - Camiones Pesados - Ligeros

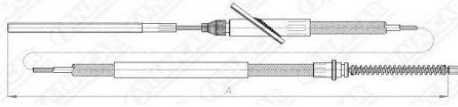
IMPORTANTE. Evite devoluciones o reclamos. Identifique previamente: marca, modelo y año del vehículo. En caso de duda, **CONSULTE** a su asesor.

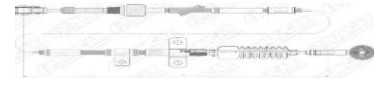
NUESTRA MISIÓN... Ser su aliado en el desarrollo y crecimiento de su negocio

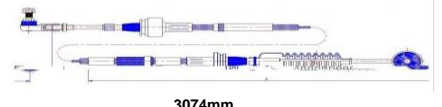
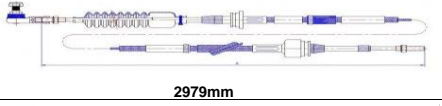
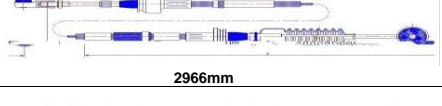
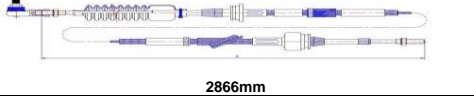
Competimos directamente con los ORIGINALES

LINEA	CODIGO	MODELO	MOTOR	O.E.M	ARMADO	IMAGEN -- LONGITUD
FRENO DE MANO	2708 HINFP	FB 1999...	0	S464025431	FP233 Trasero Izquierdo	 4441mm
HINO - FC						
SELECTOR CAMBIOS (Selector)	2714 HINSC	FC 2000 - 2009 T/Estándar	0	S33830E0251	SC45	 3670mm
CONTROL CAMBIOS (Transversal)	2715 HINCC	FC 2000 - 2009 T/Standar	0	S337025953	CC30	 3485mm
HINO - GH- RM- FM						
CONTROL CAMBIOS (Transversal)	3190 HINCC	GH,RM,FM 2004.... T/Estándar	0	33820-E0D30	CC35	 3359mm
HINO- FG						
CONTROL CAMBIOS (Transversal)	4121 HINCC	FG Serie 500 2006-2011	0	#####	CC102	 4287mm
SELEECTOR CAMBIOS (Selector)	4122 HINSC	FG Serie 500 2006-2011	0	33820E0A40	SC114	 4083mm
HINO - serie 300						
CONTROL CAMBIOS (Transversal)	3922 HINCC	HINO 414, 514, 614 Series 300 Diesel 5 velocidades 2006-2011	L4 Cil. 3.8 L	33820-37M70	CC71	 3074mm
SELECTOR CAMBIOS (Selector)	3923 HINSC	HINO 414, 514, 614 Series 300 Diesel 5 velocidades 2006-2011	L4 Cil. 3.8 L	33830-37640	SC89	 2979mm
CONTROL CAMBIOS (Transversal)	3925 HINCC	HINO 616, 716, 716 Series 300 Diesel 5 velocidades 2011-2015	L4 Cil. 3.8 L	33820-37G70	CC71	 2966mm
SELECTOR CAMBIOS (Selector)	3926 HINSC	HINO 616, 716, 716 Series 300 Diesel 5 velocidades. 2011-2015	L4 Cil. 3.8 L	33830-37641	SC89	 2866mm
CONTROL CAMBIOS (Transversal)	3954 HINCC	Series 300 - 500 2009-2015 T/Estándar	0	33820-E0E00	CC75	 3408mm
CONTROL CAMBIOS (Transversal)	4124 HINCC	Serie 300 / 500 chasis AK 2010...	0	33830-E0133	CC102	 3617mm

Automóvil - Suv - Van - Pickup - Camiones Pesados - Ligeros

IMPORTANTE. Evite devoluciones o reclamos. Identifique previamente: marca, modelo y año del vehículo. En caso de duda, **CONSULTE** a su asesor.

NUESTRA MISIÓN... Ser su aliado en el desarrollo y crecimiento de su negocio

Competimos directamente con los ORIGINALES

LINEA	CODIGO	MODELO	MOTOR	O.E.M	ARMADO	IMAGEN -- LONGITUD
CONTROL CAMBIOS (Transversal)	4159 HINCC	Serie 300 version 816 2007-2012	0	0	CC106	 2800mm

HINO - serie 500

CONTROL CAMBIOS (Transversal)	3954 HINCC	Serie 500 2009-2015 T/Estándar	0	33820-E0E00	CC75	 3408mm
SELECTOR CAMBIOS (Selector)	4123 HINSC	Hino 500 2010.. T/Estándar	0	0	SC115	 3410mm
CONTROL CAMBIOS (Transversal)	4158 HINCC	Hino 500 2008-2012 T/Estándar	0	33820G0Y60	CC105	 3380mm

HINO - HINO 700

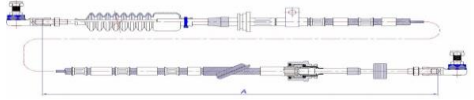
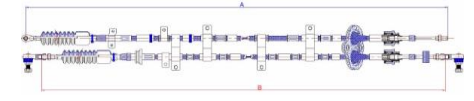

SELECTOR CAMBIOS (Selector)	4272 HINSC	Hino 700 2007-2009 T/Estándar	0	0	SC148	 5515mm
KIT CONTROL Y SELECTOR CAMBIOS	4273 HINCC	Hino 700 2007-2009 T/Estándar	0	33830E0691	CC123	 A=5736mm/B=5515mm

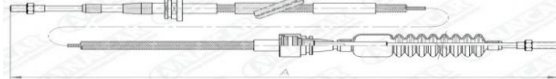
HINO - SUPER HINO

CONTROL CAMBIOS (Transversal)	2019 HINSE	Super 2002... T/Standar	0	0	SC19	 3338mm
-------------------------------	----------------------	----------------------------	---	---	------	--

HONDA

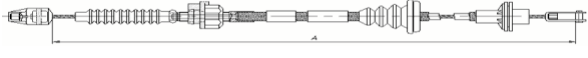
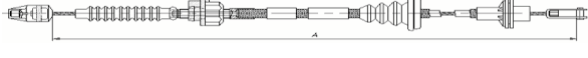
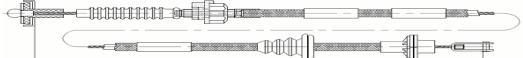
HONDA - ACCORD





EMBRAGUE	1319 HONE	Accord SY100 - SZ120 1982-1984	L4 Cil. 2.2 L	22910SA5671	EM66	 1576mm
	1320 HONE	Accord 1983-1985	L4 Cil. 2.2 L	22910SA5672	EM66	 1811mm
	1323 HONE	Accord CA 1985 - 1989	L4 Cil. 2.2 L	22910SE0A01	EM69	 1920mm
ACELERADOR	2426 HONAC	Accord 1990 - 1993	L4 Cil. 2.2 L	24360PX40134	AC205	 885mm
	3771 HONAC	Accord EX, LX; Coupe, Sedan 5 velocidades 1994-1997	L4 Cil. 2.2 L	17910SV4A01	AC267	 739mm

Automóvil - Suv - Van - Pickup - Camiones Pesados - Ligeros

IMPORTANTE. Evite devoluciones o reclamos. Identifique previamente: marca, modelo y año del vehículo. En caso de duda, **CONSULTE** a su asesor.

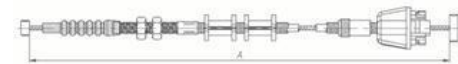
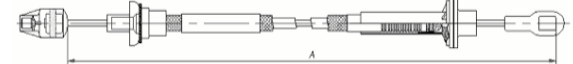
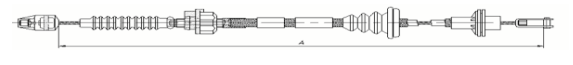
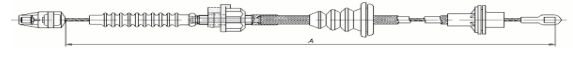
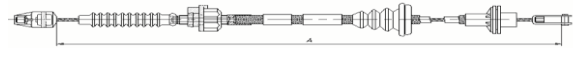
NUESTRA MISIÓN... Ser su aliado en el desarrollo y crecimiento de su negocio

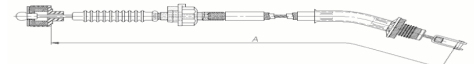
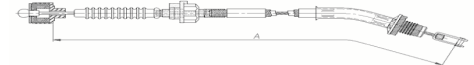
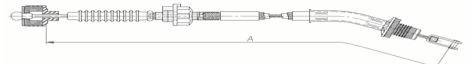
Competimos directamente con los ORIGINALES

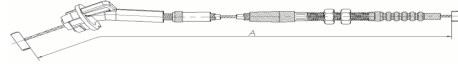
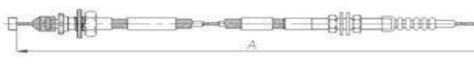
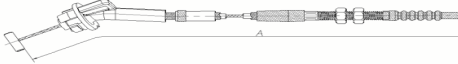
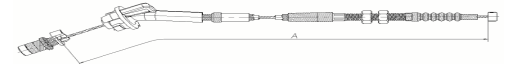
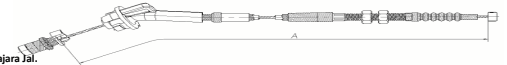





LINEA	CODIGO	MODELO	MOTOR	O.E.M	ARMADO	IMAGEN -- LONGITUD
ACCELERADOR	3772 HONAC	Accord Todos Estándar 1994 - 1997	0	17910-SM4-A31	AC267	 729mm
	2361 HONAC	Accord 2156 (SOCH & VTEC) w/AT 1994-1997	L4 Cil. 2.2 L	17910SV4A81	AC193	 743mm
HONDA - CIVIC						
EMBRAGUE	1077 HONE	Civic 1975 - 1979	L4 Cil. 1.5 L	22910657670	EM67	 1285mm
	1074 HONE	Civic 1979 - 1984	L4 Cil. 1.5 L	22910SAO674/3	EM66	 1462mm
	1075 HONE	Civic 1980 - 1987	L4 Cil. 1.5 L	22910SAO670	EM65	 1447mm
	1076 HONE	Civic 1984 - 1987	L4 Cil. 1.5 L	22910SB2672	EM66	 1535mm
	2750 HONEM	Civic 1988 - 1991	L4 Cil. 1.5 L	22910SH5A03 22910SK7A80	EM68	 1553mm
	1078 HONE	Civic 1988 - 1991	L4 Cil. 1.5 L	22910SH5A03 22910SK7A80	EM68	 1513mm
	1464 HONE	Civic Todos T.T. - CRX 1987...	L4 Cil. 1.5 L	22910SH3A05	EM68	 1540mm
EMBRAGUE	3682 HONEM	Civic Traccion 2R Wagon 1988-1991	L4 Cil. 1.5 L	22910-SH5-A02	EM68	 1517mm
VELOCIMETRO	1778 HONVZ	Civic 1988 - 1991	L4 Cil. 1.5 L	78410-SH3-A02	VZ63	 884mm
ACCELERADOR	2360 HONAC	Civic 1994 - 1995	L4 Cil. 1.5 L	17910SR3A51	AC194	 980mm
	2428 HONAC	Civic 1992 - 1995	L4 Cil. 1.5 L	24360P24A016M1	AC207	 841mm
	2360 HONAC	Civic 1993 - 1995	L4 Cil. 1.5 L	17910SR3A51	AC194	 980mm
	2358 HONAC	Civic 1994 - 1997	L4 Cil. 1.5 L	17910SR3L01	AC195	 982mm
	2874 HONAC	Civic Crx 1500 1984-1987	0	17910SB26710M1	AC197	 1007mm

Automóvil - Suv - Van - Pickup - Camiones Pesados - Ligeros

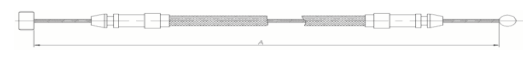
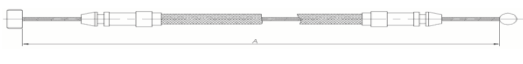
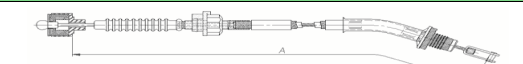
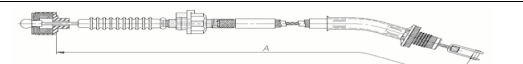
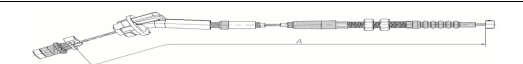
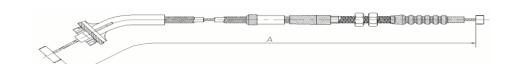
IMPORTANTE. Evite devoluciones o reclamos. Identifique previamente: marca, modelo y año del vehículo. En caso de duda, **CONSULTE** a su asesor.

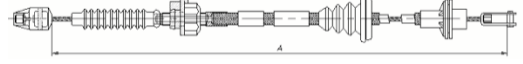
NUESTRA MISIÓN... Ser su aliado en el desarrollo y crecimiento de su negocio

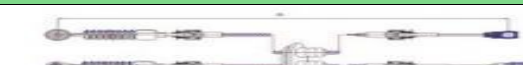
Competimos directamente con los ORIGINALES









LINEA	CODIGO	MODELO	MOTOR	O.E.M	ARMADO	IMAGEN -- LONGITUD
APERTURA COFRE	315 HONC	Civic 1988 - 1991	V6 Cil. 3.7 V8 Cil. 4.7 L	74130SH3A016	CP9 Sin Manija	 2483mm
	316 HONC	Civic 1992 - 1995	V6 Cil. 3.7 V8 Cil. 4.7 L	74130SR3A001	CP9 Sin Manija	 2398mm
HONDA/ACURA- INTEGRA						
EMBRAGUE	1078 HONE	Integra 1992-1993	L4 Cil. 1.5 L	22910SH5A03 22910SK7A80	EM68	 1513mm
	3085 HONEM	Integra RS, LS, GS 1990-1993	L4 Cil. 1.8 L	22910SK7A02	EM68	 1498mm
ACELERADOR	2358 HONAC	Integra 1834 exc. GSR 1994 - 2001	L4 Cil. 1.5 L	17910SR3L01	AC195	 982mm
HONDA - ODYSSEY						
ACELERADOR	2359 HONAC	Odyssey 1995 - 1997	L4 Cil. 2.2 L	17910SX0A81	AC196	 1273mm
HONDA - QUINTET						
EMBRAGUE	1074 HONE	Quintet 1980 - 1983	L4 Cil. 1.5 L	22910SA0674/3	EM66	 1462mm
HONDA - PRELUDE						
EMBRAGUE	1321 HONE	Prelude 1983 - 1988	L4 Cil. 2.0 L	22910SB0670	EM66	 1442mm
HYUNDAI						
HYUNDAI -Accent						
KIT CONTROL Y SELECTOR CAMBIOS	1083 HYUC	Accent 1995 - 1998 T/Estándar	0	4379422010	CC5	 A=1120mm/B=1150mm
HYUNDAI -GRAND STRAREX						
KIT CONTROL Y SELECTOR CAMBIOS	4070 HYUCC	Starex H1 Wagon Van Diesel 2008-2015 T/Estándar	2.5L	43794-4H050	CC99	 A=934mm/B=1000mm
FRENO DE MANO	3992 HYUFP	Grand Starex H-1 2008...	2.7L	59770-4H00	FP415 Trasero Derecho	 1780mm

Automóvil - Suv - Van - Pickup - Camiones Pesados - Ligeros

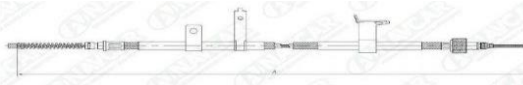
¡IMPORTANTE! Evite devoluciones o reclamos. Identifique previamente: marca, modelo y año del vehículo. En caso de duda, **CONSULTE** a su asesor.

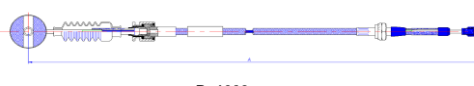
NUESTRA MISIÓN... Ser su aliado en el desarrollo y crecimiento de su negocio

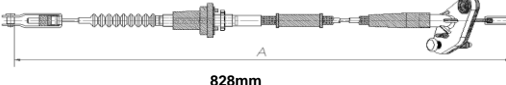
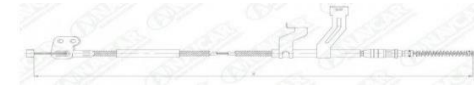
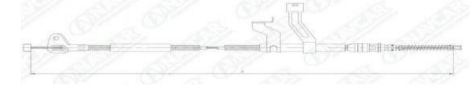
Competimos directamente con los ORIGINALES

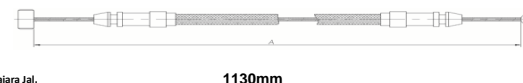
LINEA	CODIGO	MODELO	MOTOR	O.E.M	ARMADO	IMAGEN -- LONGITUD
FRENO DE MANO	3994 HYUFP	Grand Starex H-1 2008....	2.7L	59760-4H00	FP415 Trasero Izquierdo	 1782mm
HYUNDAI -Grand i10						
KIT CONTROL Y SELECTOR CAMBIOS	3849 HYUCC	Grand i10 Sedan 2013... T/Standar	L4 Cil. 1.2 L	43794-B4000	CC78	 A=1046mm/B=1020mm
EMBRAGUE	3846 HYUEM	Grand i10 Sedan 2013...	L4 Cil. 1.2 L	41510-B4000	EM141	 1130mm
FRENO DE MANO	3848 HYUFP	Grand i10 2013-2017	L4 Cil. 1.2 L	59760B4000	FP391 Trasero Izquierdo	 1498mm
	3847 HYUFP	Grand i10 2013-2017	L4 Cil. 1.2 L	59770B4000	FP390 Trasero Derecho	 1564mm
HYUNDAI - i10 (DODGE)						
KIT CONTROL Y SELECTOR CAMBIOS	3575 HYUCC	i10 2009-2014 T/Standar	0	437940X001	CC52	 A=1078mm/B=1022mm
CONTROL CAMBIOS (Transversal)	3575CM HYUCC	i10 2009-2014 T/Estándar	L4 CIL. 1.6L	437940X001	CC52-C	 B=1022mm
SELECTOR CAMBIOS (Selector)	3575SM HYUCC	i10 2009-2014 T/Estándar	L4 CIL. 1.6L	437940X001	CC52-S	 A=1078mm
EMBRAGUE	3572 HYUEM	i10 2009-2014	L4 Cil. 1.1 L	415100X000	EM133	 828mm
FRENO DE MANO	3857 HYUFP	i10 2011- 2016	L4 Cil. 1.0 L	5977022110	FP387 Trasero Derecho	 1438mm
	3858 HYUFP	i10 2011- 2016	L4 Cil. 1.0 L	597600X930	FP388 Trasero Izquierdo	 1430mm
ACELERADOR	3160 HYUAC	i10 2009-2014	L4 Cil. 1.1 L	327900X000	AC140	 2645mm
ABERTURA	3161 HYUCA	i10 2009-2014	L4 Cil. 1.1 L	811900X100	CP9	 1130mm

Encino 1287 col. del Fresno Guadalajara Jal.







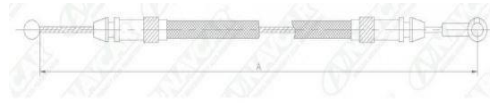

Tel. Multilínea (33) 3811 6917 - Servi-Cliente Cel. 33 1992 6768 - Guadalajara, Jalisco
Correo: ventas@flexcontrol.com.mx - www.flexcontrol.com.mx - www.cablesnavcar.com

Automóvil - Suv - Van - Pickup - Camiones Pesados - Ligeros

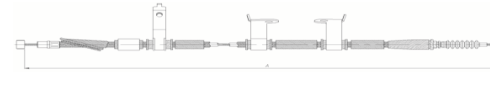
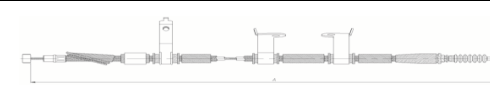
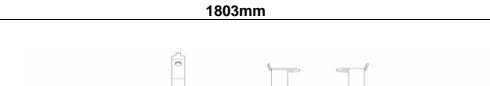
IMPORTANTE. Evite devoluciones o reclamos. Identifique previamente: marca, modelo y año del vehículo. En caso de duda, **CONSULTE** a su asesor.

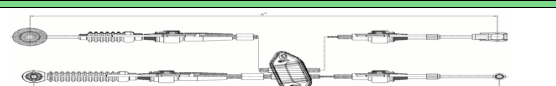
NUESTRA MISIÓN... Ser su aliado en el desarrollo y crecimiento de su negocio

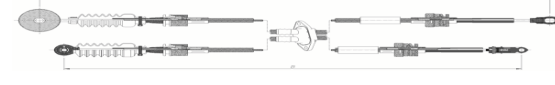
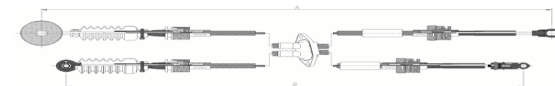
Competimos directamente con los ORIGINALES



LINEA	CODIGO	MODELO	MOTOR	O.E.M	ARMADO	IMAGEN -- LONGITUD
APERTURA COFRE	3839 HYUCA	i10 2007	L4 Cil. 1.0 L	81190-0X100	CP32 Segundo Tramo Corto	 540mm
HYUNDAI - HD65-HD72						
FRENO DE MANO	4001 HYUFP	HD 65 HD 72 2010...	4.0L	59910-5H100	FP412	 3565mm
HYUNDAI - TUCSON						
KIT CONTROL Y SELECTOR CAMBIOS	3689 HYUCC	Tucson Traccion 2R Traccion 4x4 2004-2009 T/Estándar	0	43794-2E000	CC51	 A=1252mm/B=1219mm
FRENO DE MANO	3229 HYUFP	Tucson SE 2005-2009	L4 Cil. 2.0 L V6 Cil. 2.7 L	597602E200	FP177 Trasero Izquierdo	 1710mm
	3228 HYUFP	Tucson SE 2005-2009	L4 Cil. 2.0 L V6 Cil. 2.7 L	597702E200	FP177 Trasero Derecho	 1803mm
	3229 HYUFP	Tucson Límited GLS, LX, GL 2005-2009	L4 Cil. 2.0 L V6 Cil. 2.7 L	597602E200	FP177 Trasero Izquierdo	 1710mm
FRENO DE MANO	3228 HYUFP	Tucson Límited GLS, LX, GL 2005-2009	L4 Cil. 2.0 L V6 Cil. 2.7 L	597702E200	FP177 Trasero Derecho	 1803mm
HYUNDAI - VERNA						
KIT CONTROL Y SELECTOR CAMBIOS	2483 HYUCC	Verna 2000... T/Standar	0	4379425200	CC11	 A=1218mm/B=1160mm
ACELERADOR	3499 HYUAC	Verna 2000 - 2006	L4 Cil. 1.5 L 1.6 L	3279025105	AC210	 1454mm
HYUNDAI - VISION						
KIT CONTROL Y SELECTOR CAMBIOS	2966 HYUCC	Vision 2006 T/Standar	0	437941G100	CC34	 A=1133mm/B=1256mm
	3389 KIACC	Vision Fase I T/Standar	0	4379407100 437942E000	CC34	 A=1096mm/B=1150mm
CONTROL CAMBIOS (Transversal)	2966CM HYUCC	Vision 2006 T/Standar	0	437941G100	CC34-C	 A=1133mm

Automóvil - Suv - Van - Pickup - Camiones Pesados - Ligeros

IMPORTANTE. Evite devoluciones o reclamos. Identifique previamente: marca, modelo y año del vehículo. En caso de duda, **CONSULTE** a su asesor.

NUESTRA MISIÓN... Ser su aliado en el desarrollo y crecimiento de su negocio

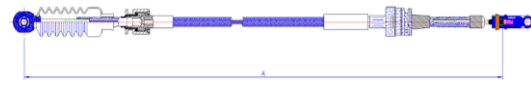
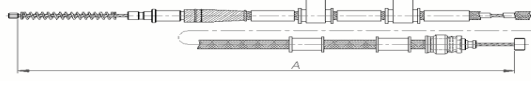
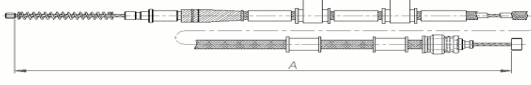
Competimos directamente con los ORIGINALES

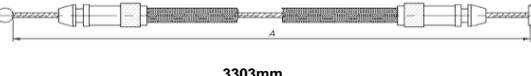
LINEA	CODIGO	MODELO	MOTOR	O.E.M	ARMADO	IMAGEN -- LONGITUD
SELECTOR CAMBIOS (Selector)	2966SM HYUCC	Vision 2006 T/Standar	0	437941G100	CC34-S	 B=1256mm
FRENO DE MANO	2643 HYUFP	Vision 2006-2011	L4 Cil. 1.5 L 1.6 L	597601G000	FP203 Trasero Izquierdo	 1604mm
	2644 HYUFP	Vision 2006-2011	L4 Cil. 1.5 L 1.6 L	597701G000	FP203 Trasero Derecho	 1604mm
ACELERADOR	2641 HYUAC	Vision 2006...	L4 Cil. 1.5 L 1.6 L	327901G000	AC211	 1129mm
APERTURA CAJUELA	2597 HYUAB	Vision 2006...	V6 Cil. 2.7 L V8 Cil. 4.7 L	0	AB2	 3303mm

INFINITI

INFINITI - i30

FRENO DE MANO	3670 NISFP	i30 1995-1999	V6 Cil. 3.0 L	36531-1L000 36531-1L005 36531-31U00	FP352 Trasero Izquierdo	 1684mm
---------------	---------------	------------------	------------------	---	----------------------------	--

INFINITI - G20

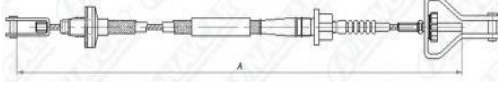
EMBRAGUE	3589 INFEM	G20 1991-1995	L4 Cil. 2.0L	30770-62J10 30770-62J01	EM41 Ref tubo int Nylon	 749mm
----------	---------------	------------------	-----------------	----------------------------	----------------------------	---

INFINITI - QX4

ACELEADOR	3485 NISAC	QX4 1996-1999	V6 Cil. 3.3 L	182010W000	AC250 Ref tubo Int Nylon	 1992mm
-----------	---------------	------------------	------------------	------------	-----------------------------	--

INTERNATIONAL

INTERNATIONAL - DINA

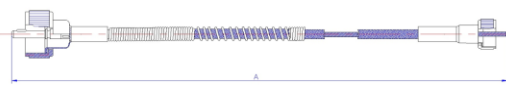
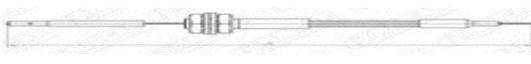





VELOCIMETRO	4049 DINVZ	Dina, International, Perkins, Kenwhort 1980 - 2005	0	0	VZ104	 1164mm
APAGADOR	1090 INTA	Dina Motor 408 466	1	2007021C91	AP2	 1176mm

Automóvil - Suv - Van - Pickup - Camiones Pesados - Ligeros

IMPORTANTE. Evite devoluciones o reclamos. Identifique previamente: marca, modelo y año del vehículo. En caso de duda, **CONSULTE** a su asesor.

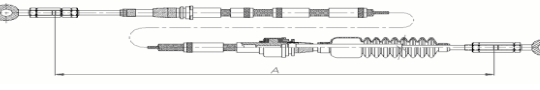
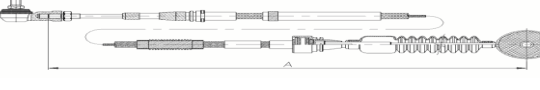
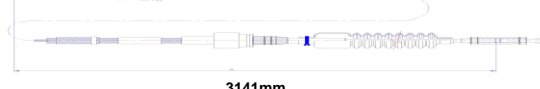
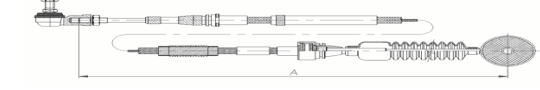
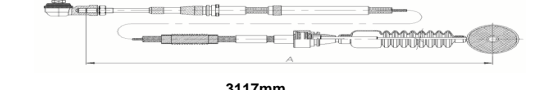
NUESTRA MISIÓN... Ser su aliado en el desarrollo y crecimiento de su negocio

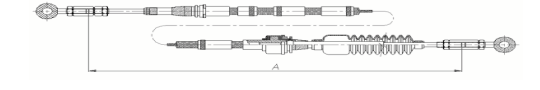
Competimos directamente con los ORIGINALES

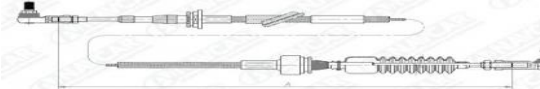
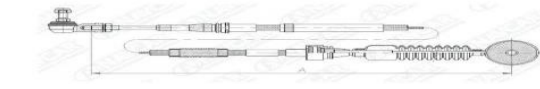
LINEA	CODIGO	MODELO	MOTOR	O.E.M	ARMADO	IMAGEN -- LONGITUD
ISUZU						
ISUZU - AMIGO						
EMBRAGUE	332 LUVÉ	Amigo 1988-1995	L4 Cil. 2.3 L	8943340823	EM162	 1670mm
	1845 ISUEM	Amigo 1989 - 1993	L4 Cil. 2.3 L	8943340820	EM5	 1647mm
ISUZU - ELF						
SELECTOR CAMBIOS (Selector)	3535 NKRSC	ELF 200 /300 4JJ1-TC 2009-2016 T/Standar	L4 Cil. 3.0 L	8980217002	SC21	 3046mm
CONTROL CAMBIOS (Transversal)	3536 NKRCC	ELF 200 /300 4JJ1-TC, 2009-2016 T/Estándar	L4 Cil. 3.0 L	8981468251	CC1	 3011mm
SELECTOR CAMBIOS (Selector)	3763 GMCSC	ELF 400 450 2006-2008 T/Standar	L4 Cil. 5.2 L	8973571824	SC74	 3141mm
CONTROL CAMBIOS (Transversal)	3762 GMCCC	ELF 400 450 2006-2008 T/Estándar	L4 Cil. 5.2 L	8981468500	CC1	 3105mm
CONTROL CAMBIOS (Transversal)	3855 GMCCC	ELF 400, 500, 600 Motor 4HK1 TC 2009 - 2016 T/Estándar	L4 Cil. 5.2 L	8-98146879-0 8-97357181-3	CC1	 3117mm
CONTROL CAMBIOS (Transversal)	3873 GMCCC	Elf 500 2012...	0	8980413813 8980413815 4CT2557	CC46	 3035mm
SELECTOR CAMBIOS (Selector)	3856 GMCSC	ELF 400, 500, 600 Motor 4HK1 TC 2009 - 2016 T/Standar	L4 Cil. 5.2 L	8-98025446-5	SC21	 3200mm
FRENO DE MANO	3877 GMCFP	ELF 400 -500 2011...	0	8980609963	FP171	 4014mm
CONTROL CAMBIOS (Transversal)	3873 GMCCC	Isuzu 2012... T/Estándar	0	8980413813 8980413815	CC46	 3035mm
ISUZU - NPR						
CONTROL CAMBIOS (Transversal)	1521 NPRC	NPR 729 4HG1 1999-2004 T/Estándar	0	0	CC1	 2954mm
ISUZU - FVR						

Encino 1207 col. del Fresno Guadalajara Jal.

Tel. Multilínea (33) 3811 6917 - Servi-Cliente Cel. 33 1992 6768 - Guadalajara, Jalisco
Correo: ventas@flexcontrol.com.mx - www.flexcontrol.com.mx - www.cablesnavcar.com

Automóvil - Suv - Van - Pickup - Camiones Pesados - Ligeros

IMPORTANTE. Evite devoluciones o reclamos. Identifique previamente: marca, modelo y año del vehículo. En caso de duda, **CONSULTE** a su asesor.

NUESTRA MISIÓN... Ser su aliado en el desarrollo y crecimiento de su negocio

Competimos directamente con los ORIGINALES

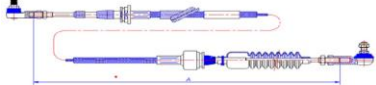
LINEA	CODIGO	MODELO	MOTOR	O.E.M	ARMADO	IMAGEN -- LONGITUD
SELECTOR CAMBIOS (Selector)	4257 ISUCC	FVR EUROII 2013-2022 DIESEL	7.8L	898178343-3 8981783432 8981503360 8981503362	CC46	 3605mm
CONTROL CAMBIOS (Transversal)	4256 ISUCC	FVR EUROII 2013-2022 DIESEL	7.8L	898178343-3 8981783432 8981503360 8981503362	CC46	 3412mm



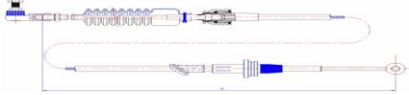
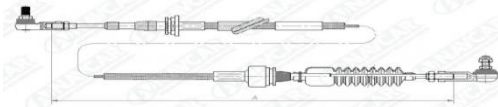

ISUZU - FRR FORWARD

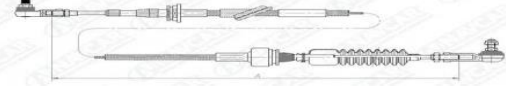
SELECTOR CAMBIOS (Selector)	4173 ISUSC	Isuzu Frr Forward 2012...	0	890413874	SC126	 3130mm
CONTROL CAMBIOS (Transversal)	4254 ISUCC	Isuzu Frr Forward Euro IV 2014...	0	8981672372	CC46	 2976mm

ISUZU - FSR

CONTROL CAMBIOS (Transversal)	2030 ISUCC	FSR 6HE1 +C1628 2006-2011 T/Estándar	0	1336711330	SC35	 3440mm
-------------------------------	----------------------	---	---	------------	------	--

ISUZU - LUV

EMBRAGUE	106 LUV	Luv 1980- 1986	1.6L	8942511841	EM5	 1611mm
	1843 GMCEM	Luv Gasolina - Diesel 1981-1986	L4 Cil. 2.3 L	8942514681 8942514682	EM5	 1655mm
	1398 LUV	Luv TFR6 - TFS6 1986 - 1988	L4 Cil. 2.3 L	8942381841	EM5	 1573mm
	332 LUV	Luv 1987 - 1992	L4 Cil. 2.3 L	8943340823	EM162	 1670mm
EMBRAGUE	1845 ISUEM	Luv 1988 - 1995	L4 Cil. 2.3 L	8943340820	EM5	 1647mm

ISUZU - LUV 2300 4x2

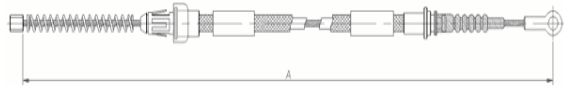
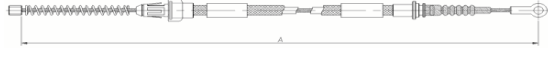
FRENO DE MANO	2105 GMCFP	Luv 2300 4x2 Doble cabina ...1988	L4 Cil. 1.6 L 2.3 L	94434619	FP23 Trasero Izquierdo	 1610mm
	2104 GMCFP	Luv 2300 4x2 Doble cabina ...1988	L4 Cil. 1.6 L 2.3 L	94434618	FP23 Trasero Derecho	 1685mm

Automóvil - Suv - Van - Pickup - Camiones Pesados - Ligeros

IMPORTANTE. Evite devoluciones o reclamos. Identifique previamente: marca, modelo y año del vehículo. En caso de duda, **CONSULTE** a su asesor.

NUESTRA MISIÓN... Ser su aliado en el desarrollo y crecimiento de su negocio



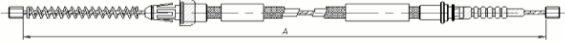
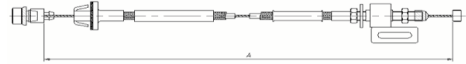
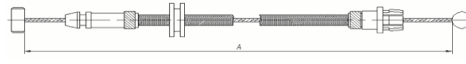

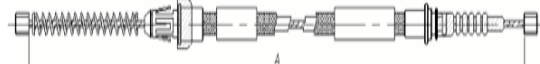
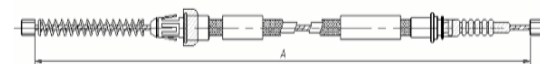

Competimos directamente con los ORIGINALES

LINEA	CODIGO	MODELO	MOTOR	O.E.M	ARMADO	IMAGEN -- LONGITUD
	973 LUVF	Luv 2300 4x2 1988...	L4 Cil. 1.6 L 2.3 L	8943667702	FP22 Trasero Izquierdo	 1609mm
ACELERADOR	941 LUVA	Luv 2300 1989...	L4 Cil. 1.4 L 1.6 L	8944733773	AC10	 696mm
APERTURA COFRE	335 LUVF	Luv 2300 1989...	V6 Cil. 3.7 L V8 Cil. 4.7 L	942225661	CP3 Sin Manija	 1968mm

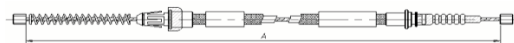
ISUZU - LUV 2300 4x4

FRENO DE MANO	582 LUVF	Luv 2300 Doble cabina 1989...	L4 Cil. 1.6 L 2.3 L	94366774	FP22 Trasero Izquierdo	 1609mm
	583 LUVF	Luv 2300 Doble cabina 1989...	L4 Cil. 1.6 L 2.3 L	94366773	FP22 Trasero Derecho	 1692mm

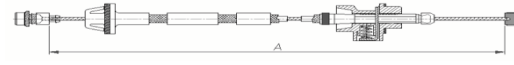
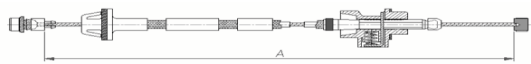
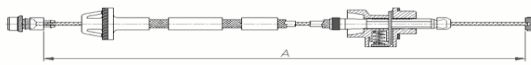
ISUZU - LUV D-MAX /COLORADO

FRENO DE MANO	2531 GMCFP	Luv D-Max Traccion 2R Traccion 4x4 Doble Cabina 2004...	V6 Cil. 3.5 L	8973633460	FP22 Trasero Izquierdo	 2015mm
	2532 GMCFP	Luv D-Max Traccion 2R Traccion 4x4 Cabina 2004...	V6 Cil. 3.5 L	8973680690	FP22 Trasero Derecho	 1987mm
	2923 GMCFP	Luv D-Max (Colorado)4x4 Diesel Cabina Doble; 4x2 HEC Cabina Doble / Cabina Sencilla 2004-2011	L4 Cil. 2.4 L V6 Cil. 3.0 L	95625136 / 95625134	FP343 Trasero Derecho	 1955mm
FRENO DE MANO	2924 GMCFP	Luv D-Max (Colorado)4x4 Diesel Cabina Doble; 4x2 Diesel Cabina Sencilla 2004-2011	L4 Cil. 2.4 L V6 Cil. 3.0 L	95625133 95625135	FP343 Trasero Izquierdo	 1956mm
ACELERADOR	2637 GMCAC	Luv D-Max (Colorado) Gasolina 2005...	V6 Cil. 3.5 L	8973159651	AC218	 912mm
	2636 GMCAC	Luv D-Max (Colorado)4x2 Gasolina 2005...	L4 Cil. 2.4 L	8973629490	AC218	 890mm
	2551 GMCAC	Luv D-Max (Colorado) Traccion 2R Diesel Cab Simple 2005...	L4 Cil. 2.5 L	8973690080	AC218	 578mm
	2648 GMCAC	Luv D-Max Traccion 2R Traccion 4x4 Diesel 2005...	V6 Cil. 3.0 L	8973159682	AC221	 1150mm

Encino 1287 col. del Fresno Guadalajara Jal.

Tel: Multilínea (33) 3811 6917 - Serv. Cliente Cel: 33 1992 6768 - Guadalajara, Jalisco
Correo: ventas@flexcontrol.com.mx - www.flexcontrol.com.mx - www.cablesnavcar.com

Automóvil - Suv - Van - Pickup - Camiones Pesados - Ligeros

IMPORTANTE. Evite devoluciones o reclamos. Identifique previamente: marca, modelo y año del vehículo. En caso de duda, **CONSULTE** a su asesor.

NUESTRA MISIÓN... Ser su aliado en el desarrollo y crecimiento de su negocio

Competimos directamente con los ORIGINALES

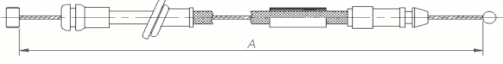
LINEA	CODIGO	MODELO	MOTOR	O.E.M	ARMADO	IMAGEN -- LONGITUD
APERTURA COFRE	2578 GMCCA	Luv D-Max (Colorado) 2007	V6 Cil. 2.7 L V8 Cil. 4.7 L	8973344362	CP19	 1905mm

ISUZU - LUV KB-20

EMBRAGUE	1395 LUVÉ	Luv KB20-25 1978 - 1980	L4 Cil. 2.3 L	5314250130 94028795 940271 92	EM5	 1546mm
----------	---------------------	-------------------------------	------------------	-------------------------------------	-----	--

ISUZU - LUV KB-21

ACELERADOR	104 LUVA	Luv KB-21-46 1980 - 1986	L4 Cil. 2.4 L	8942225532	AC11	 646mm
------------	--------------------	--------------------------------	------------------	------------	------	---

ISUZU - LUV TFR

EMBRAGUE	1397 LUVÉ	Luv TFR6 - TFS6; Truck Traccion 2R 1986 - 1988	L4 Cil. 2.3 L	8941609293 8944080201	EM5	 1576mm
----------	---------------------	---	------------------	--------------------------	-----	--

ISUZU - LV 150

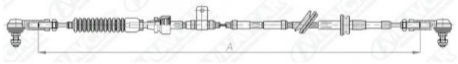
SELECTOR CAMBIOS (Selector)	2528 GMCSC	LV-150 2001-2012 T/Standar	0	1336715301	SC41	 8205mm
-----------------------------	----------------------	----------------------------------	---	------------	------	--

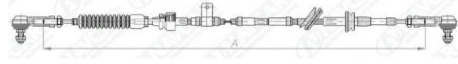
CONTROL CAMBIOS (Transversal)	2527 GMCCC	LV-150 2001-2012 T/Standar	0	1336715291	SC41	 8244mm
-------------------------------	----------------------	----------------------------------	---	------------	------	--

ISUZU - TROOPER

EMBRAGUE	2111 ISUEM	Trooper Gas 1984 - 1986	L4 Cil. 2.8 L	8941823530	EM5	 1685mm
----------	----------------------	-------------------------------	------------------	------------	-----	--

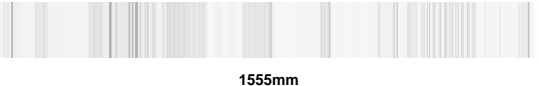
EMBRAGUE	1396 TROE	Trooper UBS 13-16 1984 - 1986	L4 Cil. 2.8 L	8942381853	EM5	 1555mm
----------	---------------------	-------------------------------------	------------------	------------	-----	--

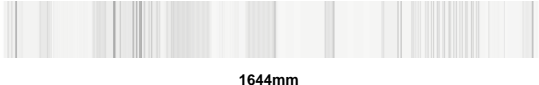
	1394 TROE	Trooper UBS 5-6 1986 - 1991	L4 Cil. 2.8 L	8944605042	EM161	 1644mm
--	---------------------	-----------------------------------	------------------	------------	-------	--

JAC

JAC - Truck

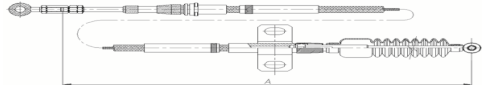
SELECTOR CAMBIOS (Selector)	2431 JACSC	Jac 1050,1060,1063... 2006-2012 T/Standar	L4 Cil. 2.8 L	1703030E0BB	SC39	 3016mm
-----------------------------	----------------------	--	------------------	-------------	------	--

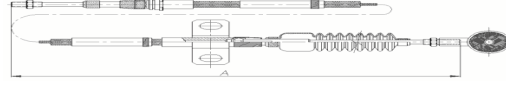

CONTROL CAMBIOS (Transversal)	2430 JACCC	Jac 1050,1060,1063... 2006-2012 T/Standar	L4 Cil. 2.8 L	1703040E0BB	CC24	 2948mm
-------------------------------	----------------------	--	------------------	-------------	------	--

Automóvil - Suv - Van - Pickup - Camiones Pesados - Ligeros

IMPORTANTE. Evite devoluciones o reclamos. Identifique previamente: marca, modelo y año del vehículo. En caso de duda, **CONSULTE** a su asesor.

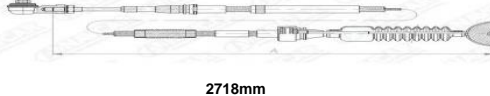
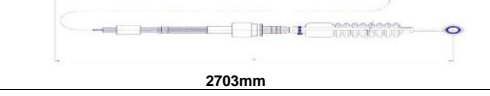
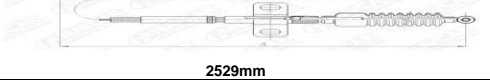

NUESTRA MISIÓN... Ser su aliado en el desarrollo y crecimiento de su negocio

Competimos directamente con los ORIGINALES

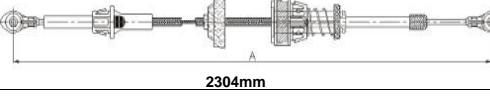
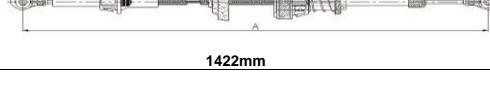

LINEA	CODIGO	MODELO	MOTOR	O.E.M	ARMADO	IMAGEN -- LONGITUD
CONTROL CAMBIOS (Transversal)	3764 JACCC	Bus Jac 6900 Diesel Cummins ISF S3168 2013-2015 T/Estándar	L4 Cil. 3.8 L	1703040K3240	CC58	 2658mm
SELECTOR CAMBIOS (Selector)	4008 JACSC	JAC 1047 City Star 2013-2018 T/Estándar	3.8 L	1703200LE190	SC66	 2965mm
CONTROL CAMBIOS (Transversal)	3913 JACCC	Jac HFC 1020,1040, 1048, 1083, 304, 3048 2007-2014 T/Estándar	3.8 L	1703040B1	CC81	 2847mm
CONTROL CAMBIOS (Transversal)	3977 JACCC	JAC 1047 City Star Clase 2013-2018 T/Estándar	3.8 L	1703300EL1	CC1	 2718mm
SELECTOR CAMBIOS (Selector)	3765 JACSC	Bus Jac 6900 Diesel Cummins ISF S3168 2013-2015 T/Standar	L4 Cil. 3.8 L	1703030K3240	SC73	 2703mm
SELECTOR CAMBIOS (Selector)	3806 JACSC	Jac 1061KN Diesel Cummins ISF S3168 2013 - 2015	3.8L	0	SC39	 2529mm

JEEP (AMC)

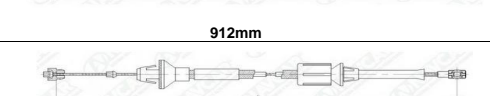
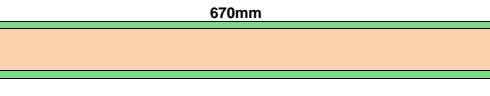
JEEP - CHEROKEE

SELECTOR CAMBIOS	3582 AMCSC	Cherokee 1988-1990 T/Automática	L4 Cil. 2.5 L	53004561	SC67	 2304mm
	3583 AMCSC	Cherokee 1986-1992 T/Automática	L4 Cil. 2.5 L V6 Cil. 4.0 L	53004562	SC67	 1422mm
FRENO DE MANO	2599 JEEFP	Cherokee 1991-1998	0	0	FP239Trasero Derecho/ Izquierdo	 1317mm
ACELERADOR	3766 JEEAC	Cherokee 1984 - 1987	0	53000038	AC261	 912mm
	1531 JEEA	Cherokee 1988 - 1990	V6 Cil. 4.0 L	53005245	AC138	 670mm

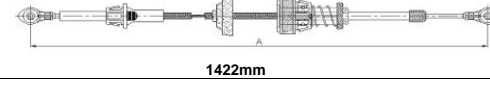
JEEP - COMANCHE

SELECTOR CAMBIOS	3583 AMCSC	Comanche 1986-1992 T/Automática	L4 Cil. 2.5 L V6 Cil. 4.0 L	53004562	SC67	 1422mm
ACELERADOR	3766 JEEAC	Comanche 1984 - 1987	0	53000038	AC261	 912mm

Automóvil - Suv - Van - Pickup - Camiones Pesados - Ligeros

IMPORTANTE. Evite devoluciones o reclamos. Identifique previamente: marca, modelo y año del vehículo. En caso de duda, **CONSULTE** a su asesor.

NUESTRA MISIÓN... Ser su aliado en el desarrollo y crecimiento de su negocio



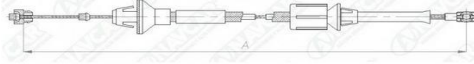

Competimos directamente con los ORIGINALES

LINEA	CODIGO	MODELO	MOTOR	O.E.M	ARMADO	IMAGEN -- LONGITUD
ACELERADOR	1531 JEEA	Comanche 1988 - 1990	V6 Cil. 4.0 L	53005245	AC138	 670mm

JEEP - COMPASS

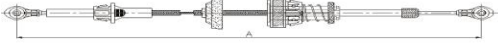
SELECTOR CAMBIOS (Selector)	4199 JEESC	Compass 2007-2017 T/Estándar	2.4L	68024433AD	SC131	 1171mm
FRENO DE MANO	3730 DODFP	Compass 2007 - 2013	L4 Cil. 2.0 L 2.4 L	4877016AB 04877016AC 04877016AA 05105140AB 05105140AC 05105140AD	FP364 Trasero Derecho	 1575mm

JEEP - GRAND CHEROKEE

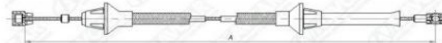
SELECTOR CAMBIOS	3582 AMCSC	Grand Cherokee 1988-1992 T/Automática	L4 Cil. 2.5 L	53004561	SC67	 2304mm
	2752 AMCSC	Grand Cherokee 1993 - 1998 T/Automática	L4 Cil. 2.5 L	52104095	SC29	 1098mm
FRENO DE MANO	3705 JEEFP	Grand Cherokee 1999 - 2004	V8Cil. 4.0L 4.7L	52128243AD	FP357	 867mm
SOBREMARCHA	3710 DODSB	Grand Cherokee 1998	0	52104030A	SB36	 1566mm
	3712 CHR SB	Grand Cherokee Traccion 2R Traccion 4x4 1999-2004	0	52104284AB	SB36	 2003mm
ACELERADOR	3706 JEEAC	Grand Cherokee Traccion 4x4 1999 - 2004	V6Cil. 4.0 L	52079504	AC79	 1263mm

JEEP - JAVELIN

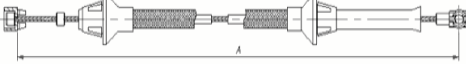
ACELERADOR	1862 AMCAC	Javelin Classic 1972 - 1973	0	20090777	AC79	 853mm
------------	----------------------	--------------------------------	---	----------	------	---

JEEP - PATRIOT

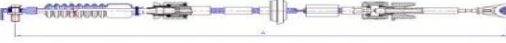
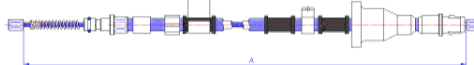
SELECTOR CAMBIOS (Selector)	4199 JEESC	Patriot 2007-2017 T/Estándar	2.4L	68024433AD	SC131	 1171mm
FRENO DE MANO	3730 DODFP	Patriot 2007 - 2013	L4 Cil. 2.0 L 2.4 L	4877016AB 04877016AC 04877016AA 05105140AB 05105140AC 05105140AD	FP364 Trasero Derecho	 1575mm

JEEP - RENEGADO

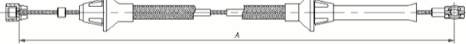







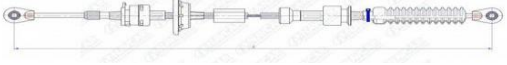

ACELERADOR	1704 JEEA	Renegado 1982 - 1984	0	J5357931	AC79	 445mm
------------	---------------------	-------------------------	---	----------	------	---

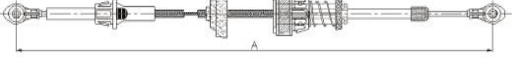
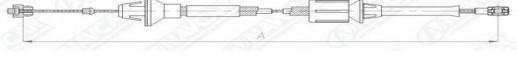
Automóvil - Suv - Van - Pickup - Camiones Pesados - Ligeros

IMPORTANTE. Evite devoluciones o reclamos. Identifique previamente: marca, modelo y año del vehículo. En caso de duda, **CONSULTE** a su asesor.

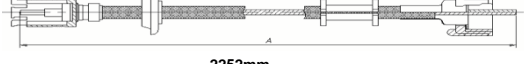
NUESTRA MISIÓN... Ser su aliado en el desarrollo y crecimiento de su negocio

Competimos directamente con los ORIGINALES

LINEA	CODIGO	MODELO	MOTOR	O.E.M	ARMADO	IMAGEN -- LONGITUD
SELECTOR CAMBIOS (Selector)	3883 CHRCC	Rubicon 6 velocidades 2007-2018 T/Estandar	V6 Cil. 3.8L	5226222AC	CC64	 912mm
SELECTOR PARA TRANSFER 4X4	4129 JEESC	Rubicon 4 velocidades 2007-2011 para T/Automática	V6 Cil. 3.8L	52060462AG	SC116	 1044mm
JEEP - WAGONEER						
SELECTOR CAMBIOS	3582 AMCSC	Wagoneer 1988-1990 T/Automática	L4 Cil. 2.5 L	53004561	SC67	 2304mm
ACELERADOR	1531 JEEA	Wagoneer 1988 - 1990	V6 Cil. 4.0 L	53005245	AC138	 670mm
	3766 JEEAC	Wagoneer 1984 - 1987	0	53000038	AC261	 912mm
JEEP - WRANGLER						
SELECTOR CAMBIOS (Selector)	3883 CHRCC	Wrangler 6 velocidades para T/Estandar	V6 Cil. 3.8L	5226222AC	CC64	 912mm
SELECTOR PARA TRANSFER 4X4	4129 JEESC	Wrangler 4 velocidades 2007-2011 para T/Automática	V6 Cil. 3.8L	52060462AG	SC116	 1044mm
SELECTOR CAMBIOS	4228 JEESC	Wrangler 2007-2011 T/Automática	3.8L	52060164AD	SC136	 1135mm
VELOCIMETRO	721 AMCVZ	Wrangler (VJ) 1987 - 1989	V6 Cil. 4.0 L	53002506	VZ47	 2252mm
KIA						
KIA PICANTO						
KIT CONTROL Y SELECTOR CAMBIO	3964 KIACC	Picanto 2016-2017... T/Estandar	0	43794-1Y500,	CC78	 A=1116mm/B=1157mm
KIA NEW SPORTAGE						
KIT CONTROL Y SELECTOR CAMBIO	3939 KIACC	New Sportage 2010... T/Estandar	2.0L	0	CC72	 A=1249mm/B=1221mm
KIA - RIO						
KIT CONTROL Y SELECTOR CAMBIOS	3965 KIACC	Rio Stylus 2008-2016 T/Estandar	1.6L	437941-W200	CC50	 A=1233mm/B=1161mm

Encino 1287 col. del Fresno Guadalajara Jal.



Tel. Multilínea (33) 3811 6917 - Servi-Cliente Cel. 33 1992 6768 - Guadalajara, Jalisco
Correo: ventas@flexcontrol.com.mx - www.flexcontrol.com.mx - www.cablesnavcar.com

Automóvil - Suv - Van - Pickup - Camiones Pesados - Ligeros

¡IMPORTANTE! Evite devoluciones o reclamos. Identifique previamente: marca, modelo y año del vehículo. En caso de duda, **CONSULTE** a su asesor.



NUESTRA MISIÓN... Ser su aliado en el desarrollo y crecimiento de su negocio

Competimos directamente con los ORIGINALES

LINEA	CODIGO	MODELO	MOTOR	O.E.M	ARMADO	IMAGEN -- LONGITUD
EMBRAGUE	1952 KIAEM	Rio Sedan - Hardback 2003	L4 Cil. 1.6 L	0K30A-41-150C	EM24	 730mm
EMBRAGUE	3691 KIAEM	Rio Sedan 4Ptas, RX-V 5Ptas LA Wagon	1.5L 6.0L	OK31G41150D	EM139	 1166mm





MACK

MACK - TRUCK

EMBRAGUE	345 MACE	Mack 1978	0	FCQ2960078	EM52	 1981mm
EMBRAGUE	2470 MACEM	Mack 112	0	0	EM52	 2845mm

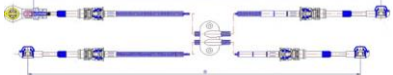
MAZDA

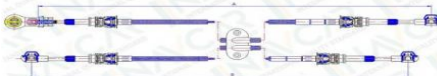
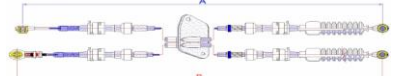
MAZDA - 2-3

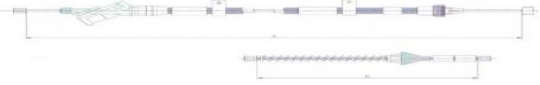



KIT CONTROL Y SELECTOR CAMBIOS	4201 MAZCC	Mazda 3 Hatchback 2005 - 2014 T/Estándar	0	BAK6-46-500	CC95	 A=1244mm/B=1280mm
	4051 MAZCC	Mazda 3 2005 - 2015 T/Estándar	1.6L	BP4K-46-500	CC95	 A=1182mm/B=1221mm
	4139 MAZCC	Mazda 3 2005 - 2014 T/Estándar	2.0L	BP4S-46-500F	CC95	 A=1238mm/B=1272mm
	4162 MAZCC	Mazda 3 2010-2015 T/ Estándar	2.5L	0	CC95	 A=1268mm/B=1302mm
FRENO DE MANO	3949 MAZFP	Mazda 2 2011..	1.5L	1211024 DA7H44400A	FP403 Traseros Derecho/ Izquierdo	 A=1328mm/B=1357mm
	3950 MAZFP	Mazda 2 2011-2015..	1.5L	DA7H44150	FP404 Principal	 407mm
	3941 MAZFP	Mazda 3 Sedan 2004 -2009	1.6L	BP4K44420E BP4K44420K,	FP400 Trasero Derecho	 1518mm

Automóvil - Suv - Van - Pickup - Camiones Pesados - Ligeros

IMPORTANTE. Evite devoluciones o reclamos. Identifique previamente: marca, modelo y año del vehículo. En caso de duda, **CONSULTE** a su asesor.

NUESTRA MISIÓN... Ser su aliado en el desarrollo y crecimiento de su negocio

Competimos directamente con los ORIGINALES

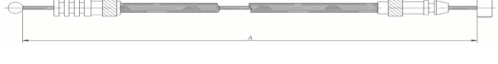
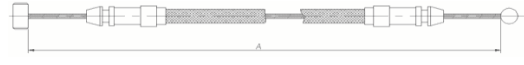
LINEA	CODIGO	MODELO	MOTOR	O.E.M	ARMADO	IMAGEN -- LONGITUD
	3942 MAZFP	Mazda 3 Sedan 2004 -2009	1.6L	BP4K44410	FP400 Trasero Izquierdo	 1442mm
	3943 MAZFP	Mazda 3 Sedan 2004 -2009	2.0L 2.5L	BP4K44150B	FP401	 342mm
ACELERADOR	3374 MAZAC	Mazda 3 sedan 2009	L4 Cil. 1.6 L	0	AC241	 1801mm
	3556 MAZAC	Mazda 3 2010 - 2013	L4 Cil. 2.0 L	BP4T41660G	AC253	 1801mm
APERTURA CAJUELA	3462 MAZAB	Mazda 3 sedan 2009	L4 Cil. 1.6 L	0	AB1	 3944mm
APERTURA COFRE	3375 MAZCA	Mazda 3 sedan 2009	L4 Cil. 1.6 L	0	CP9	 1755mm

MAZDA - 5

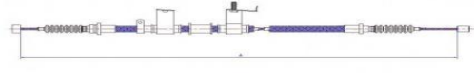
FRENO DE MANO	4102 MAZFP	Mazda 5 CR19-CW 2002-2010	2.0L	C23644420C C23644420D C23644420E C23644420F C23644420H	FP442 Trasero Izquierdo	 1825mm
---------------	----------------------	---------------------------------	------	--	-------------------------------	--

MAZDA - 6

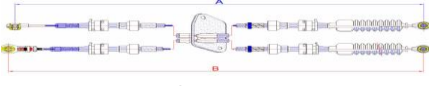
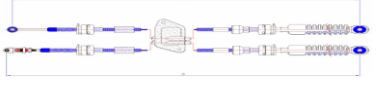
KIT CONTROL Y SELECTOR CAMBIOS	4383 MAZCC	Mazda 6 2007-2008	2.0L	G28J46500	CC143	 1306mm/1285mm
KIT CONTROL Y SELECTOR CAMBIOS	4360 MAZCC	Mazda 6 2004-2006	2.0L	GJ6A56500F	CC139	 1291mm/1252mm

MAZDA - 323

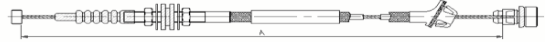
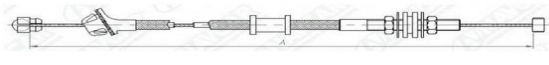
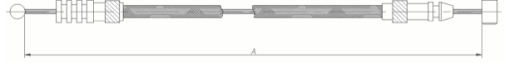
ACELERADOR	2557 MAZAC	323 full Injection	L4 Cil. 2.0 L	0	AC34	 1228mm
	249 MAZA	323 NX - NT NS - HS - HE 1986...	L4 Cil. 2.0 L	BF6741660B	AC33	 1078mm
APERTURA CAJUELA	245 MAZB	323 NX - NS 1986...	V6 Cil. 2.7 L V8 Cil. 4.7 L	8COB56016A	AB1	 3340mm

MAZDA - B2000 - B2200

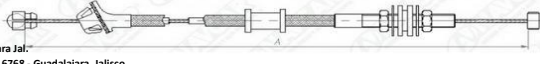
	379 MAZA	B2000, B2200 1987...	L4 Cil. 2.2 L 2.6 L	UB3941660B	AC33	 685mm
--	--------------------	-------------------------	---------------------------	------------	------	---

Automóvil - Suv - Van - Pickup - Camiones Pesados - Ligeros

IMPORTANTE. Evite devoluciones o reclamos. Identifique previamente: marca, modelo y año del vehículo. En caso de duda, **CONSULTE** a su asesor.

NUESTRA MISIÓN... Ser su aliado en el desarrollo y crecimiento de su negocio

Competimos directamente con los ORIGINALES

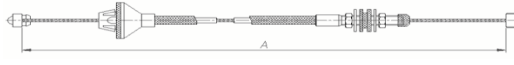
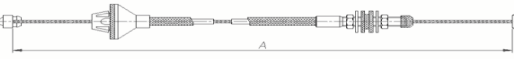
LINEA	CODIGO	MODELO	MOTOR	O.E.M	ARMADO	IMAGEN -- LONGITUD
ACELERADOR	2230 MAZAC	B2200 fuel injection	L4 Cil. 2.2 L 2.6 L	0	AC179	 1228mm
	2229 MAZAC	B2200 fuel injection 1990	L4 Cil. 2.2 L 2.6 L	0	AC179	 757mm

MAZDA - B2600

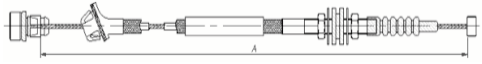
ACELERADOR	436 MAZA	B2600 1993 - 1997	L4 Cil. 2.2 L 2.6 L	UE4641660A	AC34	 777mm
------------	--------------------	----------------------	---------------------------	------------	------	---

MAZDA - BT-50

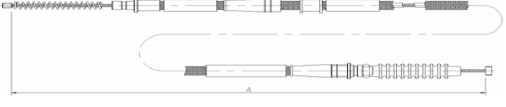
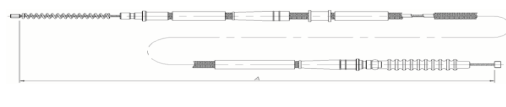
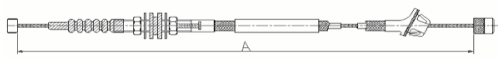
FRENO DE MANO	2654 MAZFP	BT-50 Traccion 4x4 2008 -2015	L4 Cil. 2.5 L	UR6144420A	FP493 Trasero Izquierdo	 3098mm
	2655 MAZFP	BT-50 Traccion 4x4 2008-2015	L4 Cil. 2.5 L	UR6144410	FP494 Trasero Derecho	 2267mm
ACELERADOR	2652 MAZAC	BT-50 Traccion 4x4 Gasolina 2006...	L4 Cil. 2.5 L	UJ1041660A	AC222	 739mm

MAZDA - MPV

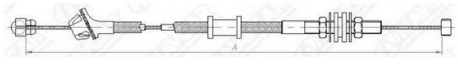

ACELERADOR	2320 MAZAC	MPV 2600 1989 - 1994	L4 Cil. 2.6 L	LA0841660B	AC34	 845mm
------------	----------------------	----------------------------	------------------	------------	------	---

MAZDA - PICKUP

ACELERADOR	321 MAZA	Mazda 626 1986-1992	L4 Cil. 2.6 L	BF8141660C	AC33	 1215mm
------------	--------------------	---------------------------	------------------	------------	------	--

MERCURY

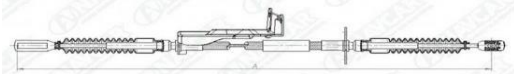
MERCURY - CAPRI

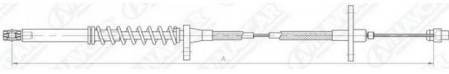
SELECTOR CAMBIOS	3168 FORSC	Capri 40D 1984-1993 T/Automática	L4 Cil. 2.3 L V6 Cil. 3.8 L 5.0 L	E4ZZ-7E395A E6ZZ-7E395A	SC64	 1395mm
EMBRAGUE	3773 FOREM	Capri 1979	V8 Cil. 5.0 L	D9BZ-7K553-D D9ZZ 7K553-B	EM140	 1430mm
	1711 EFOE	Capri 1982 - 1986	5.0L V8	E4ZC7K553A	EM77	 1463mm
ACELERADOR	3606 FORAC	Capri 1983-1989	V8 Cil. 5.0 L	E2SZ-9A758-C	AC43	 487mm



MERCURY GRAND MARQUIS

Automóvil - Suv - Van - Pickup - Camiones Pesados - Ligeros



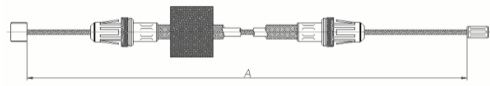

IMPORTANTE. Evite devoluciones o reclamos. Identifique previamente: marca, modelo y año del vehículo. En caso de duda, **CONSULTE** a su asesor.

NUESTRA MISIÓN... Ser su aliado en el desarrollo y crecimiento de su negocio



Competimos directamente con los ORIGINALES

LINEA	CODIGO	MODELO	MOTOR	O.E.M	ARMADO	IMAGEN -- LONGITUD
FRENO DE MANO	2826 FORFP	Grand Marquis 2003 - 2004	V6 Cil. 4.6 L	0	FP459 Principal	 1400mm
VELOCIMETRO	3052 FORVZ	Grand Marquis 1960-1981	0	B9MF17260-B, C0MF17260-A, C6DZ17260-B	VZ84	 1707mm

MERCURY - MARQUIS

EMBRAGUE	1710 EFOE	Marquis 1983	L6 Cil. 3.3 L V8 Cil. 4.2 L	D9BZ7K553F	EM75	 1020mm
VELOCIMETRO	3052 FORVZ	Marquis 1960-1981	0	B9MF17260-B, C0MF17260-A, C6DZ17260-B	VZ84	 1707mm
ACELERADOR	396 EFOA	Marquis Motor 302 1980	V8 Cil. 5.0 L	E0AZ9A758A	AC42	 750mm
	3606 FORAC	Marquis 1983-1989	V8 Cil. 5.0 L	E2SZ-9A758-C	AC43	 487mm
VELOCIMETRO	2700 FORVZ	Marquis Traccion 4x4 1983 - 1998	V8 Cil. 4.6 L	E3BZ9A820A	VZ88	 1854mm

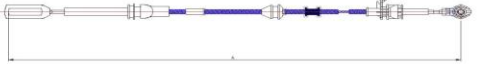
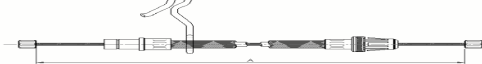
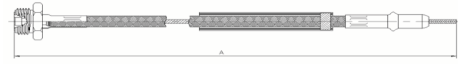
MERCURY - SABLE

SELECTOR CAMBIOS	4067 FORSC	Sable 2003-2004 T/Automática	0	4F1Z-7E395-AA	SC110	 1067mm
SELECTOR CAMBIOS	4028 FORSC	Sable 2001-2004 T/Automática	V6 Cil. 3.0 L	6F1Z7E395A	SC101	 1023mm
FRENO DE MANO	2816 FORFP	Sable 1996 - 2007	V6 Cil. 3.0 L	F6DZ2A635BG	FP264 Trasero Izquierdo	 905mm
VELOCIMETRO	2842 FORVZ	Sable 1991-1998	V6 Cil. 3.0 L	F0DZ9F714A	VZ93 Tramo Inferior	 504mm
	2701 FORVZ	Sable 1980 - 1998	V8 Cil. 4.6 L	E6DZ9A820A	VZ88 Tramo Superior	 940mm
ACELERADOR	1590 EFOA	Sable 1981 - 1987	V6 Cil. 1.6 L 2.0 L 2.3 L 2.5 L	E2FZ9A758A	AC42	 1166mm



MERCURY - ZEPHYR

Automóvil - Suv - Van - Pickup - Camiones Pesados - Ligeros

IMPORTANTE. Evite devoluciones o reclamos. Identifique previamente: marca, modelo y año del vehículo. En caso de duda, **CONSULTE** a su asesor.

NUESTRA MISIÓN... Ser su aliado en el desarrollo y crecimiento de su negocio



Competimos directamente con los ORIGINALES

LINEA	CODIGO	MODELO	MOTOR	O.E.M	ARMADO	IMAGEN -- LONGITUD
EMBRAGUE	1710 EFOE	Zephyr Motor 200 1978	0	D9BZ7K553F	EM75	 1020mm
	3773 FOREM	Zephyr 1979	V8 Cil. 5.0 L	D9BZ-7K553-D D9ZZ 7K553-B	EM140	 1430mm

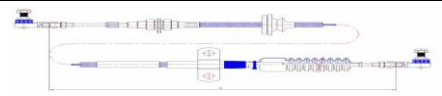
MERCEDES -FREIGHTLINER

CONTROL CAMBIOS (Transversal)	4177 MERCC	Freightliner Sterling 360 2008-2015	4.8 L	A400-260-1651	CC111	 3197mm
-------------------------------	----------------------	--	-------	---------------	-------	--

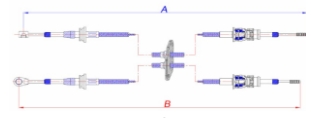
MERCEDES - SPRINTER

KIT CONTROL Y SELECTOR CAMBIOS	4346 MERCC	Sprinter 313-413 2000- 2013 T/Estanadar	2.0L	A9012601338	CC136	 A=1160mm/B=1018mm
FRENO DE MANO	4151 MERFP	Sprinter 313-413	2.0L	2D0609721 9014201885	FP462Trasero Derecho/Izquierdo	 1327mm

MITSUBISHI

MITSUBISHI - ECLIPSE

FRENO DE MANO	3683 MITFP	Eclipse 1988-1992	L4 Cil. 2.0 L	MB520483	FP351 Trasero Izquierdo	 1446mm
---------------	----------------------	----------------------	------------------	----------	-------------------------------	--

MITSUBISHI - FUSO

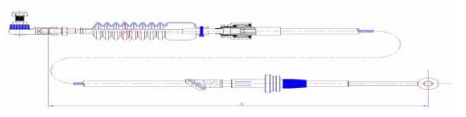
SELECTOR CAMBIOS	4169 MITSC	Fuso Canter 2007	0	MK603878	SC126	 2673mm
------------------	----------------------	---------------------	---	----------	-------	--

MITSUBISHI - GALANT

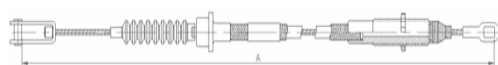
EMBRAGUE	1029 MITE	Galant 1980 - 1983	L4 Cil. 2.4 L	MB012117	EM42	 807mm
----------	---------------------	-----------------------	------------------	----------	------	---

MITSUBISHI - L200

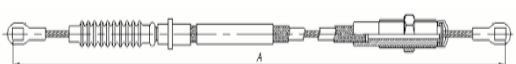
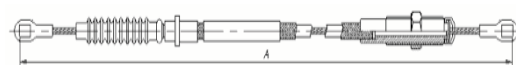
EMBRAGUE	871 MITE	L200 1986 - 1989	L4 Cil. 2.6 L	MB527073	EM43	 877mm
	874 MITE	L200 D50 1994...	L4 Cil. 2.6 L	MB598411	EM43	 870mm







MITSUBISHI - L300

Automóvil - Suv - Van - Pickup - Camiones Pesados - Ligeros

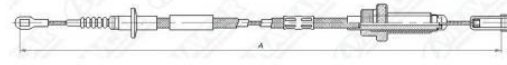
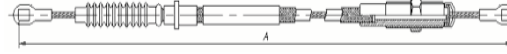
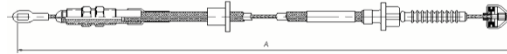
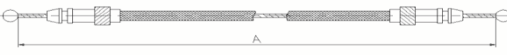
IMPORTANTE. Evite devoluciones o reclamos. Identifique previamente: marca, modelo y año del vehículo. En caso de duda, **CONSULTE** a su asesor.

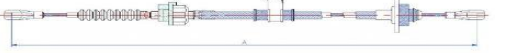
NUESTRA MISIÓN... Ser su aliado en el desarrollo y crecimiento de su negocio

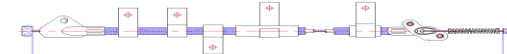
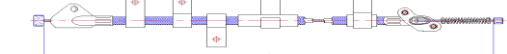
Competimos directamente con los ORIGINALES

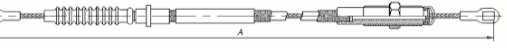
LINEA	CODIGO	MODELO	MOTOR	O.E.M	ARMADO	IMAGEN -- LONGITUD
EMBRAGUE	2477 MITEM	L-300 1999 - 2001	L4 Cil. 2.0 L	MR162914	EM44 Ref tubo int Nylon	 2175mm
MITSUBISHI - LANCER						
EMBRAGUE	87 MITE	Lancer 1988-1992	L4 Cil. 2.0 L 2.4 L	MB527334	EM43	 2039mm
	1756 MITEM	Lancer C82 1993...	L4 Cil. 2.0 L 2.4 L	MB912305	EM51	 1675mm
APERTURA COFRE	3723 MITAP	Lancer 2004-2008	0	0	ACH4	 1953mm
MITSUBISHI - MIRAGE						
KIT CONTROL Y SELECTOR CAMBIOS	4239 DODCC	Mirage G4 2014... T Estandar	L3 Cil 1.2L	2460A112	CC118	 A=1174mm/B=1114mm
EMBRAGUE	88 MITE	Mirage 1980....	L4 Cil. 1.5 L	MB012071	EM51 Ref tubo Int Nylon	 1358mm
	3963 MITEM	Mirage ES,GT 2014-2017 T/Standar	L4 Cil. 1.5 L	2342A019	EM145	 950mm
	1846 MITEM	Mirage 1986 - 1989	L4 Cil. 1.5 L	MB527467	EM51	 1388mm
MITSUBISHI - MONTERO						
FRENO DE MANO	3800 MITFP	Montero 1991 - 2004	2.5 L turbo diesel	MB520893	FP380 Trasero Derecho	 1485mm
	3801 MITFP	Montero 1991 - 2004	2.5 L turbo diesel	MB520892	FP380 Trasero Izquierdo	 1482mm
APERTURA COFRE	1946 MITCA	Montero 1982 - 1997	V6 Cil. 1.7 L V8 Cil. 4.7 L	MB021373	CP7	 1805mm
MITSUBISHI - RAM 50						
EMBRAGUE	1394 TROE	Ram 50 1986 - 91	L4 Cil. 2.6 L	8944605042	EM161	 1644mm
	1340 MITE	Ram 50 Traccion 2R 1979 - 1986	L4 Cil. 2.0 L 2.6 L	MB012460	EM43	 826mm

Encino 1287 col. del Fresno Guadalajara Jal.



Tel. Multilínea (33) 3811 6917 - Servi-Cliente Cel. 33 1992 6768 - Guadalajara, Jalisco
Correo: ventas@flexcontrol.com.mx - www.flexcontrol.com.mx - www.cablesnavcar.com

Automóvil - Suv - Van - Pickup - Camiones Pesados - Ligeros

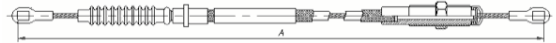

IMPORTANTE. Evite devoluciones o reclamos. Identifique previamente: marca, modelo y año del vehículo. En caso de duda, **CONSULTE** a su asesor.

NUESTRA MISIÓN... Ser su aliado en el desarrollo y crecimiento de su negocio

Competimos directamente con los ORIGINALES

LINEA	CODIGO	MODELO	MOTOR	O.E.M	ARMADO	IMAGEN -- LONGITUD
EMBRAGUE	1341 MITE	Ram 50 Traccion 4x4, Exc. Diesel 1981 - 1986	L4 Cil. 2.6 L	MB012475	EM43	 800mm
	874 MITE	Ram 50 1987-1993	L4 Cil. 2.6 L	MB598411	EM43	 870mm
ACELERADOR	2318 MITAC	Ram 50 2400T 1990 - 1996	L4 Cil. 2.3 L	MB539514	AC162	 1002mm

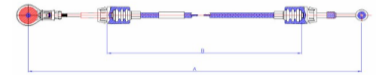
RAM 700

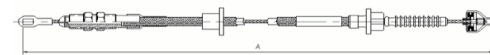

SELECTOR CAMBIOS	4394 FIASC	Ram 700 2012 - 2022	1.0 L 1.3 L 1.4 L	55260374	SC174	 1060mm
CONTROL CAMBIOS	4393 FIACC	Ram 700 2012 - 2022	1.0 L 1.3 L 1.4 L	55270522	CC146	 977mm

MITSUBISHI - TREDIA

EMBRAGUE	1030 MITE	Tredia 1982	L4 Cil. 1.8 L	MB012169	EM51	 1365mm
----------	---------------------	----------------	------------------	----------	------	--

NISSAN

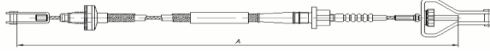
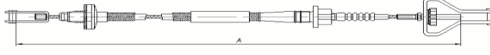
NISSAN - ALTIMA

SELECTOR DE CAMBIOS	4128 NISSC	Altima 2004-2006	3.5L	349358Y000	SC115	 1510mm
EMBRAGUE	1848 NISEM	Altima 1996-1998	L4 Cil. 2.4 L	307709B400	EM41	 737mm
	1849 NISEM	Altima 1994 - 1996	L4 Cil. 2.4 L	307702M105	EM41	 709mm
ACELERADOR	3457 NISAC	Altima GLE, GXE, SE, XE 1993-1995	L4 Cil. 2.4 L	182011E500	AC250	 2026mm

NISSAN - APRIO







EMBRAGUE	2547 RENEM	Aprío 2007-2011	L4 Cil. 1.6 L	6001546867 8200215961	EM111	 1135mm
FRENO DE MANO	2501 RENFP	Aprío 2004...	L4 Cil. 1.6 L	6001547169 8200380738	FP198Trasero Derecho/izquierdo	 1665mm

Automóvil - Suv - Van - Pickup - Camiones Pesados - Ligeros

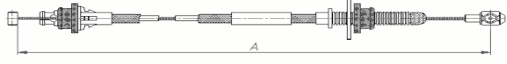
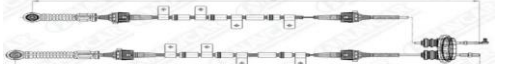
IMPORTANTE. Evite devoluciones o reclamos. Identifique previamente: marca, modelo y año del vehículo. En caso de duda, **CONSULTE** a su asesor.

NUESTRA MISIÓN... Ser su aliado en el desarrollo y crecimiento de su negocio

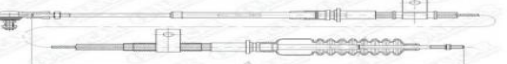
Competimos directamente con los ORIGINALES

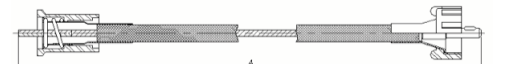
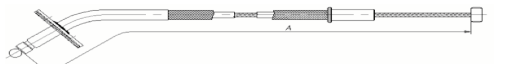
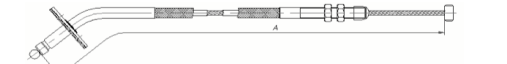
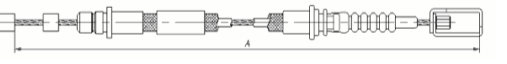
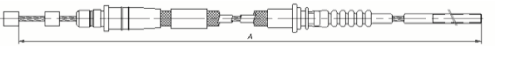
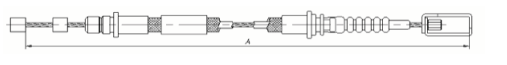





LINEA	CODIGO	MODELO	MOTOR	O.E.M	ARMADO	IMAGEN -- LONGITUD
ACELERADOR	2639 RENAC	Aprio 2004...	L4 Cil. 1.6 L	6001546868	AC219	 953mm
NISSAN - CABSTAR						
KIT CONTROL Y SELECTOR CAMBIO	3471 NISCC	Cabstar T/Estándar	Diesel ZD30 3.0L 6 vel	34413LA20D	CC44	 A=3275mm/B=3320mm
KIT CONTROL Y SELECTOR CAMBIOS	3472 NISCC	Cabstar NT500 T/Estándar	Diesel ZD30 3.0L 6 vel	34413-LA20E	CC44	 A=3269mm/B=3318mm
CONTROL CAMBIOS (Transversal)	2047 NISCC	Cabstar MT-3500 2005... T/Estándar	0	344139X514L	CC16	 2923mm
SELECTOR CAMBIOS (Selector)	2048 NISSN	Cabstar MT-3500 2005... T/Standar	0	344139X514C	SN4	 2923mm
CONTROL CAMBIOS (Transversal)	1732 NISCC	Cabstar MT-3500 2002 - 2004	0	344139X201C (CORTA)	CC3	 2783mm
SELECTOR CAMBIOS (Selector)	1733 NISSN	Cabstar MT-3500 2002 - 2004	0	344139X201L (LARGO)	SC2	 3135mm
NISSAN - DATSUN 1500						
VELOCIMETRO	1854 NISVZ	Datsun 1979-1984	L4 Cil. 1.8 L 2.0 L 2.4 L 2.5 L	2505003W00	VZ40	 1415mm
ACELERADOR	380 NISA	Datsun (1500 Japanese) 1977 - 1979	L4 Cil. 2.4 L 2.5 L	18200B9701	AC59	 608mm
	451 NISA	Datsun (1500 Mexicana) 1972 - 1975	L4 Cil. 2.4 L 2.5 L	18200B5201	AC60	 453mm
NISSAN - DATSUN 620 - 720						
FRENO DE MANO	1748 NISFP	Datsun G720 King Cab ...1994	L4 Cil. 1.8 L 2.0 L 2.4 L 2.5 L	3653104W10	FP84 Trasero Izquierdo	 1493mm
	1105 NISF	Datsun G720 King Cab ...1994	L4 Cil. 1.8 L 2.0 L 2.4 L 2.5 L	3653004W10	FP83 Trasero Derecho	 1682mm
	1757 NISFP	Datsun G720 Cabina simple ...1994	L4 Cil. 1.8 L 2.0 L 2.4 L 2.5 L	3653104W00	FP84 Trasero Izquierdo	 1263mm

Automóvil - Suv - Van - Pickup - Camiones Pesados - Ligeros

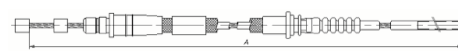

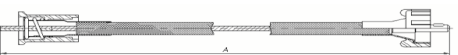

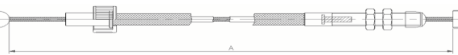
IMPORTANTE. Evite devoluciones o reclamos. Identifique previamente: marca, modelo y año del vehículo. En caso de duda, **CONSULTE** a su asesor.

NUESTRA MISIÓN... Ser su aliado en el desarrollo y crecimiento de su negocio

Competimos directamente con los ORIGINALES

LINEA	CODIGO	MODELO	MOTOR	O.E.M	ARMADO	IMAGEN -- LONGITUD
VELOCIMETRO	1104 NISF	Datsun G720 Cabina simple ...1994	L4 Cil. 1.8 L 2.0 L 2.4 L 2.5 L	3653004W00	FP83 Trasero Derecho	 1453mm
	1279 NISVZ	Datsun 720 (Mexicana)	L4 Cil. 1.8 L 2.0 L 2.4 L 2.5 L	2505034W00 2505034W03	VZ12	 1799mm
ACELERADOR	852 NISVZ	Datsun 720 1981 - 1988	L4 Cil. 1.8 L 2.0 L 2.4 L 2.5 L	2505033W00	VZ40	 1853mm
	1026 NISA	Datsun 720-G720 1983-1985	0	1820044W01	AC63	 905mm
	1011 NISA	Datsun 620, G20 1972 - 1974	L4 Cil. 2.4 L 2.5 L	18200B5500	AC61	 500mm
	635 NISA	Datsun 620, G20 1977 - 1979	L4 Cil. 2.4 L 2.5 L	18200B5200	AC61	 445mm
	1290 NISA	Datsun 720 1980 - 1983	L4 Cil. 2.4 L 2.5 L	1820044W00 1820144W00	AC63	 897mm
	1670 NISA	Datsun 720 1991 - 1994	L4 Cil. 2.4 L 2.5 L	1820123W00	AC63	 493mm

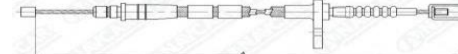
NISSAN - DATSUN D21

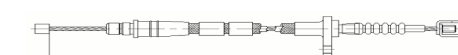







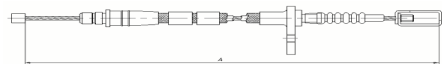

FRENO DE MANO	1758 NISFP	Datsun D21 1994 - 2001	L4 Cil. 1.8 L 2.0 L 2.4 L 2.5 L	3653108G00	FP86 Trasero Izquierdo	 2028mm
	1750 NISFP	Datsun D21 1989 - 1994	L4 Cil. 1.8 L 2.0 L 2.4 L 2.5 L	3653008G00	FP85 Trasero Derecho	 1465mm
	1753 NISFP	Datsun GD21 1985...	L4 Cil. 1.8 L 2.0 L 2.4 L 2.5 L	3653108G10	FP86 Trasero Izquierdo	 2322mm
	1313 NISF	Datsun D21 1986-1990	L4 Cil. 1.8 L 2.0 L 2.4 L 2.5 L	3653011G00	FP85 Trasero Derecho	 1749mm
	1068 NISF	Datsun D21 1985	L4 Cil. 1.8 L 2.0 L 2.4 L 2.5 L	3653111G00	FP86 Trasero Izquierdo	 2230mm
	3970 NISFP	D21 4WD 1992-1998	L4 Cil. 2.4 L 2.5 L	36530-8B010	FP85 Trasero Derecho	 1769mm

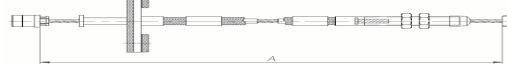
Automóvil - Suv - Van - Pickup - Camiones Pesados - Ligeros

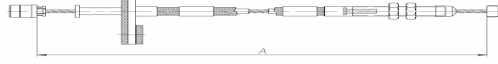
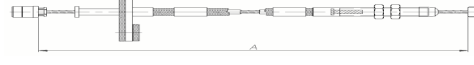
IMPORTANTE. Evite devoluciones o reclamos. Identifique previamente: marca, modelo y año del vehículo. En caso de duda, **CONSULTE** a su asesor.

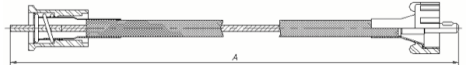
NUESTRA MISIÓN... Ser su aliado en el desarrollo y crecimiento de su negocio

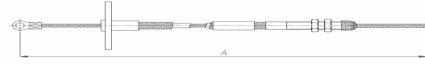
Competimos directamente con los ORIGINALES



LINEA	CODIGO	MODELO	MOTOR	O.E.M	ARMADO	IMAGEN -- LONGITUD
FRENO DE MANO	1751 NISFP	Datsun D21 1989 - 1994	L4 Cil. 1.8 L 2.0 L 2.4 L 2.5 L	3653008G10	FP85 Trasero Derecho	 1767mm
ACELERADOR	1043 NISA	Datsun D21 1985...	L4 Cil. 2.4 L 2.5 L	1820121G00	AC64	 1135mm
	1044 NISA	Datsun D21 1985...	L4 Cil. 2.4 L 2.5 L	1820139G00	AC64	 498mm
	1293 NISA	Datsun D21 1994 - 1996	L4 Cil. 2.4 L 2.5 L	1820101G00	AC64	 1330mm
	2267 NISAC	Datsun D21 fuel injection 1990	L4 Cil. 2.4 L 2.5 L	0	AC182	 1158mm
	2332 NISAC	Datsun D21 VG30E todos 1994	L4 Cil. 2.4 L 2.5 L	1820131G10	AC64	 1610mm
	1775 NISAC	Datsun D21 (Americana) 1985...	L4 Cil. 2.4 L 2.5 L	1820109G02	AC64	 1164mm
NISSAN - DATSUN SAKURA						
ACELERADOR	2251 NISAC	Datsun HardTop 1800 1981-1986	L4 Cil. 2.4 L 2.5 L	18201N7900	AC126	 585mm
NISSAN - DATSUN SEDAN						
VELOCIMETRO	1742 NISVZ	Violet - 10 1979 - 1984 T/Automática	0	25050W5610	VZ40	 2100mm
ACELERADOR	2255 NISAC	Datsun Sedan	L4 Cil. 2.4 L 2.5 L	0	AC66	 545mm
	2250 NISAC	Datsun sedan, Guayin 1979-1987	L4 Cil. 2.4 L 2.5 L	18201W87GO	AC213	 445mm
NISSAN D21						
FRENO DE MANO	4266 NISFP	D21 PICK UP 1986-2007	2.4L	3640208G00	FP500	 1191mm
VELOCIMETRO	1842 NISVZ	D21 PICK UP 1985...	0	505031G01	VZ73	 2091mm
NISSAN D23						

Automóvil - Suv - Van - Pickup - Camiones Pesados - Ligeros







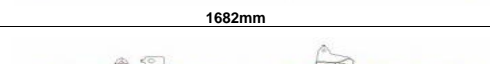

IMPORTANTE. Evite devoluciones o reclamos. Identifique previamente: marca, modelo y año del vehículo. En caso de duda, **CONSULTE** a su asesor.

NUESTRA MISIÓN... Ser su aliado en el desarrollo y crecimiento de su negocio

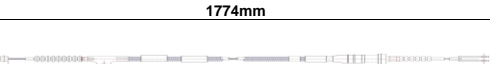
Competimos directamente con los ORIGINALES

LINEA	CODIGO	MODELO	MOTOR	O.E.M	ARMADO	IMAGEN -- LONGITUD
FRENO DE MANO	4175 NISFP	Nissan D23 Cabina Doble 2016...	2.5L	365304KH0B	FP475 Trasero Derecho	 2151mm
FRENO DE MANO	4176 NISFP	Nissan D23 Cabina Doble 2016...	2.5L	365314KH0B	FP476 Trasero Izquierdo	 2416mm
	4226 NISFP	D23 Cabina Sencilla 2016...	2.5L	36531-4KH0A	FP488 Trasero Izquierdo	 1682mm
	4227 NISFP	Nissan D23 Cabina Sencilla 2016...	2.5L	36530-4KH0A	FP489 Trasero Derecho	 1397mm

NISSAN - FRONTIER







SELECTOR CAMBIOS	4357 NISSC	Frontier 2005-2020	2.5L 4.0L	349354X00B 34935ZS02A	SC163	 1353mm
FRENO DE MANO	4105 NISFP	Frontier 4X2 Doble Cabina 1998-2012	2.4L	36530VK00A	FP445 Trasero Derecho	 1774mm
FRENO DE MANO	3760 NISFP	Frontier SV, S, PRO-AX, SL, XE 2005-2014	L4 Cil. 2.5 L V6 Cil. 4.0 L	36530-EB00A	FP378 Trasero Derecho	 1985mm
FRENO DE MANO	4104 NISFP	Frontier 4X2 Doble Cabina 1998-2012	2.4L	364023S110	FP444 Principal	 1615mm
FRENO DE MANO	4106 NISFP	Frontier 4X2 Doble Cabina 1998-2012	2.4L	36531VK00A	FP446 Trasero Izquierdo	 2248mm
FRENO DE MANO	4175 NISFP	Frontier Cabina Doble 2016...	2.5L	365304KH0B	FP475 Trasero Derecho	 2151mm
FRENO DE MANO	4176 NISFP	Frontier Cabina Doble 2016...	2.5L	365314KH0B	FP476 Trasero Izquierdo	 2416mm
FRENO DE MANO	4226 NISFP	Frontier Cabina Sencilla 2016...	2.5L	36531-4KH0A	FP488 Trasero Izquierdo	 1682mm
FRENO DE MANO	4227 NISFP	Frontier Cabina Sencilla 2016...	2.5L	36530-4KH0A	FP489 Trasero Derecho	 1397mm

Automóvil - Suv - Van - Pickup - Camiones Pesados - Ligeros

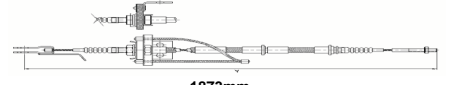
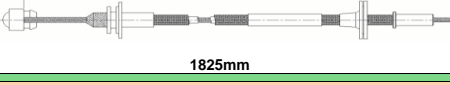
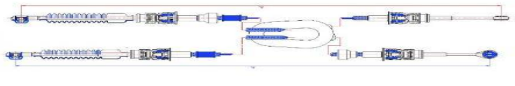
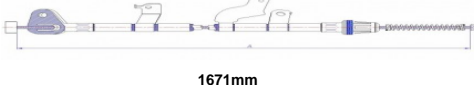
IMPORTANTE. Evite devoluciones o reclamos. Identifique previamente: marca, modelo y año del vehículo. En caso de duda, **CONSULTE** a su asesor.

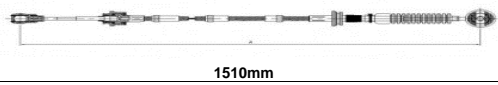
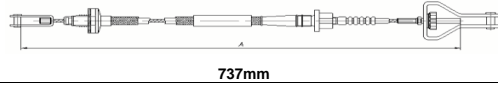
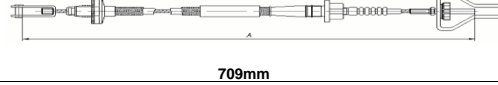
NUESTRA MISIÓN... Ser su aliado en el desarrollo y crecimiento de su negocio

Competimos directamente con los ORIGINALES

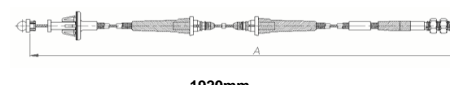





LINEA	CODIGO	MODELO	MOTOR	O.E.M	ARMADO	IMAGEN -- LONGITUD
ACELERADOR	4107 NISAC	Frontier 4X2 Doble Cabina 1998-2012	2.4L	18201VJ500	AC165	 970mm
NISSAN - ICHI VAN						
FRENO DE MANO	1119 NISF	Ichi-van corta 1988-1994	0	3640204C01	FP91	 1873mm
ACELERADOR	2253 NISAC	Ichi-Van Carburator Bocar 1987-1991	L4 Cil. 1.8 L 2.4 L	18201CO7RO	AC72	 1825mm
NISSAN - MARCH						
KIT CONTROL Y SELECTOR CAMBIOS	3927 NISCC	March HR16DE 2011 - 2017 T/Estandar	L4 Cil. 1.6 L	344133AM0A	CC80	 A=1043mm/B=989mm
FRENO DE MANO	4258 NISFP	March 2012....	1.6L	365301HK0A	FP502 Trasero Derecho	 1671mm
FRENO DE MANO	4259 NISFP	March 2012....	1.6L	365311HK0A	FP502 Trasero Izquierdo	 1645mm
NISSAN - MAXIMA						
SELECTOR CAMBIOS	4128 NISCC	Maxima 2004-2005	3.6L	349358Y000	SC115	 1510mm
EMBRAGUE	1848 NISEM	Maxima 1996-1998	L4 Cil. 2.4 L	307709B400	EM41	 737mm
	1849 NISEM	Maxima 1994 - 1996	L4 Cil. 2.4 L	307702M105	EM41	 709mm
FRENO DE MANO	3671 NISFP	Maxima GLE, GXE, SE 2000-2002	V6 Cil. 2.0 L 3.0 L 3.5 L	36530-2Y000	FP353 Trasero Derecho	 1731mm
	3670 NISFP	Maxima SE, GXE, GLE 1995-1999	V6 Cil. 3.0 L	36531-1L000 36531-1L005 36531-31U00	FP352 Trasero Izquierdo	 1684mm
ACELERADOR	2335 NISAC	Maxima 1995	0	1820144U00	AC165	 922mm
	2349 NISAC	Maxima todos 1988	V6 Cil. 3.0 L	1820117E00	AC189	 1920mm
NISSAN - NP300						

Automóvil - Suv - Van - Pickup - Camiones Pesados - Ligeros

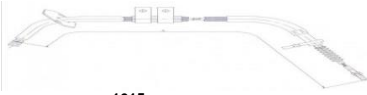
IMPORTANTE. Evite devoluciones o reclamos. Identifique previamente: marca, modelo y año del vehículo. En caso de duda, **CONSULTE** a su asesor.

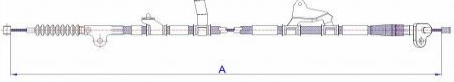
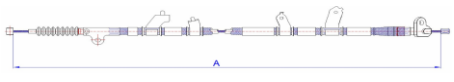
NUESTRA MISIÓN... Ser su aliado en el desarrollo y crecimiento de su negocio



Competimos directamente con los ORIGINALES

LINEA	CODIGO	MODELO	MOTOR	O.E.M	ARMADO	IMAGEN -- LONGITUD
FRENO DE MANO	4104 NISFP	Np300 4X2 Doble Cabina 1998-2012	2.4L	364023S110	FP444 Principal	 1615mm
FRENO DE MANO	4105 NISFP	Np300 4X2 Doble Cabina 1998-2012	2.4L	36530VK00A	FP445 Trasero Derecho	 1774mm
FRENO DE MANO	4106 NISFP	Np300 4X2 Doble Cabina 1998-2012	2.4L	36531VK00A	FP446 Trasero Izquierdo	 2248mm
FRENO DE MANO	4175 NISFP	Np300 Cabina doble 2016...	2.5L	365304KH0B	FP475 Trasero Derecho	 2151mm
FRENO DE MANO	4176 NISFP	Np300 Cabina doble 2016...	2.5L	365314KH0B	FP476 Trasero Izquierdo	 2416mm
FRENO DE MANO	4226 NISFP	Np300 Cabina Sencilla 2016...	2.5L	36531-4KH0A	FP488 Trasero Izquierdo	 1682mm
FRENO DE MANO	4227 NISFP	Np300 Cabina Sencilla 2016...	2.5L	36530-4KH0A	FP489 Trasero Derecho	 1397mm
ACELERADOR	4107 NISAC	Np300 4X2 Doble Cabina 1998-2012	2.4L	18201VJ500	AC165	 970mm

NISSAN - PLATINA

SELECTOR CAMBIOS	4382 NISSC	Platina 2010-2012	1.6L	8200433263	SC173	 1033mm
------------------	----------------------	----------------------	------	------------	-------	--

NISSAN - PATHFINDER

ACELERADOR	3485 NISAC	Pathfinder LE, SE, XE 1996-1999	V6 Cil. 3.3 L	182010W000	AC250 Ref tubo Int Nylon	 1992mm
ACELERADOR	2332 NISAC	Pathfinder VG30E todos 1994	L4 Cil. 2.4 L 2.5 L	1820131G10	AC64	 1610mm

NISSAN - PICKUP D21 TRUCK







	2257 NISAC	Pickup Carburador Hitachi Nacional y Maq. 2000	L4 Cil. 2.4 L 2.5 L	1820192W05	AC63	 1050mm
--	----------------------	--	---------------------------	------------	------	--

Automóvil - Suv - Van - Pickup - Camiones Pesados - Ligeros

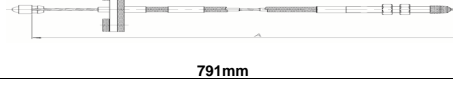

IMPORTANTE. Evite devoluciones o reclamos. Identifique previamente: marca, modelo y año del vehículo. En caso de duda, **CONSULTE** a su asesor.

NUESTRA MISIÓN... Ser su aliado en el desarrollo y crecimiento de su negocio

Competimos directamente con los ORIGINALES

LINEA	CODIGO	MODELO	MOTOR	O.E.M	ARMADO	IMAGEN -- LONGITUD
ACELERADOR	2260 NISAC	Pickup Z24, Maq, 2000, 2200	L4 Cil. 2.4 L 2.5 L	0	AC63	 901mm
	2256 NISAC	Camioneta 1991-1993	L4 Cil. 2.4 L 2.5 L	1820192W05	AC62	 1165mm
ACELERADOR	2269 NISAC	Camioneta fuel injection	L4 Cil. 2.4 L 2.5 L	0	AC182	 1306mm
	2259 NISAC	Camioneta fuel injection 1994-2000	L4 Cil. 2.4 L 2.5 L	1820186G00	AC182	 791mm
	2249 NISAC	Camioneta 1980-1987	L4 Cil. 2.4 L 2.5 L	18200B80RI	AC63	 490mm
	2248 NISAC	Camioneta 1980-1987	L4 Cil. 2.4 L 2.5 L	1820033WRO	AC63	 500mm
	2247 NISAC	Camioneta Carburator Bocar 1980-1986	L4 Cil. 2.4 L 2.5 L	182003WRO	AC62	 715mm
	2252 NISAC	Camioneta D21 Carburator Solex 1988-1993	L4 Cil. 2.4 L 2.5 L	18200P05R1	AC62	 620mm

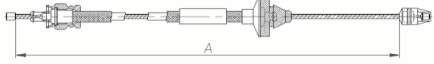
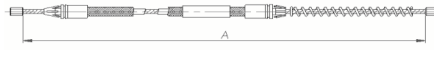
NISSAN - PLATINA

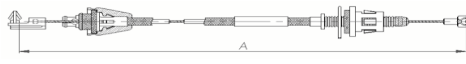
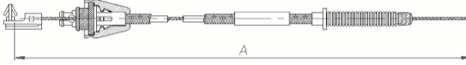
EMBRAGUE	2138 RENEM	Platina todos	L4 Cil. 1.6 L	8200278120	EM89	 960mm
FRENO DE MANO	2017 RENFP	Platina 2000...	L4 Cil. 1.6 L	8200278126 36531 00 QAA	FP186 Trasero Izquierdo	 1337mm
	2018 RENFP	Platina 2000...	L4 Cil. 1.6 L	8200278128 36530 00 QAA	FP186 Trasero Derecho	 1417mm
ACELERADOR	2136 RENAC	Platina 1999 - 2002	L4 Cil. 1.6 L	8200278139	AC154	 898mm
	2135 RENAC	Platina 2003...	L4 Cil. 1.6 L	8200278138A	AC153	 1330mm

NISSAN - ROGUE

SELECTOR CAMBIOS	4144 NISSC	Rogue 2008-2015 (Automática)	2.5L	34935JM000	SC115	 1295mm
------------------	----------------------	------------------------------------	------	------------	-------	--







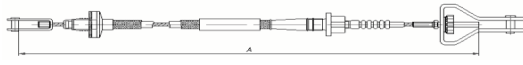
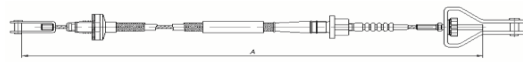
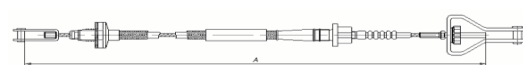
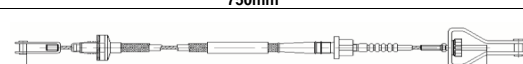
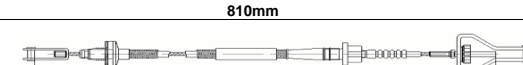

Encino 1287 col. del Fresno Guadalajara Jal.

Automóvil - Suv - Van - Pickup - Camiones Pesados - Ligeros

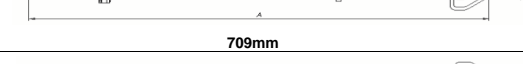
IMPORTANTE. Evite devoluciones o reclamos. Identifique previamente: marca, modelo y año del vehículo. En caso de duda, **CONSULTE** a su asesor.

NUESTRA MISIÓN... Ser su aliado en el desarrollo y crecimiento de su negocio

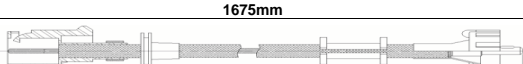
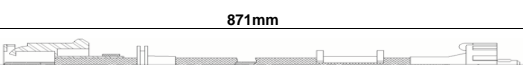
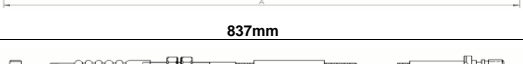
Competimos directamente con los ORIGINALES





LINEA	CODIGO	MODELO	MOTOR	O.E.M	ARMADO	IMAGEN -- LONGITUD
NISSAN - SENTRA						
EMBRAGUE	364 NISE	Sentra 1981 - 1988	L4 Cil. 1.4 L 1.6 L 1.8 L 2.0 L	3067004A00	EM171	 700mm
	2473 NISEM	Sentra (Gas) 1989	L4 Cil. 1.4 L 1.6 L 1.8 L 2.0 L	3067005B00 3077060AR0	EM41	 800mm
	1028 NISE	Sentra 1992 - 1994	L4 Cil. 1.4 L 1.6 L 1.8 L 2.0 L	3067013E01	EM171	 750mm
	953 NISE	Sentra B12 1986-1989	L4 Cil. 1.4 L 1.6 L 1.8 L 2.0 L	3077060A01	EM171	 810mm
	1294 NISE	Sentra B13 1992 - 1994	L4 Cil. 1.4 L 1.6 L 1.8 L 2.0 L	3077074Y10	EM41	 755mm
	1295 NISE	Sentra 1990 - 1994	L4 Cil. 1.4 L 1.6 L 1.8 L 2.0 L	3077064Y10	EM41	 726mm
	1849 NISEM	Sentra B14 1994 - 1996	L4 Cil. 2.4 L	307702M105	EM41	 709mm
	944 NISE	Sentra B13 1990 - 1998	L4 Cil. 1.4 L 1.6 L 1.8 L 2.0 L	3077062Y10 3077062Y01 30770-62Y1A	EM171	 755mm
	1850 NISEM	Sentra B12-B14 1996 - 1998	L4 Cil. 1.4 L 1.6 L 1.8 L 2.0 L	307701M200	EM41	 680mm
	3674 NISFP	Sentra GXE, XE, SE, GLE; 200SX SE-R, SE 1995 - 1999	L4 Cil. 1.6 L 2.0 L	36530-4B065	FP352 Trasero Derecho	 1675mm
VELOCIMETRO	819 NISVZ	Sentra 1982-1993	L4 Cil. 1.4 L 1.6 L 1.8 L 2.0 L	2505002A05	VZ12	 871mm
	765 NISVZ	Sentra B13 1993-2000	L4 Cil. 1.4 L 1.6 L 1.8 L 2.0 L	2505065Y02	VZ12	 837mm
SOBREMARCHA	1719 NISB	Sentra 1988 - 1993	0	3105101X18 3105101X22	SB26	 1130mm
	2078 NISB	Sentra B12 1988 - 1993	0	3105101X20	SB26	 1068mm
	3321 NISAC	Sentra E16 1982...	L4 Cil. 1.6 L	1820136A00	AC243	 946mm

Automóvil - Suv - Van - Pickup - Camiones Pesados - Ligeros

IMPORTANTE. Evite devoluciones o reclamos. Identifique previamente: marca, modelo y año del vehículo. En caso de duda, **CONSULTE** a su asesor.

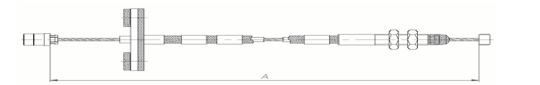
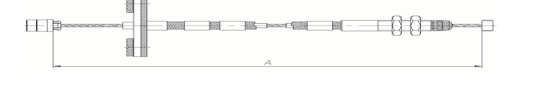
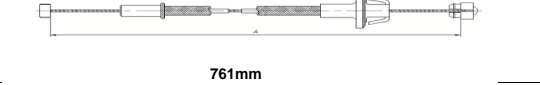
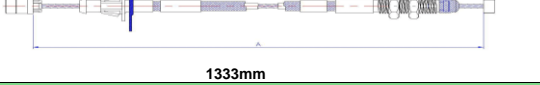
NUESTRA MISIÓN... Ser su aliado en el desarrollo y crecimiento de su negocio

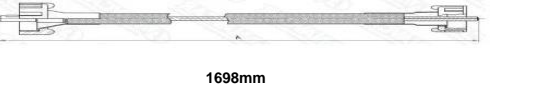
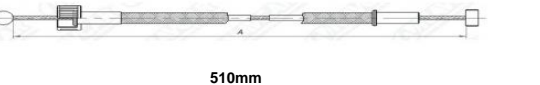
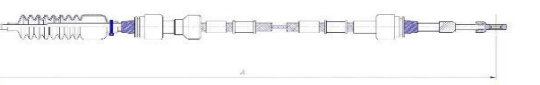
Competimos directamente con los ORIGINALES

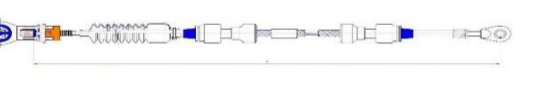
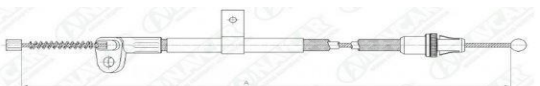
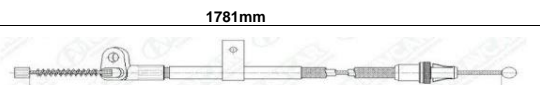





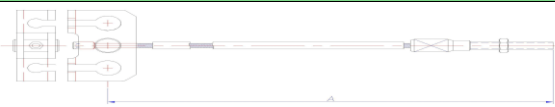
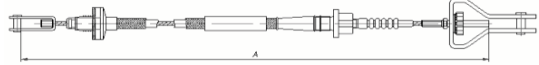
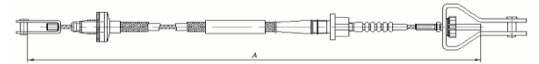
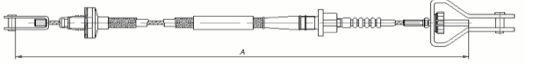

LINEA	CODIGO	MODELO	MOTOR	O.E.M	ARMADO	IMAGEN -- LONGITUD
ACELERADOR	3641 NISAC	Sentra B14 1990-1995	1.4L 1.6L	18201-59J02	AC250	 1272mm
	1045 NISA	Sentra B12 1985	L4 Cil. 1.6 L	1820160A00	AC165	 1003mm
	1717 NISA	Sentra B12 1985	L4 Cil. 1.6 L	1820173A00	AC165	 1010mm
	468 NISA	Sentra B11, B14 1982 - 1988	L4 Cil. 1.6 L	1820104A10	AC67	 761mm
	3842 NISAC	Sentra Sedan 1997-2011	L4 Cil. 1.3 L	18201-F4204	AC270	 1333mm
NISSAN - 240 SX						
ACELERADOR	2339 NISAC	Nissan 240 sx 1991-1994	0	1820154F00	AC165	 1260mm
NISSAN - SUNNY						
VELOCIMETRO	1276 NISVZ	Sunny B110-120 1970-...	L4 Cil. 1.2 L 1.4 L	25050H1602	VZ39	 1698mm
ACELERADOR	1287 NISA	Sunny B210 1973-1976	0	18200H6100	AC68	 510mm
NISSAN - TIIDA						
SELECTOR CAMBIOS	3819 NISSC	Tiida Sedan 2007-2012 T/Automática	L4 Cil. 1.8 L	34935EM30A	SC80	 1732mm
CONTROL CAMBIOS (Transversal)	3988 NISSC	Tiida 2007-2017 T/Estándar	L4 Cil. 1.8 L	34445-EM32A	CC94	 1099mm
SELECTOR CAMBIOS (Selector)	3820 NISSC	Tiida Sedan 2007-2012 T/Estándar	L4 Cil. 1.8 L	34415EM30A	CC60	 1108mm
FRENO DE MANO	3828 NISFP	Tiida 2007-2012	1.8L	36530-EL000	FP385 Trasero Derecho	 1781mm
	3829 NISFP	Tiida 2007-2012	1.8L	36531-EL000	FP386 Trasero Izquierdo	 1692mm

Automóvil - Suv - Van - Pickup - Camiones Pesados - Ligeros

IMPORTANTE. Evite devoluciones o reclamos. Identifique previamente: marca, modelo y año del vehículo. En caso de duda, **CONSULTE** a su asesor.

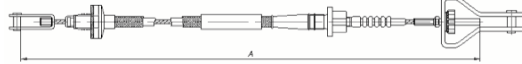
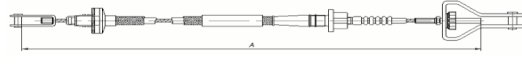
NUESTRA MISIÓN... Ser su aliado en el desarrollo y crecimiento de su negocio

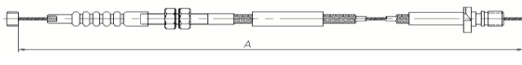
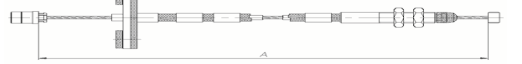
Competimos directamente con los ORIGINALES

LINEA	CODIGO	MODELO	MOTOR	O.E.M	ARMADO	IMAGEN -- LONGITUD
	3825 NISFP	Tiida 2007-2012	L4 Cil. 1.8 L 1.6 L	36402-EM10A	FP383 Principal	 208mm
NISSAN - TSURU						
EMBRAGUE	1295 NISE	Tsuru 1990 - 1994	L4 Cil. 1.4 L 1.6 L 1.8 L 2.0 L	3077064Y10	EM41	 726mm
	1294 NISE	Tsuru 1992 - 1994	L4 Cil. 1.4 L 1.6 L 1.8 L 2.0 L	3077074Y10	EM41	 755mm
NISSAN - TSURU I						
EMBRAGUE	364 NISE	Tsuru I 1984 - 1987	L4 Cil. 1.4 L 1.6 L 1.8 L 2.0 L	3067004A00	EM171	 700mm
FRENO DE MANO	1485 NISF	Tsuru I 1982-1987	L4 Cil. 1.6 L	3653001A01	FP87 Trasero Derecho	 888mm
FRENO DE MANO	1306 NISF	Tsuru I 1982-1987	L4 Cil. 1.6 L	3653101A01	FP88 Trasero Izquierdo	 1090mm
SOBREMARCHA	1719 NISB	Tsuru I 1988 - 1991	0	3105101X18 3105101X22	SB26	 1130mm
NISSAN - TSURU II						
EMBRAGUE	1851 NISEM	Tsuru II 1988 - 1992	L4 Cil. 1.4 L 1.6 L 1.8 L 2.0 L	3077060AR0	EM171	 797mm
	1028 NISE	Tsuru II 1992 - 1994	L4 Cil. 1.4 L 1.6 L 1.8 L 2.0 L	3067013E01	EM171	 750mm
VELOCIMETRO	1839 NISVZ	Tsuru II 1987-1992	L4 Cil. 1.4 L 1.6 L 1.8 L 2.0 L	2505065Y02	VZ12	 852mm
SOBREMARCHA	2300 NISB	Tsuru II 1984-1987	0	3105101X84	SB26	 1240mm
ACELERADOR	1045 NISA	Tsuru II 1988-1991	L4 Cil. 1.6 L	1820160A00	AC165	 1003mm
	2258 NISAC	Tsuru II 1988-1991 T/Standar	L4 Cil. 1.6 L	1820164A20	AC181	 810mm
	1717 NISA	Tsuru II Carburador Hitachi	L4 Cil. 1.6 L	1820173A00	AC165	 1010mm







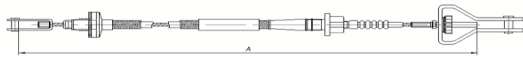
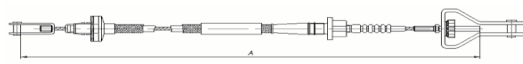
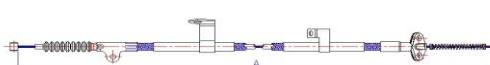

Enchro 1287 col. del Frenso Guadalajara Jal.

Automóvil - Suv - Van - Pickup - Camiones Pesados - Ligeros

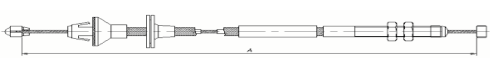
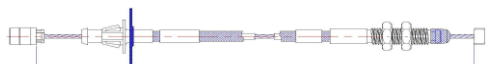
IMPORTANTE. Evite devoluciones o reclamos. Identifique previamente: marca, modelo y año del vehículo. En caso de duda, **CONSULTE** a su asesor.

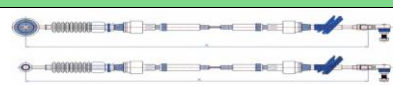
NUESTRA MISIÓN... Ser su aliado en el desarrollo y crecimiento de su negocio

Competimos directamente con los ORIGINALES



LINEA	CODIGO	MODELO	MOTOR	O.E.M	ARMADO	IMAGEN -- LONGITUD
NISSAN - TSURU III						
EMBRAGUE	944 NISE	Tsuru III 1993-2017	L4 Cil. 1.4 L 1.6 L 1.8 L 2.0 L	30770F4203	EM171	 755mm
	1853 NISEM	Tsuru III GTS 1995-2006	L4 Cil. 1.4 L 1.6 L 1.8 L 2.0 L	3077064Y01	EM41	 724mm
FRENO DE MANO	3459 NISFP	Tsuru III LE 1993-2011	L4 Cil. 1.4 L 1.6 L 1.8 L 2.0 L	3653150Y10	FP339 Trasero Izquierdo	 1408mm
	3460 NISFP	Tsuru III LE 1993-2011	L4 Cil. 1.4 L 1.6 L 1.8 L 2.0 L	3653050Y10	FP340 Trasero Derecho	 1408mm
VELOCIMETRO	765 NISVZ	Tsuru III 1991-2011	L4 Cil. 1.4 L 1.6 L 1.8 L 2.0 L	2505065Y02	VZ12	 837mm
ACELERADOR	2268 NISAC	Tsuru III 1995-2010	L4 Cil. 1.6 L	18201F4204	AC70 Sin Placa	 1335mm
	3842 NISAC	Tsuru III 1993-2015	L4 Cil. 1.3 L	18201-F4204	AC270	 1333mm
	3457 NISAC	Tsuru III 1995-1997	1.6L	182011E500	AC270	 2026mm
NISSAN - URVAN						
KIT CONTROL Y SELECTOR CAMBIOS	3952 NISCC	Urvan ZD30 2002 - 2015 T/Estándar	0	34413-VW711	CC74	 A=2144mm/B=2279mm
KIT CONTROL Y SELECTOR CAMBIOS	3987 NISCC	Urvan 2007-2015 T/Estándar	L4 Cil. 2.5 L	34413-VZ10D	CC82	 A=2117mm/B=2322mm
	3951 NISCC	Urvan KA24DE 2005 - 2009 T/Estándar	L4 Cil. 2.4 L	34413-VW701	CC74	 A=2125mm/B=2247mm
CONTROL CAMBIOS (Transversal)	3955 NISCC	Urvan 2.5L T/Estándar	0	0	CC76	 2090mm
SELECTOR CAMBIOS (Selector)	4155 NISCC	Urvan 2007 T/Estándar	0	0	SC120	 2103mm

Automóvil - Suv - Van - Pickup - Camiones Pesados - Ligeros

IMPORTANTE. Evite devoluciones o reclamos. Identifique previamente: marca, modelo y año del vehículo. En caso de duda, **CONSULTE** a su asesor.

NUESTRA MISIÓN... Ser su aliado en el desarrollo y crecimiento de su negocio

Competimos directamente con los ORIGINALES

LINEA	CODIGO	MODELO	MOTOR	O.E.M	ARMADO	IMAGEN -- LONGITUD
ACELERADOR	128 NISA	Urvan E24 1986 - 1996	L4 Cil. 2.5 L	1820107N00	AC232	 2340mm
	1502 NISA	Urvan Diesel Motor TD27 1997...	L4 Cil. 2.5 L	1820131N00	AC232	 2434mm

NISSAN - VERSA

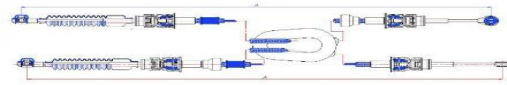
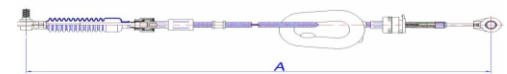
KIT CONTROL Y SELECTOR CAMBIOS	3927 NISCC	Versa 5 Vel. HR16DE 2011 - 2017 T/Estandar	L4 Cil. 1.6 L	344133AM0A	CC80	 A=1043mm/B=989mm
SELECTOR CAMBIOS	4375 NISCC	Versa 2012- 2019 T/Automatica	1.6 L	349351HK1A 349359KH0A	SC167	 1208mm

OLDSMOBILE



OLDSMOBILE - ACHIERA

FRENO DE MANO	2871 GMCFP	Achiera 1997-2002	L4 Cil. 2.4 L	22651234	FP220Trasero Derecho/Izquierdo	 634mm
ACELERADOR	3560 GMCAC	Achiera 1997-2004	L4 Cil. 2.5 L	22619741	AC258	 1427mm

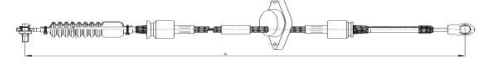
OLDSMOBILE - AURORA

SELECTOR CAMBIOS	3645 GMCSC	Aurora 2001 - 2005	0	15774348	SC68	 2108mm
	3644 GMCSC	Aurora 2000 - 2005	V6 Cil. 3.5 L	15774347	SC68	 2240mm
FRENO DE MANO	2807 GMCFP	Aurora 2001 - 2005	V6 Cil. 3.5 L V8 Cil. 4.0 L	25712419	FP239Trasero Derecho/Izquierdo	 749mm

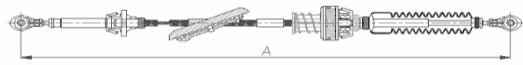
OLDSMOBILE - BRAVADA

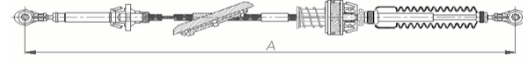

SELECTOR CAMBIOS	3402 GMCSC	Bravada Traccion 4x4 1995-1997 T/Automática	V6 Cil. 4.3 L	15721261	SC27 Palanca al volante	 2576mm
SELECTOR CAMBIOS	3807 GMCSC	Bravada 1998-2005 T/Automática	V6 Cil. 4.3L	15189203	SC27	 2861mm
	3866 GMCSC	Bravada 1998-2005 T/Automática	L4 Cil. 2.2 L V6 Cil. 4.3 L	15189199	SC27	 2042mm

Automóvil - Suv - Van - Pickup - Camiones Pesados - Ligeros

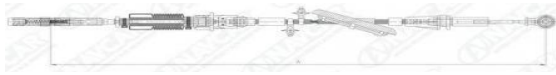

¡IMPORTANTE. Evite devoluciones o reclamos. Identifique previamente: marca, modelo y año del vehículo. En caso de duda, **CONSULTE** a su asesor.

NUESTRA MISIÓN... Ser su aliado en el desarrollo y crecimiento de su negocio

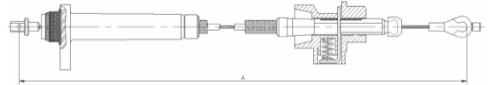



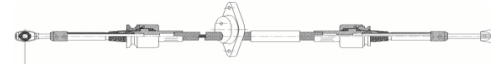

Competimos directamente con los ORIGINALES

LINEA	CODIGO	MODELO	MOTOR	O.E.M	ARMADO	IMAGEN -- LONGITUD
	3761 GMCS	Bravada 2002 - 2009	L4 Cil. 4.2 L 5.3 L 6.0 L	15785087 10357836 15079394 15101412	SC79	 1886mm
FRENO DE MANO	2621 GMCFP	Bravada 1998 - 2001	V6 Cil. 4.3 L	15724598	FP240 Principal	 923mm
SOBREMARCHA	2040 GMCSB	Bravada Traccion 2R, Traccion 4x4 1991	0	10111682	SB2	 1028mm

OLDSMOBILE - CALAIS

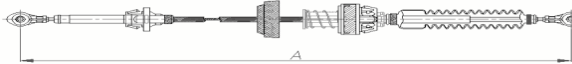
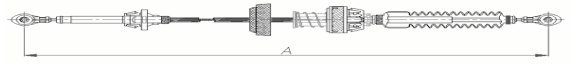
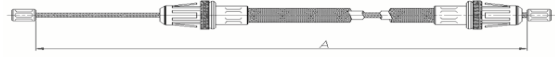
SELECTOR CAMBIOS	3423 GMCS	Calais 1986-1987 T/Estándar	L4 Cil. 2.3 L	2253553 2253554 2253555 10066450 14093374	SC68	 1278mm
	3058 GMCS	Calais International 1988-1991 T/Estándar	L4 Cil. 2.3 L	10079796 22539956	SC50	 1280mm
	1768 GMCS	Calais w/THM125 AT. 1985 - 1991 T/Automática	L4 Cil. 2.5 L	10022405	SC15	 1265mm

OLDSMOBILE - CUTLASS

SELECTOR CAMBIOS (Selector)	3058 GMCS	Cutlass Calaris 1988 - 1991 T Estandar	L4 Cil 2.3L	10079796 10111636 10142095 10174427	SC50	 1280mm
SELECTOR CAMBIOS (Selector)	3057 GMCS	Cutlass 1988-1991 T/Estándar	L4 Cil. 2.3 L	100779847 / 22539962	SC49	 1262mm
SELECTOR CAMBIOS	3416 GMCS	Cutlass 1986-1996 T/Automática	V6 Cil. 3.8 L	12552510	SC29	 1504mm
	2529 GMCS	Cutlass THM440-T4 THM125 1986 - 1992 T/Automática	L4 Cil. 2.5 L V6 Cil. 2.8 L 3.3 L	10038603	SC29	 1508mm
FRENO DE MANO	2805 GMCFP	Cutlass Supreme, SL 1996 - 1997	V6 Cil. 3.4 L	10287296	FP240 Trasero Izquierdo	 2115mm
SOBREMARCHA	2033 GMCSB	Cutlass 1990 - 1993	0	10163881	SB2	 1280mm
SOBREMARCHA	2289 GMCSB	Cutlass Ciera 1982-1985	V6 Cil. 4.3 L	25510971	SB2	 776mm
SOBREMARCHA	2290 GMCSB	Cutlass 1980..	4.3	25503382	SB19	 960mm

Automóvil - Suv - Van - Pickup - Camiones Pesados - Ligeros



IMPORTANTE. Evite devoluciones o reclamos. Identifique previamente: marca, modelo y año del vehículo. En caso de duda, **CONSULTE** a su asesor.

NUESTRA MISIÓN... Ser su aliado en el desarrollo y crecimiento de su negocio

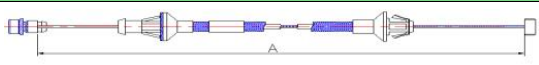
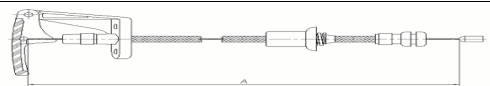
Competimos directamente con los ORIGINALES

LINEA	CODIGO	MODELO	MOTOR	O.E.M	ARMADO	IMAGEN -- LONGITUD
ACELERADOR	3560 GMCAC	Cutlass 1997-2004	L4 Cil. 2.5 L	22619741	AC258	 1427mm
APERTURA COFRE	1444 CHEC	Cutlass	V6 Cil. 1.7 L V8 Cil. 4.7 L	10270780	CP16	 2020mm

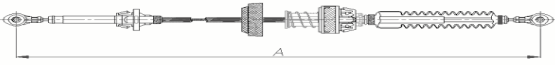
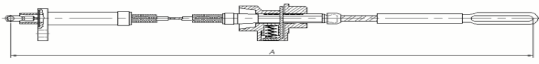

OLDSMOBILE - DELTA

SELECTOR CAMBIOS	3097 GMCSC	Delta 88 1986-1993 T/Automática	V6 Cil. 3.8 L	25527523	SC29	 1352mm
SOBREMARCHA	1820 GMCSCB	Delta 88 THM350 1979	V8 Cil. 4.3 L	1262622	SB3	 950mm
SOBREMARCHA	2290 GMCSCB	Delta 88 THM350 1988	V8 Cil. 5.0 L	25503382	SB19	 960mm

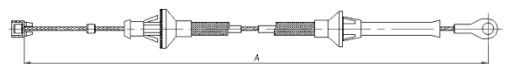
OLDSMOBILE - FIRENZA

SELECTOR CAMBIOS (Selector)	3423 GMCSC	Firenza 1986-1987 T/Estándar	L4 Cil. 2.3 L	2253553 2253554 2253555 10066450 14093374	SC68	 1278mm
ACELERADOR	1818 GMCAC	Firenza 1987	V6 Cil. 2.8 L	10079816	AC1	 820mm

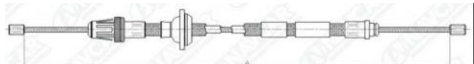
OLDSMOBILE - INTRIGUE

FRENO DE MANO	2806 GMCFCP	Intrigue 1977 - 2001	V6 Cil. 3.5 L 3.8 L	10306507	FP288 Principal	 2990mm
ACELERADOR	3567 GMCAC	Intrigue 1997 - 1999	V6 Cil. 3.8 L	12557988	AC254	 1646mm
	3450 GMCAC	Intrigue 1998 - 2004	V6 Cil. 3.8 L	10332800	AC254	 1586mm

OLDSMOBILE - NINETY-EIGHTH

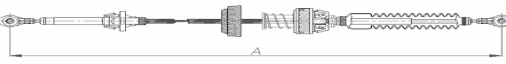
SELECTOR CAMBIOS	3097 GMCSC	Ninety-Eighth 1986-1993 T/Automática	V6 Cil. 3.8 L	25527523	SC29	 1352mm
------------------	----------------------	--	------------------	----------	------	--

OLDSMOBILE - OMEGA

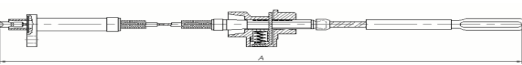
SELECTOR CAMBIOS (Selector)	3776 GMCSC	Omega 1981 T/Automática	0	10017823	SC76	 1273mm
	559 CHSB	Omega, Todos W/THM350 1976-1977	0	1262618	SB3	 1114mm

Encino 1287 col. del Fresno Guadalajara Jal.





Tel. Multilínea (33) 3811 6917 - Servi-Cliente Cel. 33 1992 6768 - Guadalajara, Jalisco
Correo: ventas@flexcontrol.com.mx - www.flexcontrol.com.mx - www.cablesnavcar.com

Automóvil - Suv - Van - Pickup - Camiones Pesados - Ligeros

IMPORTANTE. Evite devoluciones o reclamos. Identifique previamente: marca, modelo y año del vehículo. En caso de duda, **CONSULTE** a su asesor.

NUESTRA MISIÓN... Ser su aliado en el desarrollo y crecimiento de su negocio

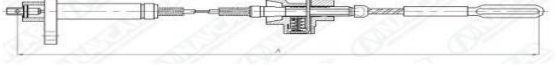
Competimos directamente con los ORIGINALES

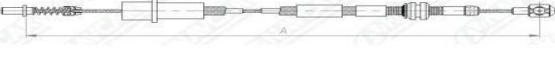
LINEA	CODIGO	MODELO	MOTOR	O.E.M	ARMADO	IMAGEN -- LONGITUD
SOBREMARCHA	1658 GMSB	Omega THM125C 1980 - 1981	0	25513389	SB2	 607mm
	1659 GMSB	Omega THM125C 1982 - 1983	0	25513393	SB2	 1035mm
	1611 GMSB	Omega THM200 1977	0	1253966	SB20	 894mm
	1617 GMSB	Omega THM125C 1984	0	25519347	SB2	 1120mm
ACCELERADOR	3322 GMCAC	Omega 1993-2002	V6 Cil. 2.8 L	90411037 847061	AC7	 835mm

OLDSMOBILE - REGENCY

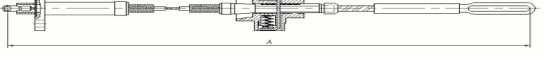
SELECTOR CAMBIOS	2041 GMCSC	Regency todos 1985 - 1998 T/Automática	L4 Cil. 2.5 L	25524872	SC12	 1474mm
SOBREMARCHA	1820 GMCSCB	Regency TH-350 1977 - 1979	V8 Cil. 4.3 L	1262622	SB3	 950mm

PEUGEOT

PEUGEOT - 206



FRENO DE MANO	4100 PEUFP	206 2007-2009	1.4L	4745N5	FP440 Trasero Derecho	 1640mm
	4101 PEUFP	206 2007-2009	1.4L	4745N4	FP441 Trasero Izquierdo	 1640mm

PEUGEOT - PARTNER

EMBRAGUE	4288 PEUEM	Partner 2008	0	9661239180 9648780380	EM175	 900mm
----------	---------------	-----------------	---	--------------------------	-------	---

PLYMOUTH

PLYMOUTH - ACCLAIM

SELECTOR CAMBIOS	2117 CHRSC	Acclaim 1991 - 1995 T/Automática	L4 Cil. 2.5 L	4543042	SC23	 1422mm
	2127 CHRSC	Acclaim 1991 - 1995 T/Automática	L4 Cil. 2.5 L V6 Cil. 3.0 L	4543046 4543047	SC25	 892mm

Encino 1287 col. del Fresno Guadalajara Jal.







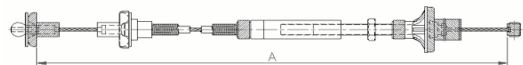

Tel. Multilínea (33) 3811 6917 - Servi-Cliente Cel. 33 1992 6768 - Guadalajara, Jalisco
Correo: ventas@flexcontrol.com.mx - www.flexcontrol.com.mx - www.cablesnavcar.com

Automóvil - Suv - Van - Pickup - Camiones Pesados - Ligeros

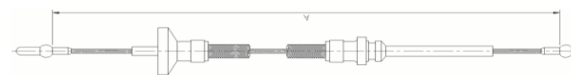
IMPORTANTE. Evite devoluciones o reclamos. Identifique previamente: marca, modelo y año del vehículo. En caso de duda, **CONSULTE** a su asesor.

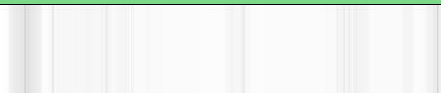
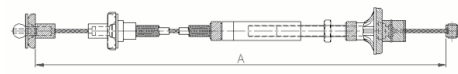
NUESTRA MISIÓN... Ser su aliado en el desarrollo y crecimiento de su negocio

Competimos directamente con los ORIGINALES

LINEA	CODIGO	MODELO	MOTOR	O.E.M	ARMADO	IMAGEN -- LONGITUD
PLYMOUTH - BREEZE						
EMBRAGUE	3808 CHREM	Breeze 1995-2000	L4 Cil. 2.0 L	04593333 04593103	EM112	 760mm
PLYMOUTH - HORIZON						
CONTROL CAMBIOS (Transversal)	3144 DODSC	Horizon 1983-1989 T/Estándar	L4 Cil. 2.2 L 2.6 L	4419831 4269853 4412669	SC54	 1195mm
EMBRAGUE	1655 DODE	Horizon 1982-1983	L4 Cil. 2.0 L	4505539 4369592	EM76	 1050mm
PLYMOUTH - LASER						
SELECTOR CAMBIOS (Selector)	3143 DODSC	laser 1984-1987 T Estandar	0	4419827	SC54	 1262mm
FRENO DE MANO	3683 MITFP	Laser 1988-1992	L4 Cil. 1.8 L	MB520483	FP351 Trasero Izquierdo	 1446mm
PLYMOUTH - PT CRUISER						
KIT CONTROL Y SELECTOR CAMBIOS	3398 DODCC	PT Cruiser 1995-1999 T/Estándar	0	4641135	CC40	 A=1222mm/B=1222mm
EMBRAGUE	3650 CHREM	PT Cruiser 1999-2001	L4 Cil. 2.0 L	4668999AC	EM112 Ajuste Manual	 840mm
PLYMOUTH - RELIANT						
SELECTOR CAMBIOS	2634 CHRSC	Reliant 1986-1990 T/Automática	L4 Cil. 2.2 L 2.5 L	4377303	SC24 Palanca al piso	 1422mm
SELECTOR CAMBIOS	2128 CHRSC	Reliant 1983 T/Automática		4269896, 4377317	SC26	 889mm
CONTROL CAMBIOS (Transversal)	3144 DODSC	Reliant 1983-1989 T/Estándar	L4 Cil. 2.2 L 2.6 L	4419831 4269853 4412669	SC54	 1195mm
PLYMOUTH - SUNDANCE						
CONTROL CAMBIOS (Transvesal)	3144 DODSC	Sundance 1983-1989 T/Estándar	L4 Cil. 2.2 L 2.6 L	4419831 4269853 4412669	SC54	 1195mm

Encino 1287 col. del Fresno Guadalajara Jal.

Tel. Multilínea (33) 3811 6917 - Serv. Cliente Cel. 33 1992 6768 - Guadalajara, Jalisco









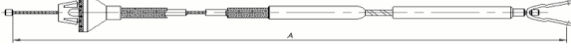
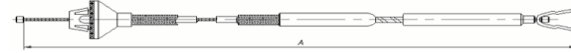
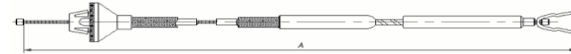
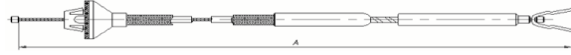

Correo: ventas@flexcontrol.com.mx - www.flexcontrol.com.mx - www.cablesnavcar.com

Automóvil - Suv - Van - Pickup - Camiones Pesados - Ligeros

IMPORTANTE. Evite devoluciones o reclamos. Identifique previamente: marca, modelo y año del vehículo. En caso de duda, **CONSULTE** a su asesor.

NUESTRA MISIÓN... Ser su aliado en el desarrollo y crecimiento de su negocio

Competimos directamente con los ORIGINALES

LINEA	CODIGO	MODELO	MOTOR	O.E.M	ARMADO	IMAGEN -- LONGITUD
PLYMOUTH - TRAILDUSTER						
ACELERADOR	1584 DODA	Trailduster 1978 - 1979	V6 Cil. 3.7 L	3820952	AC75	 695mm
	1790 DODAC	Trailduster 1978 - 1979	V8 Cil. 5.9 L	4088095	AC75	 620mm
	1581 DODA	Trailduster Todos 1981	V8 Cil. 5.2 L 5.9 L	4241224	AC77	 675mm
	1724 DODA	Trailduster 1980 - 1983	V8 Cil. 5.2 L	4275940	AC77	 695mm
PLYMOUTH - VALIANT						
ACELERADOR	146 DARA	Valiant 1968 - 1975	V6 Cil. 3.7 L	2899335	AC75	 620mm
	1566 DODA	Valiant 1976 - 1986	V6 Cil. 3.7 L	4027354	AC77	 620mm
PLYMOUTH - VOLARE						
EMBRAGUE	1655 DODE	Volare 1982-1983	L4 Cil. 2.0 L	4505539 4369592	EM76	 1050mm
	2286 DODEM	Volare 1984-1986	L4 Cil. 2.2 L	4369591	EM76	 1090mm
PLYMOUTH - VOYAGER						
SELECTOR CAMBIOS	3142 CHRSC	Voyager L, SE, LE 1990-1994 T/Estándar	L4 Cil. 2.5 L V6 Cil. 3.0 L	4446858 4504340	SC53	 1398mm
CONTROL CAMBIOS (Transversal)	3879 CHRCC	Voyager SE Station Wagon 1998 T/Estándar	0	0	SC53	 1300mm
CONTROL CAMBIOS (Transversal)	3144 DODSC	Voyager 1983-1989 T/Standar	L4 Cil. 2.2 L 2.6 L	4419831 4269853 4412669	SC54	 1195mm
EMBRAGUE	2288 CHREM	Voyager	V6 Cil. 3.3 L 3.8 L	0	EM76	 1472mm
ACELERADOR	2075 CHRAC	Voyager 1989	V6 Cil. 3.0 L	4459135	AC142	 948mm









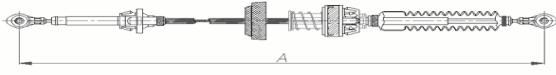
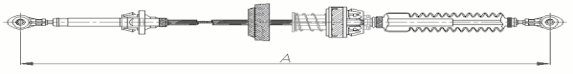

PONTIAC

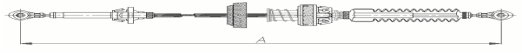
Automóvil - Suv - Van - Pickup - Camiones Pesados - Ligeros

¡IMPORTANTE! Evite devoluciones o reclamos. Identifique previamente: marca, modelo y año del vehículo. En caso de duda, **CONSULTE** a su asesor.

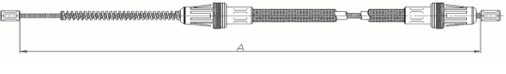
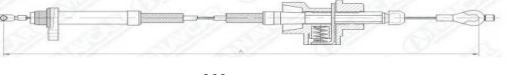
NUESTRA MISIÓN... Ser su aliado en el desarrollo y crecimiento de su negocio

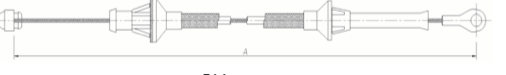
Competimos directamente con los ORIGINALES

LINEA	CODIGO	MODELO	MOTOR	O.E.M	ARMADO	IMAGEN -- LONGITUD
PONTIAC - AZTEK						
SELECTOR CAMBIOS	4247 GMCSC	Aztek 2001-2005 T/Automática	3.4L	21999431 12561101	SC140	 1856mm
PONTIAC - 6000						
SELECTOR CAMBIOS	2529 GMCSC	6000 THM440-T4, THM125 1986 - 1992 T/Automática	L4 Cil. 2.5 L V6 Cil. 2.8 L 3.3 L	10038603	SC29	 1508mm
	3416 GMCSC	6000 1986-1996 T/Automática	V6 Cil. 3.8 L	12552510	SC29	 1504mm
	3423 GMCSC	6000 1986-1987 T/Estándar	L4 Cil. 2.5 L V6 Cil. 2.8 L 3.3 L	2253553 2253554 2253555 10066450 14093374	SC68	 1278mm
PONTIAC - BONNEVILLE						
SELECTOR CAMBIOS	3097 GMCSC	Bonneville 1986-1993 T/Automática	V6 Cil. 3.8 L	25527523	SC29	 1352mm
	3645 GMCSC	Bonneville 2001 - 2005 T/Automática	V6 Cil. 3.8 L	15774348	SC68	 2108mm
	4040 GMCSC	Bonneville 1992-1999 T/Automática	V6 Cil. 3.8 L	25619416	SC67	 1395mm
	3644 GMCSC	Bonneville 2000 - 2005 T/Automática	V6 Cil. 3.5 L	15774347	SC68	 2240mm
FRENO DE MANO	2807 GMC FP	Bonneville 2001 - 2005	V6 Cil. 3.8 L V8 Cil. 4.6 L	25712419	FP239Trasero Derecho/Izquierdo	 749mm
SOBREMARCHA	2290 GMC SB	Boneville THM350C 1980	V8 Cil 5.7L	25503382	SB19	 960mm
SOBREMARCHA	2291 GMC SB	Bonneville w/200C 1985-1987	0	25521267	SB2	 786mm
ACELERADOR	2208 GMC AC	Beneville 200, 229, 262 1978-1987	V6 Cil. 3.8 L	1258156	AC231	 514mm
	3601 GMC AC	Boneville 1973	V8 Cil. 6.6 L 7.5 L	1244463, 1254179	AC263	 507mm
PONTIAC - FIERO						
SELECTOR CAMBIOS	3775 GMCSC	Fiero GT, SE, Sport 1986 - 1987 T/Standar	L4 Cil 2.5 L V6 Cil 2.8 L	10054258	SC75	 1871mm

Encino 1287 col. del Fresno Guadalajara Jal.



Tel: Multilínea (33) 3811 6917 - Serv. Cliente Cel: 33 1992 6768 - Guadalajara, Jalisco
Correo: ventas@flexcontrol.com.mx - www.flexcontrol.com.mx - www.cablesnavcar.com

Automóvil - Suv - Van - Pickup - Camiones Pesados - Ligeros



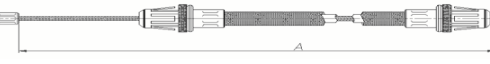

IMPORTANTE. Evite devoluciones o reclamos. Identifique previamente: marca, modelo y año del vehículo. En caso de duda, **CONSULTE** a su asesor.

NUESTRA MISIÓN... Ser su aliado en el desarrollo y crecimiento de su negocio



Competimos directamente con los ORIGINALES

LINEA	CODIGO	MODELO	MOTOR	O.E.M	ARMADO	IMAGEN -- LONGITUD
SELECTOR CAMBIOS (Selector)	3422 GMCS	Fiero Todos 1984 - 1986 T/Standar	L4 Cil. 2.5 L	10042386 10026619	SC69	 1645mm
FRENO DE MANO	2980 GMCFP	Fiero 1988	V6 Cil. 2.8 L	0	FP240 Trasero Izquierdo	 988mm
	2803 GMCFP	Fiero Sport, SE, GT 1984-1987	L4 Cil. 2.5 L	10055394	FP240 Trasero Derecho	 792mm

PONTIAC - FIREBIRD

SELECTOR CAMBIOS (Selector)	1763 GMCS	Firebird 1983 - 1986 T/Automatico	0	10232154, 10027632	SC11	 730mm
SOBREMARCHA	840 CHSB	Firebird TH700 1983-1987	0	25515598	SB2	 1060mm
	1621 GMSB	Firebird THM200C - THM700R4 1982 - 1983	0	25517311	SB2	 1335mm
	2292 GMCSB	Firebird 1982-1983	0	1644356	SB2	 575mm
	2297 GMCSB	Firebird THM700R4 1988-1989	0	10066475	SB2	 1050mm

PONTIAC - G6

FRENO DE MANO	3753 GMCFP	G6 GT Gas, G6 Base, G6 GXP 2004-2010	L4 Cil. 2.4 L V6 Cil. 3.5 L 3.6 L	20860176	FP370 Trasero Derecho	 2100mm
FRENO DE MANO	3747 GMCFP	G6 GT Gas, G6 Base, G6 GXP 2004-2010	L4 Cil. 2.4 L V6 Cil. 3.5 L 3.6 L	25974276	FP370 Trasero Izquierdo	 2101mm
SELECTOR CAMBIOS	4317 GMCS	G6 2005-2010 T/Automatica	2.4 L 3.5 L 3.6 L 3.9L	23238001	SC139	 1112mm

PONTIAC - GRAND AM

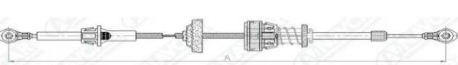



SELECTOR CAMBIOS	4246 CHES	Pontiac Grand AM 1999-2001 T/Automática	2.4L 3.4L	22678830	SC142	 2623mm
SELECTOR CAMBIOS	3584 AMCS	pontiac Grand AM 1997-1998 T/Automática	0	33004534	SC67	 2245mm

Automóvil - Suv - Van - Pickup - Camiones Pesados - Ligeros



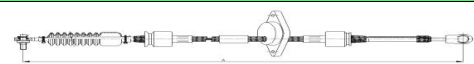

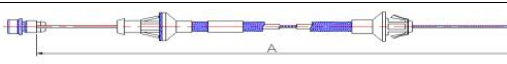
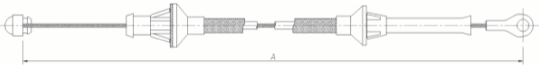
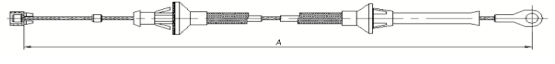

IMPORTANTE. Evite devoluciones o reclamos. Identifique previamente: marca, modelo y año del vehículo. En caso de duda, **CONSULTE** a su asesor.

NUESTRA MISIÓN... Ser su aliado en el desarrollo y crecimiento de su negocio

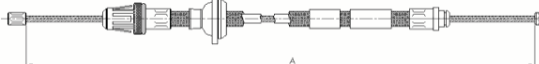
Competimos directamente con los ORIGINALES

LINEA	CODIGO	MODELO	MOTOR	O.E.M	ARMADO	IMAGEN -- LONGITUD
SELECTOR CAMBIOS (Selector)	3423 GMCSC	Grand Am, 1986-1987 T/Standar	L4 Cil. 2.5 L V6 Cil. 2.8 L 3.3 L	2253553 2253554 2253555 10066450 14093374	SC68	 1278mm
SELECTOR CAMBIOS (Selector)	3057 GMCSC	Grand AM 1988-1991 T/Standar	L4 Cil. 2.3 L	100779847 22539962	SC49	 1262mm
SELECTOR CAMBIOS (Selector)	3058 GMCSC	Grand AM 1988-1991 T/Standar	L4 Cil. 2.3 L	10079796 22539956	SC50	 1280mm
SELECTOR CAMBIOS (Selector)	3696 GMCSC	Gran AM 1992-1994 T/Standar	L4 Cil. 2.3 L	22575726	SC69	 1177mm
ACELERADOR	3560 GMCAC	Grand Am 1997-2004	V6 Cil. 3.3 L 3.8 L	22619741	AC258	 1427mm
	2208 GMCAC	Grand Am 1980-1981	V6 Cil. 3.8 L	1258156	AC231	 514mm
	353 ECAA	Grand Am 1975	V8 Cil. 6.6 L	1252955	AC1	 521mm

PONTIAC - GRAND PRIX





FRENO DE MANO	2806 GMCFP	Grand Prix 1977 - 2001	V6 Cil. 3.1 L 3.8 L	10306507	FP288 Principal	 2990mm
SELECTOR CAMBIOS	3446 GMCSC	Grand Prix 2002-2007 T/Automática	V6 Cil. 3.8 L V8 Cil. 5.3 L	15873762	SC58 Tramo Superior	 1872mm
	3449 GMCSC	Grand Prix 2002-2007 T/Automática	V6 Cil. 3.8 L V8 Cil. 5.3 L	15873759	SC57 Tramo Inferior	 1024mm
	3452 GMCSC	Grand Prix 2007 - 2011 T/Automática	V6 Cil. 3.8 L V8 Cil. 5.3 L	25940463	SC57 Tramo Inferior	 1020mm
CONJUNTO SELECTOR CAMBIOS	3455 GMCSC	Grand Prix 2002-2007 T/Automática	0	12458109	SC59	 2889mm
SOBREMARCHA	2034 GMCSCB	Grand Prix 1990 - 1993	0	10142050	SB2	 1243mm
	2038 GMCSCB	Grand Prix 1990 - 1993	0	24500492	SB2	 667mm

Automóvil - Suv - Van - Pickup - Camiones Pesados - Ligeros

IMPORTANTE. Evite devoluciones o reclamos. Identifique previamente: marca, modelo y año del vehículo. En caso de duda, **CONSULTE** a su asesor.

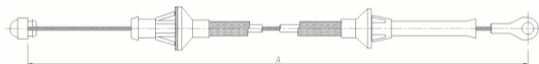
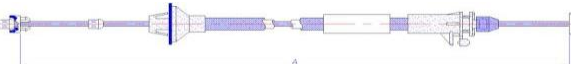
NUESTRA MISIÓN... Ser su aliado en el desarrollo y crecimiento de su negocio

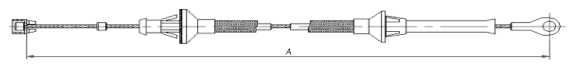

Competimos directamente con los ORIGINALES

LINEA	CODIGO	MODELO	MOTOR	O.E.M	ARMADO	IMAGEN -- LONGITUD
ACELERADOR	2208 GMCAC	Grand Prix 1986-1987	V6 Cil. 3.8 L	1258156	AC231	 514mm
	3448 GMCAC	Grand Prix 1993-1995	V6 Cil. 3.1 L	12554626	AC249	 943mm
	3559 GMCAC	Grand Prix 2000-2005	V6 Cil. 3.1 L	12567430	AC255	 1651mm
	3567 GMCAC	Grand Prix 1997 - 1999	V6 Cil. 3.3 L 3.8 L	12557988	AC254	 1646mm
	353 ECAA	Grand Prix 1975-1976	V8 Cil. 6.6 L	1252955	AC1	 521mm
	3450 GMCAC	Grand Prix 1998 - 2004	V6 Cil. 3.8 L	10332800	AC254	 1586mm



PONTIAC - MONTANA

SELECTOR Y CONTROL CAMBIOS	3814 GMCSC	Montana EXT, MPV SV-6; 2001-2009 T/Automática	V6 Cil. 3.4 L	103400403 12565602 15299671	SC70	 1558mm
----------------------------	----------------------	--	------------------	-----------------------------------	------	---

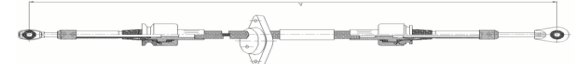
PONTIAC - SUNBIRD

SELECTOR CAMBIOS (Selector)	3700 GMCSC	Sunbird GT, LE 1992-1994 T/Standar	L4 Cil. 2.0 L 2.2 L V6 Cil. 3.1 L	22578976 22571779	SC69	 1242mm
SELECTOR CAMBIOS (Selector)	3696 GMCSC	Sunbird GT 1992-1994 T/Standar	L4 Cil. 2.3 L	22575726	SC69	 1177mm
SELECTOR CAMBIOS (Selector)	3057 GMCSC	Sunbird 1988-1991 T/Standar	L4 Cil. 2.3 L	100779847 22539962	SC49	 1262mm
SELECTOR CAMBIOS (Selector)	3058 GMCSC	Sunbird 1988-1991 T/Estándar	L4 Cil. 2.3 L	10079796 22539956	SC50	 1280mm

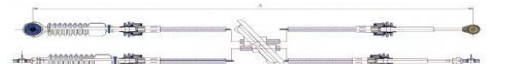
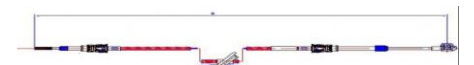
PONTIAC - SUNFIRE

KIT CONTROL Y SELECTOR CAMBIOS	3677 GMCCC	Sunfire 1996-1999 T/Standar	2.0 L 2.4 L	22650715	CC88	 A=1478mm B=1467mm
KIT CONTROL Y SELECTOR CAMBIOS	4149 CHECC	Sunfire 2000-2005 T/Standar	2.2 L	22707146	CC104	 A=1487mm/B=1445mm
	3561 GMCSC	Sunfire 1992 - 2002 T/Automática	L4 Cil. 2.2 L 2.4 L	22621784	SC70	 1344mm

Encino 1287 col. del Fresno Guadalajara Jal.

Automóvil - Suv - Van - Pickup - Camiones Pesados - Ligeros

IMPORTANTE. Evite devoluciones o reclamos. Identifique previamente: marca, modelo y año del vehículo. En caso de duda, **CONSULTE** a su asesor.

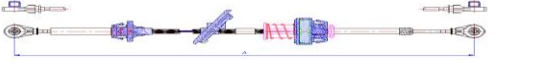
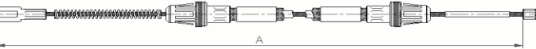

NUESTRA MISIÓN... Ser su aliado en el desarrollo y crecimiento de su negocio

Competimos directamente con los ORIGINALES

LINEA	CODIGO	MODELO	MOTOR	O.E.M	ARMADO	IMAGEN -- LONGITUD
SELECTOR CAMBIOS	3985 CHESC	Sunfire 1995-1998 T/Standar	2.4 L	22650715	SC91	 1517mm
	3815 GMSCC	Sunfire Convertible 1995 - 2005 T/Automática	L4 Cil. 2.2 L 2.4 L	22737100 22718296	SC70	 1297mm
FRENO DE MANO	2871 GMCFCP	Sunfire 1997-2002	L4 Cil. 2.2 L 2.4 L	22651234	FP220Trasero Derecho/ Izquierdo	 634mm

RENAULT







RENAULT - R-5

EMBRAGUE	307 EREE	R-5 Todos	0	7700653308	EM16	 646mm
FRENO DE MANO	1034 RENF	R-5 1980...	0	7701348487	FP40 Trasero Derecho	 1635mm
ACELERADOR	298 EREA	R-5 todos los s	L4 Cil. 1.6 L	7701348134	AC101	 1019mm

RENAULT - R-9

EMBRAGUE	22 RENE	R-9 Alliance Todos los s	0	7704001506	EM17	 1046mm
----------	-------------------	--------------------------------	---	------------	------	--

RENAULT - R-12

EMBRAGUE	24 RENE	R-12 1977 - 1981	0	7700549498	EM19	 847mm
	23 RENE	R-12 1973 - 1976	L4 Cil. 1.3 L	7701348399	EM19	 778mm
FRENO DE MANO	35 RENF	R-12 1973-1982	L4 Cil. 1.3 L	7701348283	FP45	 2115mm
FRENO DE MANO	36 RENF	R-12 1973-1982	L4 Cil. 1.3 L	7701348780	FP45	 2155mm
VELOCIMETRO	791 RENVZ	R-12 1973-1987	L4 Cil. 1.3 L	7701348732	VZ20 Terminal Roscado	 1575mm
	792 RENVZ	R-12 1978-1984	L4 Cil. 1.3 L	7700634922	VZ21	 1521mm

Encino 3287 col. del Fresno Guadalajara Jal.



Tel. Multilínea (33) 3811 6917 - Servi-Cliente Cel. 33 1992 6768 - Guadalajara, Jalisco
Correo: ventas@flexcontrol.com.mx - www.flexcontrol.com.mx - www.cablesnavcar.com

Automóvil - Suv - Van - Pickup - Camiones Pesados - Ligeros

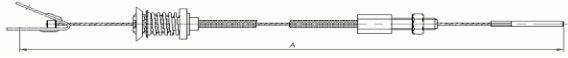
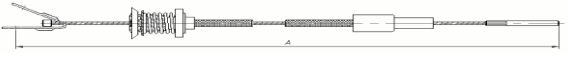

IMPORTANTE. Evite devoluciones o reclamos. Identifique previamente: marca, modelo y año del vehículo. En caso de duda, **CONSULTE** a su asesor.

NUESTRA MISIÓN... Ser su aliado en el desarrollo y crecimiento de su negocio



Competimos directamente con los ORIGINALES

LINEA	CODIGO	MODELO	MOTOR	O.E.M	ARMADO	IMAGEN -- LONGITUD
ACELERADOR	1855 RENAC	R-12 TS 1972 - 1976	L4 Cil. 1.3 L	7701348072	AC30 Con tornillo	 735mm
	1857 RENAC	R-12 TSP 1975 - 1980	L4 Cil. 1.3 L	7701348890	AC29 Presión	 735mm
	11 RENA	R-12 1975 - 1980	L4 Cil. 1.3 L	7701348444	AC28 Con tope	 894mm

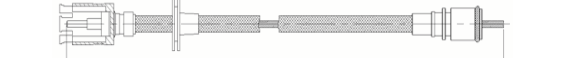
RENAULT R - 18

EMBRAGUE	306 EREE	R-18 1600 Todos	0	7704002290	EM168	 1525mm
	26 RENE	R-18 1984 - 1987	L4 Cil. 2.0 L	7704002286	EM20	 970mm
FRENO DE MANO	38 RENF	R-18 1981-1987	0	7704002268	FP40	 1152mm
VELOCIMETRO	792 RENVZ	R-18 1978-1984	L4 Cil. 1.3 L	7700634922	VZ21	 1521mm

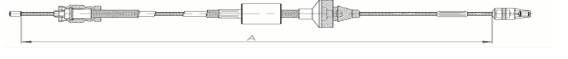
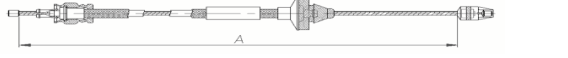
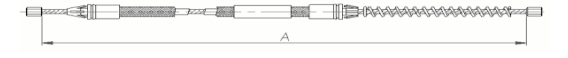
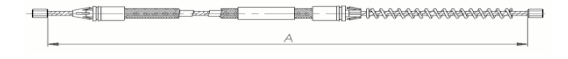
RENAULT - CLIO

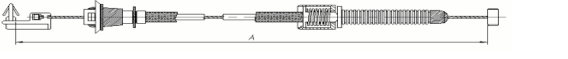

EMBRAGUE	2390 RENEM	Clio Fase I	L4 Cil. 1.2 L 1.5 L	7700809961	EM102	 986mm
	2138 RENEM	Clio Symbol todos	L4 Cil. 1.2 L 1.5 L	8200278120	EM89	 960mm
FRENO DE MANO	2017 RENFP	Clio Symbol 2000...	L4 Cil. 1.2 L	8200278126	FP186 Trasero Izquierdo	 1337mm
FRENO DE MANO	2018 RENFP	Clio Symbol 2000...	L4 Cil. 1.2 L	8200278128	FP186 Trasero Derecho	 1417mm
ACELERADOR	392 RENA	Clio RT 1996...	L4 Cil. 1.4 L	7700813980	AC95	 1275mm
	1000 RENA	Clio RN 1997	L4 Cil. 1.4 L	7700814767	AC24	 1275mm

Automóvil - Suv - Van - Pickup - Camiones Pesados - Ligeros



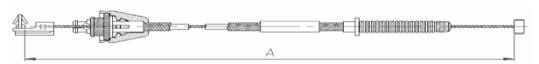
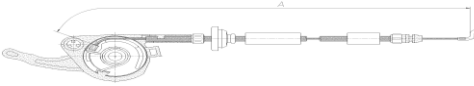

IMPORTANTE. Evite devoluciones o reclamos. Identifique previamente: marca, modelo y año del vehículo. En caso de duda, **CONSULTE** a su asesor.

NUESTRA MISIÓN... Ser su aliado en el desarrollo y crecimiento de su negocio

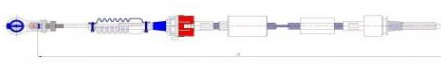
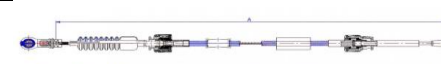

Competimos directamente con los ORIGINALES

LINEA	CODIGO	MODELO	MOTOR	O.E.M	ARMADO	IMAGEN -- LONGITUD
ACELERADOR	2136 RENAC	Clio Symbol 1999 - 2002	L4 Cil. 1.4 L	8200278139	AC154	 898mm
	2135 RENAC	Clio Symbol 2003...	L4 Cil. 1.4 L	8200278138A	AC153	 1330mm
APERTURA COFRE	3433 RENCA	Clio I - II 2012	V6 Cil. 3.7 L V8 Cil. 4.7 L	8200091632	CP30	 1993mm
	2935 RENCA	Clio Symbol Citius	V6 Cil. 2.7 L V8 Cil. 4.7 L	8200235412	CP20	 1978mm

RENAULT - DUSTER

KIT CONTROL Y SELECTOR CAMBIOS	3972 RENCC	Duster I 4X2 2012... T/Estándar	2.0L	349011155R 341080304R	CC85	 A=1137mm/B=1100mm
	3903 RENCC	Logan 2016..., T/Estándar	1.6L	349017122R	CC73	 A=944mm/B=1006mm
SELECTOR CAMBIOS	3899 RENSC	Duster 4x2 2012... T/Automática	2.0L 1.6L	8200785399	SC108	 1129mm
SELECTOR CAMBIOS	4203 RENCC	Duster Dynamique 4x3 2013	2.0L	0	CC97	 A=1133mm/B=1098mm
FRENO DE MANO	3891 RENFP	Duster 4x2 Todas 2013-2016	L4 Cil. 2.0 L	364009074R	FP198Trasero Derecho/Izquierdo	 1765mm

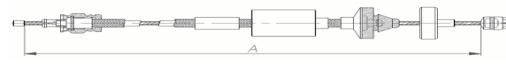
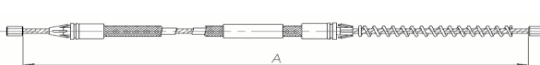
RENAULT - KANGOO

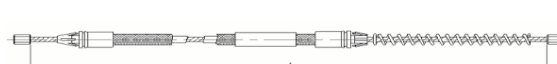
EMBRAGUE	2441 RENEM	Kangoo	L4 Cil. 1.2 L 1.4 L 1.6 L	7700417062	EM106	 951mm
FRENO DE MANO	3403 RENFP	Kangoo 2000...	L4 Cil. 1.2 L 1.4 L 1.6 L	7702307117A	FP186 Trasero Derecho	 1440mm
	3889 RENFP	Kangoo Todos	0	770031170A	FP186Trasero Derecho/ Izquierdo	 1433mm
	3404 RENFP	Kangoo 2000...	L4 Cil. 1.2 L 1.4 L 1.6 L	7702307081A	FP186 Trasero Izquierdo	 1425mm

Encino 3287 col. Del Fresno Guadalajara Jal.

Automóvil - Suv - Van - Pickup - Camiones Pesados - Ligeros



IMPORTANTE. Evite devoluciones o reclamos. Identifique previamente: marca, modelo y año del vehículo. En caso de duda, **CONSULTE** a su asesor.

NUESTRA MISIÓN... Ser su aliado en el desarrollo y crecimiento de su negocio

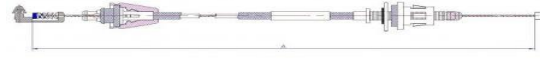

Competimos directamente con los ORIGINALES

LINEA	CODIGO	MODELO	MOTOR	O.E.M	ARMADO	IMAGEN -- LONGITUD
ACELERADOR	2451 RENAC	Kangoo 2003	L4 Cil. 1.4 L	0	AC154	 1130mm
	3920 RENAC	Kangoo Van-Cargo 2002-2014	L4 Cil. 1.6 L	7700427379	AC274	 516mm

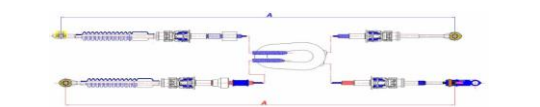
RENAULT KIWID

EMBRAGUE	4125 RENEM	Renaut Kwid 2009...	1.0L	307707842R	EM159	 925mm
FRENO DE MANO	4126 RENFP	Renaut Kwid 2019..	1.0L	365310042R	FP198 Trasero Izquierdo	 1487mm
	4127 RENFP	Renaut Kwid 2019..	1.0L	365303697R	FP198 Trasero Derecho	 1527mm
KIT CONTROL Y SELECTOR CAMBIOS	4174 RENCC	Renaut Kwid 2019..	1.0L	34935820R	CC110	 A=1086mm/B=1290mm

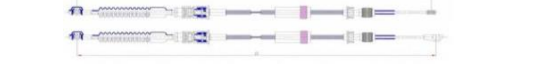
RENAULT - LOGAN

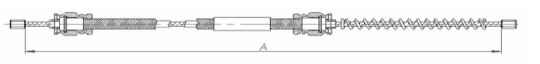
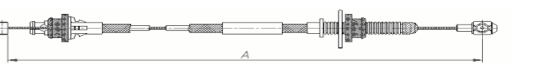
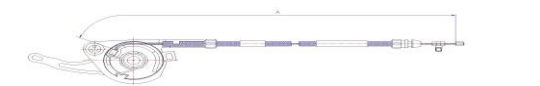
KIT CONTROL Y SELECTOR CAMBIOS	3903 RENCC	Logan 2016... T/Estándar	1.6L	349017122R	CC73	 A=944mm/B=1006mm
SELECTOR CAMBIOS	3899 RENSC	Logan 2012... T/Auotmatica	2.0L 1.6L	8200785399	SC108	 1129mm
EMBRAGUE	3893 RENEM	Logan 2005-2014	L4 Cil. 1.5 L 1.6 L	6001548445	EM144	 1127mm
FRENO DE MANO	2501 RENFP	Logan 2004...	L4 Cil. 1.2 L 1.4 L 1.6 L	6001547169 / 8200380738	FP198Trasero Derecho/Izquierdo	 1665mm
ACELERADOR	2639 RENAC	Logan 2004...	L4 Cil. 1.6 L	6001546868	AC219	 953mm
APERTURA COFRE	3432 RENCA	Logan 2012	L4 Cil. 1.6 L	6001547330	CP28	 1836mm

RENAULT MASTER

FRENO DE MANO	3959 RENFP	Master FG Confort 2003-2010	2.4L	7700311217 364000QAA	FP406 Trasero Derecho/Izquierdo	 1730mm
---------------	----------------------	-----------------------------------	------	-------------------------	------------------------------------	--





Encino 1287 col. del Fresno Guadalajara Jal.

Automóvil - Suv - Van - Pickup - Camiones Pesados - Ligeros

IMPORTANTE. Evite devoluciones o reclamos. Identifique previamente: marca, modelo y año del vehículo. En caso de duda, **CONSULTE** a su asesor.

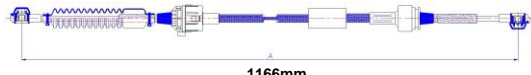
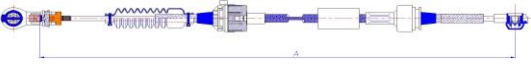
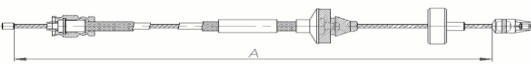
NUESTRA MISIÓN... Ser su aliado en el desarrollo y crecimiento de su negocio

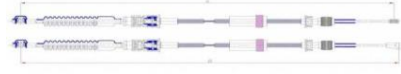
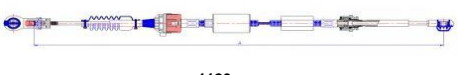
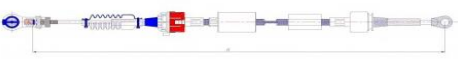
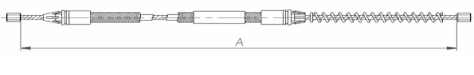
Competimos directamente con los ORIGINALES

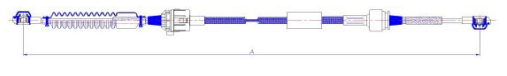
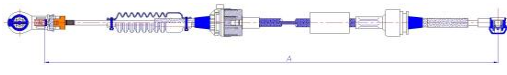
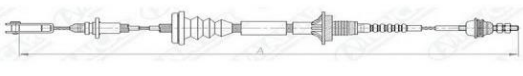





LINEA	CODIGO	MODELO	MOTOR	O.E.M	ARMADO	IMAGEN -- LONGITUD
RENAULT - MEGANE						
CONTROL CAMBIOS (Transversal)	3429 RENC	Megane II 2002... T/Standar	L4 Cil. 1.5 L 1.6 L 2.0 L	7701474699 314156687R	SC56	 1166mm
SELECTOR CAMBIOS (Selector)	3383 RENSC	Megane II 2002... T/Standar	L4 Cil. 1.5 L 1.6 L 2.0 L	7701474698 344453493R	CC39	 1041mm
EMBRAGUE	2147 RENEM	Megane II todos	0	8200278116	EM90	 965mm
APERTURA COFRE	3367 RENCA	Megane II	L4 Cil. 1.6 L	7700834378	CP28	 1880mm
RENAULT - SANDERO						
KIT CONTROL Y SELECTOR CAMBIOS	3903 RENC	Sandero 2016... T/Estándar	1.6L	349017122R	CC73	 A=944mm/B=1006mm
SELECTOR Y CONTROL CAMBIOS	3998 RENSC	Sandero 2008-2015 T/Automática	L4 Cil. 1.6 L	0	SC98	 1126mm
SELECTOR Y CONTROL CAMBIOS	3899 RENSC	Sandero 2012... T/Auotmatica	2.0L 1.6L	8200785399	SC108	 1129mm
FRENO DE MANO	3890 RENFP	Sandero Todos 2009-2015	L4 Cil. 1.2 L 1.4 L 1.6 L	8200745732	FP198Trasero Derecho/Izquierdo	 1680mm
ACELERADOR	3892 RENAC	Sandero (Stepway) 2009	L4 Cil. 1.6 L	182018832R	AC272	 1061mm
RENAULT - SCENIC						
CONTROL CAMBIOS (Transversal)	3429 RENC	Scenic II 2003... T/Standar	L4 Cil. 1.5 L 1.6 L 2.0 L	7701474699 314156687R	SC56	 1166mm
SELECTOR CAMBIOS (Selector)	3383 RENSC	Scenic II 2003... T/Standar	L4 Cil. 1.5 L 1.6 L 2.0 L	7701474698 344453493R	CC39	 1041mm
SUBARU						
SUBARU - LEGACY						
EMBRAGUE	2561 SUBEM	Legacy 1993-1995	L4 Cil. 1.8 L 2.2 L	37214AA080	EM115	 802mm

Automóvil - Suv - Van - Pickup - Camiones Pesados - Ligeros

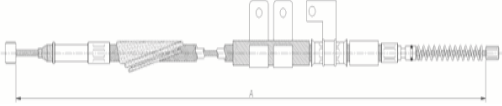
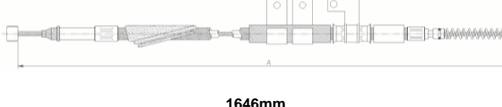
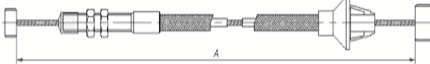
IMPORTANTE. Evite devoluciones o reclamos. Identifique previamente: marca, modelo y año del vehículo. En caso de duda, **CONSULTE** a su asesor.

NUESTRA MISIÓN... Ser su aliado en el desarrollo y crecimiento de su negocio

Competimos directamente con los ORIGINALES

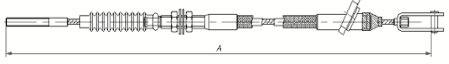
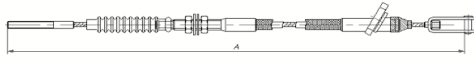





LINEA	CODIGO	MODELO	MOTOR	O.E.M	ARMADO	IMAGEN -- LONGITUD
FRENO DE MANO	3184 SUBFP	Legacy 1990-1994	L4 Cil. 1.8 L 2.0 L 2.4 L 3.0 L	0	FP323 Trasero Izquierdo	 1646mm
SUBARU - OUTDOOR						
FRENO DE MANO	3184 SUBFP	Outdoor 1990-1994	L4 Cil. 1.8 L 2.0 L 2.4 L 3.0 L	0	FP323 Trasero Izquierdo	 1646mm
SUBARU - SEDAN						
ACELERADOR	263 SUBA	Sedan 1980 - 1984	L4 Cil. 1.6 L	737065251	AC97	 912mm
SUZUKI						
SUZUKI - ESTEEM						
EMBRAGUE	1662 CHEE	Esteem (Baleno) 1999...	L4 Cil. 1.6 L	2371060631	EM12	 627mm
SUZUKI - GRAND VITARA						
SELECTOR Y CONTROL CAMBIOS	3958 SUZCC	Grand Vitara 2008-2011 T/Automática	V6 Cil. 2.7 L	2821665J111	CC77	 1249mm
FRENO DE MANO	2011 GMCFP	Grand Vitara 5 Puertas 1998...	0	5441065D10	FP34Trasero Derecho/Izquierdo	 1628mm
ACELERADOR	2724 GMCAC	Grand Vitara 2000	L4 Cil. 1.6 L 2.0 L 2.5 L	1591067D10 1591067D50	AC19	 952mm
SOBREMARCHA	4276 GMCSCB	Grand Vitara 2006-2011	2.7L 2.5L 2.0 L	0	SB27	 1032mm
APERTURA COFRE	2858 GMCCA	Grand Vitara todos	L4 Cil. 1.6 L 2.0 L 2.5 L	8216065D00	CP9	 1797mm
SUZUKI - SAMURAI						
EMBRAGUE	2499 SUZEM	Samurai 1986-1988	L4 Cil. 1.3 L	2371083023	EM9	 1902mm
	375 SAME	Samurai 1991...	L4 Cil. 1.3 L	2371083024	EM9	 1898mm

Automóvil - Suv - Van - Pickup - Camiones Pesados - Ligeros

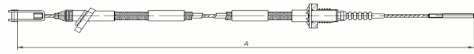
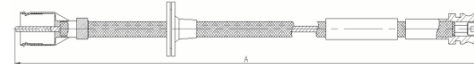
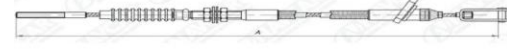
IMPORTANTE. Evite devoluciones o reclamos. Identifique previamente: marca, modelo y año del vehículo. En caso de duda, **CONSULTE** a su asesor.

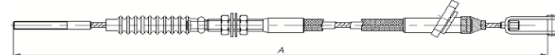
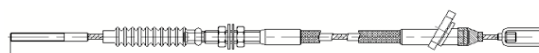
NUESTRA MISIÓN... Ser su aliado en el desarrollo y crecimiento de su negocio

Competimos directamente con los ORIGINALES

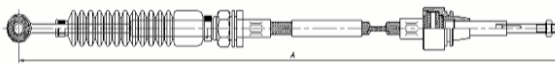
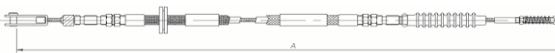
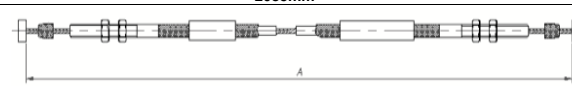
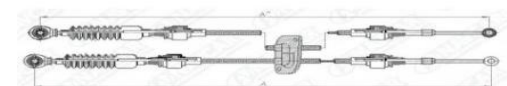

LINEA	CODIGO	MODELO	MOTOR	O.E.M	ARMADO	IMAGEN -- LONGITUD
	2498 SUZEM	Samurai 1 1992-1996	L4 Cil. 1.3 L	2371057B10 2371057B11 2371057B12	EM13	 1869mm
VELOCIMETRO	1113 GMCVZ	Samurai 1990...	L4 Cil. 2.0 L	3491080031	VZ9	 2252mm
SUZUKI - SIDEKICK						
EMBRAGUE	2497 SUZEM	Sidekick 1989 - 1991	L4 Cil. 1.3 L 1.6 L	2371063A10	EM9	 1862mm
	2498 SUZEM	Sidekick 1992 - 1996	L4 Cil. 1.3 L	2371057B10 2371057B11 2371057B12	EM13	 1869mm
SUZUKI - SJ 413						
EMBRAGUE	274 SUZE	SJ-413 1987...	L4 Cil. 1.0 L	2371083024	EM9	 1898mm
	2499 SUZEM	SJ-413 Santana (Canadá) 1985-1988	L4 Cil. 1.3 L	2371083023	EM9	 1902mm
SUZUKI - SPRINT						
EMBRAGUE	1759 GMCEM	Sprint 1985 - 1988	L4 Cil. 1.0 L	2371082064	EM10	 618mm
	547 SWIE	Sprint Forsa II 1991-1993	3 Cil. 1.0 L	2371060B10	EM12	 627mm
ACELERADOR	810 SWIA	Sprint Forsa II 1991...	L4 Cil. 1.6 L	1591063B21	AC19	 613mm
SUZUKI - SUPER CARRY						
SELECTOR CAMBIOS (Selector)	1156 CARS	Super Carry 1994... T/Standar	L4 Cil. 1.0 L	2838085201	SC4	 1085mm
EMBRAGUE	202 CARE	Super Carry 1994...	L4 Cil. 1.0 L	2371085232	EM11	 2085mm
ACELERADOR	141 CARA	Super Carry 1994...	L4 Cil. 1.6 L	1591085211	AC18	 1800mm
SUZUKI - SWIFT						
KIT CONTROL Y SELECTOR CAMBIOS	2571 GMCCC	Swift 2002-2006	1.6L	2838070C01	CC27	 A=1084mm/B=1135mm

Automóvil - Suv - Van - Pickup - Camiones Pesados - Ligeros



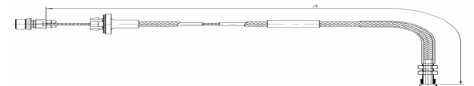
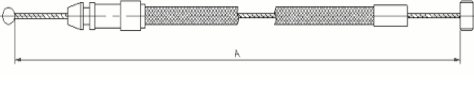

IMPORTANTE. Evite devoluciones o reclamos. Identifique previamente: marca, modelo y año del vehículo. En caso de duda, **CONSULTE** a su asesor.

NUESTRA MISIÓN... Ser su aliado en el desarrollo y crecimiento de su negocio

Competimos directamente con los ORIGINALES

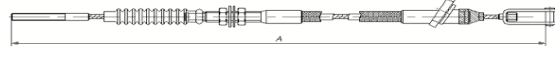
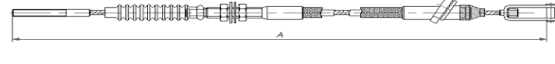
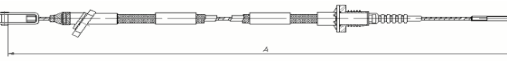
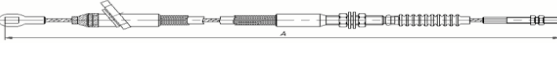
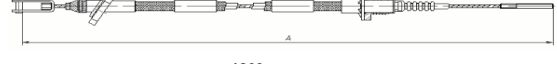
LINEA	CODIGO	MODELO	MOTOR	O.E.M	ARMADO	IMAGEN -- LONGITUD
EMBRAGUE	547 SWIE	Swift 1993...	3 Cil. 1.0 L	2371060B10	EM12	 627mm
	349 SWIE	Swift 1992...	L4 Cil. 1.3 L	2371063B10 30015828	EM12	 591mm
ACELERADOR	810 SWIA	Swift 1996...	L4 Cil. 1.6 L	1591063B21	AC19	 613mm
	339 SWIA	Swift GTI 1991...	L4 Cil. 1.3 L	1591064B02	AC19	 713mm
APERTURA COFRE	83 SWIC	Swift 1991...	L4 Cil. 1.3 L	8216060B00	CP4 Sin Manija	 1818mm

SUZUKI - TRACKER

SELECTOR Y CONTROL CAMBIOS	3958 SUZCC	Tracker 2008-2011 T/Automática	V6 Cil. 2.7 L	2821665J111	CC77	 1249mm
EMBRAGUE	2499 SUZEM	Tracker 1986-1988	L4 Cil. 1.3 L	2371083023	EM9	 1902mm
	375 SAME	Tracker 1991...	L4 Cil. 1.3 L	2371083024	EM9	 1898mm
	1400 VITE	Tracker 1992-1997	L4 Cil. 1.6 L	2371057B12	EM13 Con Tope	 1866mm
	205 SUZE	Tracker 1994-1995	L4 Cil. 1.6 L	2371080420 23710 80021	EM59 Con Tornillo	 1698mm
EMBRAGUE	2498 SUZEM	Tracker 1992-1996	L4 Cil. 1.3 L	2371057B10 /2371057B11 /2371057B12	EM13	 1869mm
VELOCIMETRO	699 GMCVZ	Tracker 1985-1998.	L4 Cil. 2.0 L	3491060A41	VZ13	 2513mm
	768 SUZVZ	Tracker 1987....	L4 Cil. 2.0 L	3491080030	VZ60	 2355mm
ACELERADOR	175 SAMA	Tracker 1986 - 1990	L4 Cil. 1.6 L	15910-83300	AC16	 1082mm

Automóvil - Suv - Van - Pickup - Camiones Pesados - Ligeros



IMPORTANTE. Evite devoluciones o reclamos. Identifique previamente: marca, modelo y año del vehículo. En caso de duda, **CONSULTE** a su asesor.

NUESTRA MISIÓN... Ser su aliado en el desarrollo y crecimiento de su negocio

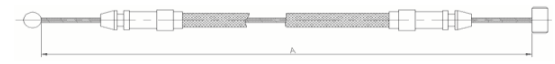
Competimos directamente con los ORIGINALES

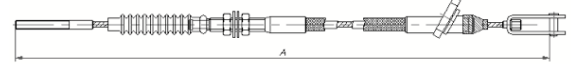

LINEA	CODIGO	MODELO	MOTOR	O.E.M	ARMADO	IMAGEN -- LONGITUD
APERTURA COFRE	3780 GMCCA	Tracker 1999-2006	L4 Cil. V6 Cil.	0	CP9	 1800mm

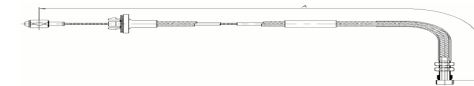
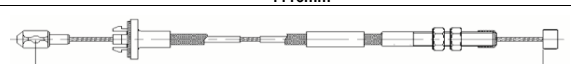
SUZUKI - VITARA



EMBRAGUE	933 VITE	Vitara 1991...	V6 Cil. 2.5 L	2371060A11	EM163	 1887mm
SOBREMARCHA	1994 GMCSB	Vitara 1990-1996	0	2475157B01	SB27	 1004mm
ACELERADOR	3578 GMCAC	Vitara 2000-2012	L4 Cil. 1.6 L	1591063A0V	AC17	 1116mm
	329 VITA	Vitara Sidekick 1992...	L4 Cil. 2.0 L	1591057B11	AC20	 885mm

TOYOTA

TOYOTA - 4 RUNNER

SOBREMARCHA	1274 TOSB	4 Runner T/A340 1988-1995 T/Automática	0	3552035050	SB15	 1717mm
FRENO DE MANO	3737 TOYFP	X-Runner Pre-Runner Gasolina 2005 - 2014	4.0L	46420-04110	FP365 Trasero Derecho	 2771mm
SELECTOR CAMBIOS	4362 TOYSC	Runner 2003-2016	3.0L 4.0L	33820-60070	SC164	 1557mm

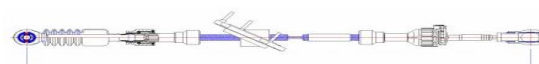
TOYOTA - CAMRY

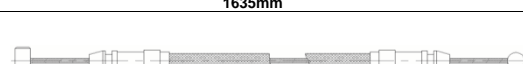







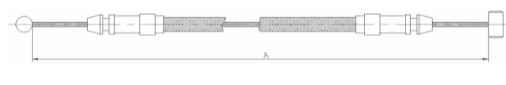
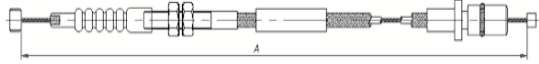

SELECTOR CAMBIOS	4160 TOYSC	Camry 2002-2006	2.4L	33822-33080	SC123	 1219mm
CONTROL CAMBIOS (Transversal)	4161 TOYCC	Camry 2002-2006 T/Estandar	2.4L	3382133170	CC107	 1278mm
SELECTOR CAMBIOS	1679 TOSE	Camry 1992 - 1999 T/Automática	L4 Cil. 1.4 L 2.0 L	3382032161	SC10	 1635mm
APERTURA	276 TOYC	Camry 1992 - 1995	V6 Cil. 2.7 L V8 Cil. 4.7 L	5363033010	CP9 Sin manija	 2010mm

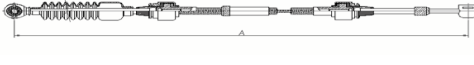
Automóvil - Suv - Van - Pickup - Camiones Pesados - Ligeros

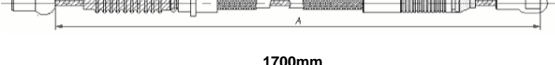
IMPORTANTE. Evite devoluciones o reclamos. Identifique previamente: marca, modelo y año del vehículo. En caso de duda, **CONSULTE** a su asesor.

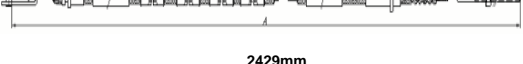
NUESTRA MISIÓN... Ser su aliado en el desarrollo y crecimiento de su negocio

Competimos directamente con los ORIGINALES









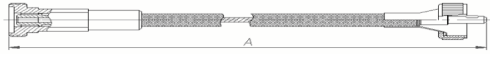

LINEA	CODIGO	MODELO	MOTOR	O.E.M	ARMADO	IMAGEN -- LONGITUD
COFRE	275 TOYC	Camry 1987 - 1991	V6 Cil. 2.7 L	53630-32060	CP9	 2193mm
			V8 Cil. 4.7 L		Sin manija	
TOYOTA - CELICA						
SOBREMARCHA	3719 TOYSB	Celica 1986-1987	L4 Cil. 2.0 L	35520-20161	SB13	 1033mm
ACELERADOR	2343 TOYAC	Celica GT 5SFE w/o CC 1990 - 1991	L4 Cil. 2.0 L	781802B400	AC50	 1782mm
TOYOTA - COROLLA						
SELECTOR CAMBIOS (Selector)	1681 TOSE	Corolla 1988 - 1992 T/Standar	L4 Cil. 1.6 L	3382112470	SC8	 1203mm
SELECTOR CAMBIOS (Selector)	1682 TOSE	Corolla 1993 - 1997 T/Estándar	L4 Cil. 1.6 L 1.8 L	3382112301	SC8 Con pesa	 1185mm
EMBRAGUE	248 TOYE	Corolla KM20 1979	L4 Cil. 1.6 L	3134029085	EM37	 2512mm
	633 TOYE	Corolla KE70 1980...	L4 Cil. 1.6 L	3134019225	EM36	 1700mm
	99 TOYE	Corolla KE 10-11 1966 - 1970	L4 Cil. 1.6 L	3134019105	EM35	 1541mm
	947 TOYE	Corolla 3K 1988	L4 Cil. 1.6 L	3134027121	EM38	 2429mm
FRENO DE MANO	1949 TOYFP	Corolla KE10 / KE20 - 26 1966 - 1970 1970 - 1974	0	4641012010J	FP127 Principal	 281mm
	3749 TOYFP	Corolla S, LE, CE 2003-2004	L4 Cil. 1.8 L	46420-02070	FP371 Trasero Derecho	 1702mm
FRENO DE MANO	3750 TOYFP	Corolla S, LE, CE 2003-2004	L4 Cil. 1.8 L	46430-02070	FP372 Trasero Izquierdo	 1636mm
SOBREMARCHA	2508 TOYSB	Corolla Motor 22F 1998-2000,	L4 Cil. 1.8 L	3552012450 3552012500	SB35	 1198mm

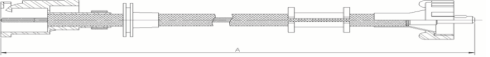
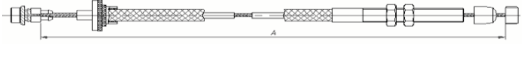
Automóvil - Suv - Van - Pickup - Camiones Pesados - Ligeros

IMPORTANTE. Evite devoluciones o reclamos. Identifique previamente: marca, modelo y año del vehículo. En caso de duda, **CONSULTE** a su asesor.

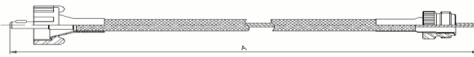
NUESTRA MISIÓN... Ser su aliado en el desarrollo y crecimiento de su negocio

Competimos directamente con los ORIGINALES

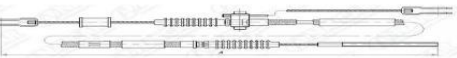
LINEA	CODIGO	MODELO	MOTOR	O.E.M	ARMADO	IMAGEN -- LONGITUD
VELOCIMETRO	2696 TOVYZ	Corolla 1988-1993	L4 Cil. 1.8 L	83710122581	VZ83 Tramo Superior	 322mm
	1680 TOVYZ	Corolla AE92,CE90 / AE92, CE90 1987-1993	L4 Cil. 1.8 L	8371012460 8371012641	VZ64	 272mm
	759 TOVYZ	Corolla 1989 - 1991	L4 Cil. 1.8 L	8371012320	VZ12	 837mm
ACELERADOR	2722 TOYAC	Corolla 1991-1992	L4 Cil. 1.6 L	781801A350	AC114	 700mm
	1173 TOYA	Corolla AE101 1992-1997	L4 Cil. 1.8 L	781801A560	AC50	 933mm
	1479 TOYA	Corolla EE90 1987...	L4 Cil. 1.8 L	781801A200	AC114	 1285mm
APERTURA COFRE	1190 TOYC	Corolla AE101 - CE100 - EE100 - 105 1992...	V6 Cil. 1.7 L V8 Cil. 4.7 L	5363012460	CP9	 2042mm
TOYOTA - CORONA						
VELOCIMETRO	2537 TOVYZ	Corona 1968 - 1973	L4 Cil. 1.8 L	8371019115	VZ3	 1676mm
TOYOTA - CRESSIDA						
ACELERADOR	304 TOYA	Cressida 1986 - 1988	V6 Cil. 2.8 L	7818022481D	AC230	 764mm
TOYOTA - EFI						
KIT CONTROL Y SELECTOR CAMBIOS	2567 TOYCC	EFI 1988-1992 T/Standar	0	0	CC28	 A=1364mm/B=1330mm
TOYOTA - HIACE						
KIT CONTROL Y SELECTOR CAMBIOS	4166 TOYCC	Hi-Ace 4RB2 TRH213-TRH223 2005 - 2015	2.7L	3382026373	CC108	 A=2598mm/B=2674mm
FRENO DE MANO	3516 TOYFP	Hi ace 2005 - 2015	0	4643026450	FP342 Trasero Izquierdo	 2346mm
	3526 ESP	Hi ace 2005...	L4 Cil. 2.2 L 2.4 L	0	FP12 Trasero Único	 2567mm

Encino 1287 col. del Fresno Guadalajara Jal.





Tel. Multlínea (33) 3811 6917 - Serv. Cliente Cel. 33 1992 6768 - Guadalajara, Jalisco
Correo: ventas@flexcontrol.com.mx - www.flexcontrol.com.mx - www.cablesnavcar.com

Automóvil - Suv - Van - Pickup - Camiones Pesados - Ligeros



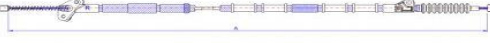

IMPORTANTE. Evite devoluciones o reclamos. Identifique previamente: marca, modelo y año del vehículo. En caso de duda, **CONSULTE** a su asesor.

NUESTRA MISIÓN... Ser su aliado en el desarrollo y crecimiento de su negocio

Competimos directamente con los ORIGINALES

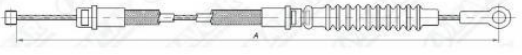
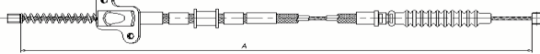
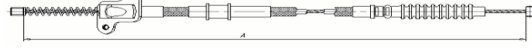
LINEA	CODIGO	MODELO	MOTOR	O.E.M	ARMADO	IMAGEN -- LONGITUD
FRENO DE MANO	3563 TOYFP	Hi ace 2007...	0	0	FP341 Trasero Derecho	 2740mm
	3991 TOYFP	Hi ace 2005- 2015	0	46420-26450	FP417 Trasero Derecho	 3312mm
FRENO DE MANO	2651 TOYFP	Hi ace 2006 - 2008	0	0	FP238 Central	 2017mm
FRENO DE MANO	3515 TOYFP	Hi ace 2005....	0	4642026611	FP341 Trasero Derecho	 2574mm
FRENO DE MANO	3564 TOYFP	Hi ace 2007...	0	0	FP342 Trasero Izquierdo	 1810mm
VELOCIMETRO	1962 TOYVZ	Hi ace	0	8371087336	VZ12	 3517mm

TOYOTA - HILUX

FRENO DE MANO	1221 TOYF	Hilux Vzn30 1988...	L4 Cil. 2.0 L 2.5 L 2.8 L	4641035650	FP78 Principal	 1942mm
	1708 TOYF	Hilux		4643035152	FP140 Trasero Izquierdo	 1920mm
	1707 TOYF	Hilux		4642035142	FP139 Trasero Derecho	 1925mm
	2370 TOYFP	Hilux 1998...	L4 Cil. 1.8 L	0	FP140 Trasero Izquierdo (Ajustable para Ensamblar sin Troquelar)	 2540mm
	2371 TOYFP	Hilux 1998...	L4 Cil. 1.8 L	0	FP139 Trasero Derecho (Ajustable para Ensamblar sin Troquelar)	 2540mm
	2368 TOYFP	Hilux Cabina simple 1984 - 1990	L4 Cil. 1.8 L	0	FP140 Trasero Izquierdo	 1736mm

Encino 1287 col. del Fresno Guadalajara Jal.





Tel. Multilínea (33) 3811 6917 - Servi-Cliente Cel. 33 1992 6768 - Guadalajara, Jalisco
Correo: ventas@flexcontrol.com.mx - www.flexcontrol.com.mx - www.cablesnavcar.com

Automóvil - Suv - Van - Pickup - Camiones Pesados - Ligeros

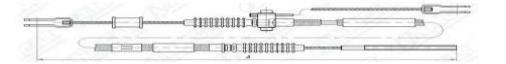
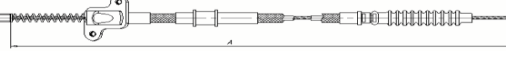

IMPORTANTE. Evite devoluciones o reclamos. Identifique previamente: marca, modelo y año del vehículo. En caso de duda, **CONSULTE** a su asesor.

NUESTRA MISIÓN... Ser su aliado en el desarrollo y crecimiento de su negocio



Competimos directamente con los ORIGINALES

LINEA	CODIGO	MODELO	MOTOR	O.E.M	ARMADO	IMAGEN -- LONGITUD
FRENO DE MANO	2921 TOYFP	Hilux KUN 25, 26 4x4 2004...	L4 Cil. 2.0 L 2.5 L 2.8 L	464200K041	FP289 Trasero Derecho	 1365mm
	3527 ESP	HILUX (REFA-042) 2000,	L4 Cil. 2.0 L 2.5 L 2.8 L	0	FP125 Trasero Único	 2464mm
	2369 TOYFP	Hilux Cabina simple 1984 - 1990	L4 Cil. 1.8 L	0	FP139 Trasero Derecho	 1780mm
ACELERADOR	3397 TOYAC	Hilux 22R Fuel Injection 1988-99	2.4L 3.0L	7818035052 7818004040 7818035050 7818089154	AC50	 1020mm
ACELERADOR	1709 TOYA	Hilux RN 50 - 60 1983 - 1986	0	78180-89133	AC50	 945mm
ACELERADOR	1174 TOYA	Hilux VZN130 1989...,	0	7818089160	AC50	 1126mm

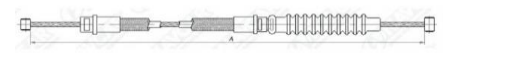
TOYOTA - HILUX 22R

FRENO DE MANO	1475 TOYF	Hilux RN50-22R versión americana 1989...	L4 Cil. 2.2 L 2.4 L	4643035171	FP140 Trasero Izquierdo	 1960mm
FRENO DE MANO	1474 TOYF	Hilux RN50-22R version americana 1989...,	L4 Cil. 2.2 L 2.4 L	4642035171 46420-35340	FP139 Trasero Derecho	 1708mm
FRENO DE MANO	1415 TOYF	22R Rn85 Ln81 Yn65 4X2 - 4X4 1985-1986 Cabina Estándar	2.4L	4641035710	FP77 Principal	 1188mm

TOYOTA - HILUX 4x2

FRENO DE MANO	1449 TOYF	Hilux 4x2 Cabina simple 1995...	L4 Cil. 2.2 L 2.4 L	4643035440	FP138 Trasero Izquierdo	 1951mm
FRENO DE MANO	1448 TOYF	Hilux 4x2 Cabina simple 1995...	L4 Cil. 2.2 L 2.4 L	4642035580	FP137 Trasero Derecho	 1951mm

TOYOTA - HILUX Series LN

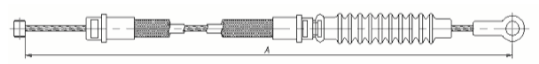
	1222 TOYF	Hilux LN111 1988...	L4 Cil. 3.0 L	4641035580	FP78 Principal	 2394mm
--	---------------------	---------------------------	------------------	------------	-------------------	--

Encino 1287 col. del Fresno Guadalajara Jal.



Tel: Multlínea (33) 3811 6917 - Serv. Cliente Cel: 33 1992 6768 - Guadalajara, Jalisco
Correo: ventas@flexcontrol.com.mx - www.flexcontrol.com.mx - www.cablesnavcar.com

Automóvil - Suv - Van - Pickup - Camiones Pesados - Ligeros

IMPORTANTE. Evite devoluciones o reclamos. Identifique previamente: marca, modelo y año del vehículo. En caso de duda, **CONSULTE** a su asesor.

NUESTRA MISIÓN... Ser su aliado en el desarrollo y crecimiento de su negocio

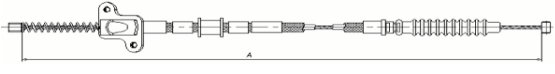
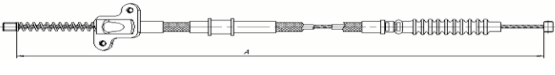
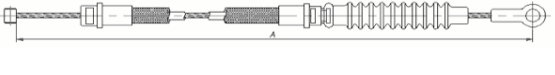
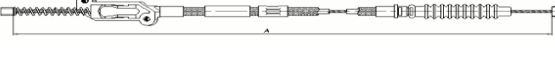
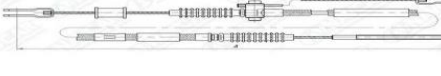
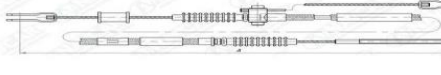
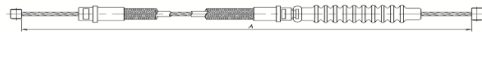
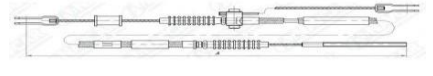
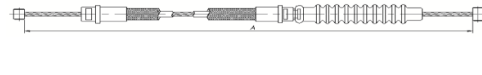
Competimos directamente con los ORIGINALES

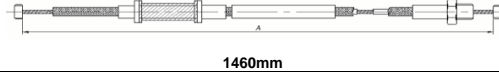
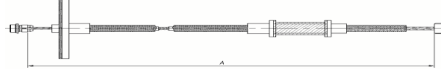
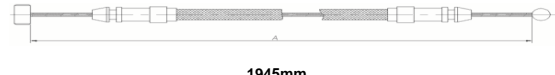
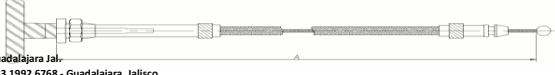





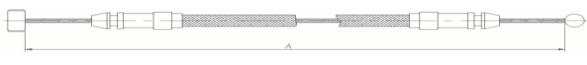
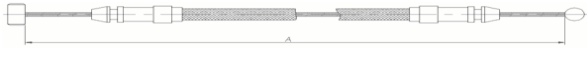
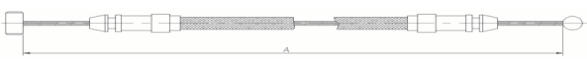
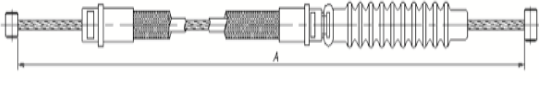
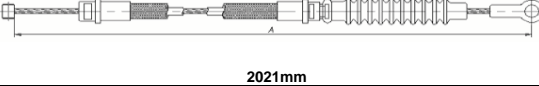
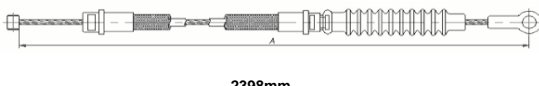

LINEA	CODIGO	MODELO	MOTOR	O.E.M	ARMADO	IMAGEN -- LONGITUD
FRENO DE MANO	1919 TOYFP	Hilux LN145 - RZN 147 1998...	L4 Cil. 2.5 L	4643035530	FP140 Trasero Izquierdo	 2024mm
	1918 TOYFP	Hilux LN145 - RZN 147 1998...	L4 Cil. 2.5 L	4642035690	FP139 Trasero Derecho	 2012mm
	2115 TOYFP	Hilux LN166, 191, RZN	L4 Cil. 2.0 L 2.5 L 2.8 L	4641035830	FP78 Principal	 2187mm
	1201 TOYF	Hilux LN50-51 1983 - 1988	L4 Cil. 2.5 L	4643035210	FP75 Trasero Izquierdo	 1717mm
	1215 TOYF	Hilux LN100-106 - YN100- 105 1988 - 1997	L4 Cil. 2.0 L 2.5 L 2.8 L	4642035490	FP125 Trasero Único	 2324mm
	1216 TOYF	Hilux LN107-111 - RN106- 110 1988 - 1999	L4 Cil. 2.0 L 2.5 L 2.8 L	4642035500	FP125 Trasero Único	 2353mm
	2461 TOYFP	Hilux LN50, 55, YN50, 55 1983 - 1992	L4 Cil. 2.5 L	4641035320	FP77 Principal	 1226mm
	2918 TOYFP	Hilux LN60-65 YN60-65 1983-1988	L4 Cil. 2.0 L 2.5 L 2.8 L	4642035250	FP125 Ref tubo Int Nylon	 2345mm
	2462 TOYFP	Hilux LN85, YN80, 85,,, Traccion 2R - 1988 - 1991	L4 Cil. 2.5 L	4641035500	FP77 Principal	 1180mm
VELOCIMETRO	1776 TOYVZ	Hilux LN 36 - 48 1981 - 1983	0	8371095116	VZ12	 1972mm
ACELERADOR	549 TOYA	Hilux LN30-40 1981 - 1983	L4 Cil. 2.2 L 2.4 L	7818089126	AC54	 1460mm
	1047 TOYA	Hilux LN50-56-57-60 1983 - 1988	L4 Cil. 2.4 L	7818089134	AC57	 1088mm
	1900 TOYCA	Hilux LN140, 145 - RZN142 - YN140 1997...	V6 Cil. 1.7 L V8 Cil. 4.7 L	5363035050	CP9	 1945mm
	3369 TOYCA	Hilux LN30-46, RN30-46 1978 - 1984	V6 Cil. 3.7 L V8 Cil. 4.7 L	5363089106	CP7	 1636mm

Automóvil - Suv - Van - Pickup - Camiones Pesados - Ligeros

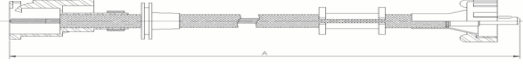
IMPORTANTE. Evite devoluciones o reclamos. Identifique previamente: marca, modelo y año del vehículo. En caso de duda, **CONSULTE** a su asesor.

NUESTRA MISIÓN... Ser su aliado en el desarrollo y crecimiento de su negocio

Competimos directamente con los ORIGINALES

LINEA	CODIGO	MODELO	MOTOR	O.E.M	ARMADO	IMAGEN -- LONGITUD
APERTURA COFRE	3370 TOYCA	Hilux LN50-60, YN50-56 1983 - 1988	V6 Cil. 3.7 L V8 Cil. 4.7 L	5363089111 5363089109	CP9	 1780mm
	277 TOYC	Hilux LN80-106 1992 -1999	V6 Cil. 2.7 L V8 Cil. 4.7 L	5363089114	CP9 Sin manija	 1873mm
	3368 TOYCA	Hilux LN80-106, YN80-105 1988 - 1997	V6 Cil. 2.7 L V8 Cil. 4.7 L	5363089113	CP9	 1872mm
TOYOTA - HILUX Series RN						
FRENO DE MANO	1040 TOYF	Hilux RN 30 - LN 30 1978 - 1983	L4 Cil. 2.0 L 2.5 L 2.8 L	4641035151	FP77 Principal	 1211mm
	1042 TOYF	Hilux RN 65 1983 - 1985	L4 Cil. 2.0 L 2.5 L 2.8 L	4641035250	FP78 Principal	 2021mm
	2919 TOYFP	Hilux RN110 YN110 LHD 1988-1997	L4 Cil. 2.0 L 2.5 L 2.8 L	4641035570	FP78 Principal	 2398mm
VELOCIMETRO	1495 TOYVZ	Hilux RN106 4x4 - YN106 1988 - 1999	0	8371089185	VZ22	 2013mm
	1160 TOYVZ	Hilux RN6 - LN65 1983 - 1985	L4 Cil. 2.0 L 2.5 L 2.8 L	8371089151	VZ12	 2150mm
ACELERADOR	103 TOYA	Hilux RN 50-55 1985 - 1988	0	7818089138	AC230	 585 mm
	3397 TOYAC	RN 85 Traccion 2R 1993-1997	2.4L 3.0L	7818035052 7818004040 7818035050 7818089154	AC50	 1020mm
	1606 TOYA	Hilux RN32, . Traccion 2R 1979 - 1983	L4 Cil. 2.2 L 2.4 L	7818089124	AC206	 708mm
	1608 TOYA	Hilux RN36 Traccion 4x4 1980 - 1983	L4 Cil. 2.2 L 2.4 L	7818095117	AC204	 647mm
	1370 TOYA	Hilux RN85 4x2 RN106 4x4 1992 -1999	L4 Cil. 2.4 L	7818035090	AC50	 590mm
APERTURA COFRE	277 TOYC	Hilux RN85 - RN106 - YN80-105 1992 -1999	V6 Cil. 2.7 L V8 Cil. 4.7 L	5363089114	CP9 Sin manija	 1873mm

TOYOTA - HILUX REVO 4x2



Tel. Multilínea (33) 3811 6917 - Serv. Cliente Cel. 33 1992 6768 - Guadalajara, Jalisco
Correo: Ventas@flexcontrol.com.mx - www.flexcontrol.com.mx - www.cablesnavcar.com

Automóvil - Suv - Van - Pickup - Camiones Pesados - Ligeros

IMPORTANTE. Evite devoluciones o reclamos. Identifique previamente: marca, modelo y año del vehículo. En caso de duda, **CONSULTE** a su asesor.

NUESTRA MISIÓN... Ser su aliado en el desarrollo y crecimiento de su negocio



Competimos directamente con los ORIGINALES

LINEA	CODIGO	MODELO	MOTOR	O.E.M	ARMADO	IMAGEN -- LONGITUD
FRENO DE MANO	4381 TOYFP	Hilux Revo 4x2 4x4 2016-2020	3.0 L	46410-0K120	FP527 Central	 1135mm
FRENO DE MANO	4348 TOYFP	Hilux Revo 4x2 4x4 2016-2020	2.4 L 3.0 L	46420-0K210	FP523 Trasero Derecho	 1395mm
FRENO DE MANO	4349 TOYFP	Hilux Revo 4x2 4x4 2016-2020	2.4 L 3.0 L	46430-0K210	FP524 Trasero Izquierdo	 2229mm

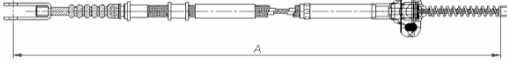
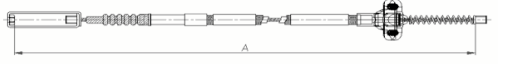

TOYOTA - HILUX Series SR

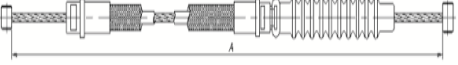
FRENO DE MANO	2596 TOYFP	Hilux SR/SR5 4x4 - 2006...	L4 Cil. 2.0 L 2.5 L 2.8 L	464300k041	FP201 Trasero Izquierdo	 2177mm
	2921 TOYFP	Hilux SR/SR5 4x4 2006...	L4 Cil. 2.0 L 2.5 L 2.8 L	464200k041	FP289 Trasero Derecho	 1365mm

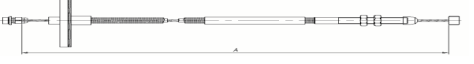
TOYOTA - HILUX Series YN

FRENO DE MANO	2917 TOYFP	Hilux YN50, 56, 57 1983-1998	L4 Cil. 2.0 L 2.5 L 2.8 L	4641035230	FP77 Principal	 1209mm
ACELERADOR	1049 TOYA	Hilux YN 80 1988...	L4 Cil. 2.4 L	7818089136	AC57	 1028mm
	1050 TOYA	Hilux YN 80-92-106 1988 - 1991	L4 Cil. 2.4 L	7818089157	AC49	 1583mm

TOYOTA - HILUX VIGO

FRENO DE MANO	3852 TOYFP	Vigo 4X4 KUN25 26 36 DIESEL 2005-2013	L4 Cil. 2.5 L 2.7 L 3.0 L	46410-0K040	FP392 Principal	 1260mm
	3880 TOYFP	Vigo 4X2 2006-2013	L4 Cil. 2.7 L	46420-0K030	FP395 Trasero Derecho	 1345mm
	3881 TOYFP	Vigo 4X2 2006 - 2013	L4 Cil. 2.7 L	46430-0K030	FP396 Trasero Izquierdo	 2182mm

TOYOTA - HIGHLANDER

SELECTOR CAMBIOS	4320 TOYSC	Highlander 2001- 2003	3.0 L	33820-48060	SC160	 1695mm
------------------	----------------------	--------------------------	-------	-------------	-------	--

Encino 1287 col. del Fresno Guadalajara Jal.

Tel. Multilínea (33) 3811 6917 - Servi-Cliente Cel. 33 1992 6768 - Guadalajara, Jalisco
Correo: ventas@flexcontrol.com.mx - www.flexcontrol.com.mx - www.cablesnavcar.com

Automóvil - Suv - Van - Pickup - Camiones Pesados - Ligeros

IMPORTANTE. Evite devoluciones o reclamos. Identifique previamente: marca, modelo y año del vehículo. En caso de duda, **CONSULTE** a su asesor.

NUESTRA MISIÓN... Ser su aliado en el desarrollo y crecimiento de su negocio

Competimos directamente con los ORIGINALES

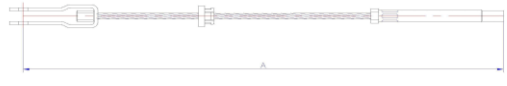
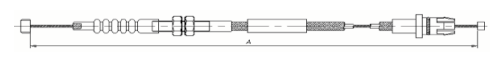
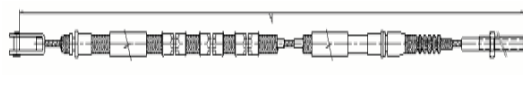
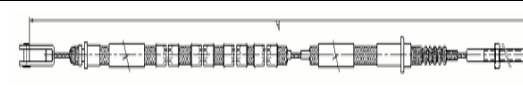
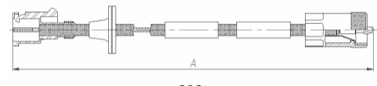
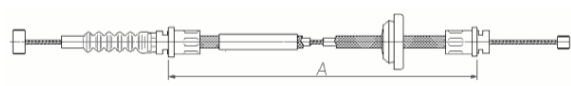
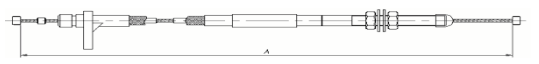
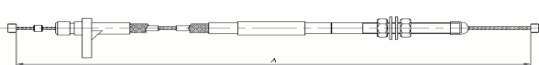
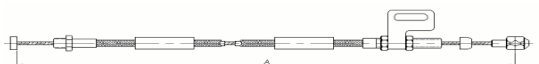
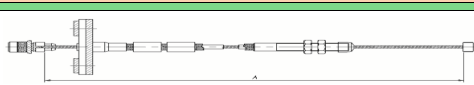
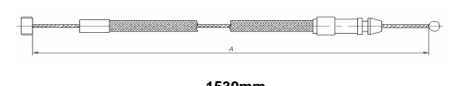
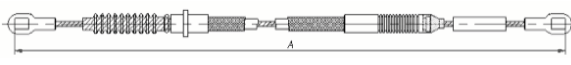







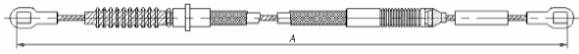

LINEA	CODIGO	MODELO	MOTOR	O.E.M	ARMADO	IMAGEN -- LONGITUD
TOYOTA - LAND CRUISER						
FRENO DE MANO	3758 TOYFP	Land Cruiser Base 1999-2007	V8 Cil. 4.7 L	4642060011	FP379 Trasero Derecho	 915mm
SOBREMARCHA	2310 TOYSB	Land Cruiser FJ62 -4FC, FJ70,73..4FC	0	3552060010	SB11	 1479mm
TOYOTA - LITEACE						
EMBRAGUE	248 TOYE	Liteace KM20 1979	L4 Cil. 1.6 L	3134029085	EM37	 2512mm
	947 TOYE	Liteace GLX KM36V 1988	L4 Cil. 1.6 L	3134027121	EM38	 2429mm
TOYOTA - PASEO						
VELOCIMETRO	2841 TOYVZ	Paseo 1987-1998	L4 Cil. 1.5 L	8371016200	VZ1	 898mm
TOYOTA - PICKUP TRUCK						
FRENO DE MANO	2736 TOYFP	Pickup Truck DRX, SR5 M/V6 1989-1995	V6 Cil. 3.0 L	4641035490	FP237 Principal	 1178mm
SOBREMARCHA	3830 TOYSB	Pickup Truck	L4 Cil. 2.4 L	0	SB15	 1517mm
	1274 TOSB	Pickup Truck T/A-340 1986-1996	L4 Cil. 2.4 L	3552035050	SB15	 1717mm
ACELERADOR	1481 TOYA	Pickup	L4 Cil. 2.4 L	7818089125	AC113	 698mm
TOYOTA - PRADO						
ACELERADOR	2933 TOYAC	Prado 1997...	0	7818035250	AC50	 896.874mm
APERTURA COFRE	3136 TOYCA	Prado todos 1999...	V6 Cil. 3.7 L V8 Cil. 4.7 L	5363060080	CP4	 1530mm
TOYOTA - PÚBLICA - 1000						
EMBRAGUE	560 TOYE	Pública KP30 2K 1969 - 1970	L4 Cil. 1.0 L 1.3 L	3134019085	EM35	 1563mm

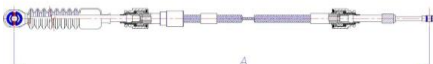
Automóvil - Suv - Van - Pickup - Camiones Pesados - Ligeros

IMPORTANTE. Evite devoluciones o reclamos. Identifique previamente: marca, modelo y año del vehículo. En caso de duda, **CONSULTE** a su asesor.

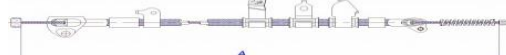
NUESTRA MISIÓN... Ser su aliado en el desarrollo y crecimiento de su negocio

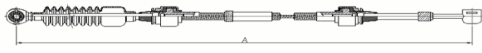
Competimos directamente con los ORIGINALES

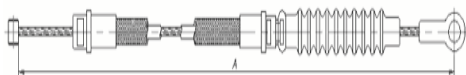
LINEA	CODIGO	MODELO	MOTOR	O.E.M	ARMADO	IMAGEN -- LONGITUD
EMBRAGUE	894 TOYE	1000 todos	L4 Cil. 1.0 L 1.3 L	3134019086	EM35	 1545mm
TOYOTA - RAV4						
SELECTOR CAMBIOS (Selector)	4098 TOYSC	RAV4 1994-2000 T/Estándar	2.0L	33821-42070	SC113	 1207mm
CONTROL CAMBIOS (Control)	4099 TOYCC	RAV4 1994-2000 T/Estándar	2.0L	33822-42030	CC101	 1147mm
FRENO DE MANO	3986 TOYFP	RAV4 2006-2011.	2.4L	464200R011 4642042130 464204211	FP418 Trasero Derecho	 1940mm
FRENO DE MANO	4260 TOYFP	RAV4 1998-2001	2.0L	46430-42020	FP495 Trasero Izquierdo	 1545mm
FRENO DE MANO	4261 TOYFP	RAV4 1998-2001	2.0L	46420-42010	FP496 Trasero Derecho	 1545mm
FRENO DE MANO	4264 TOYFP	RAV4 2006-2011	2.4L 2.5L 3.5L	464300R011 4643042130 4643042110	FP499 Trasero Izquierdo	 1982mm
APERTURA COFRE	3779 TOYCA	RAV4 2005-2012	V6 Cil. 3.7 L V8 Cil. 4.7 L	56630-0R010	CP9	 1793mm
TOYOTA - STARLET						
SELECTOR CAMBIOS (Selector)	1681 TOSE	Starlet 1988 - 1992 T/Standar	L4 Cil. 1.6 L	3382112470	SC8	 1203mm
	1682 TOSE	Starlet 1993 - 1997 T/Estándar	L4 Cil. 1.6 L 1.8 L	3382112301	SC8 Con pesa	 1185mm
TOYOTA - SUPRA						
SOBREMARCHA	1271 TOSB	Supra 2754 (SME) 1981	0	3552030030	SB11	 1246mm
TOYOTA - TACOMA						
	2422 TOYFP	Tacoma 1990-2006	L4 Cil. 2.7 L V6 Cil. 3.4 L	0	FP78 Principal	 1428mm

Automóvil - Suv - Van - Pickup - Camiones Pesados - Ligeros



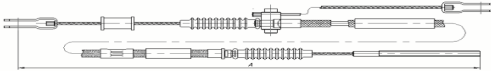
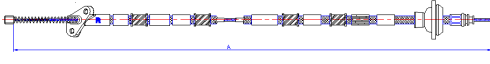
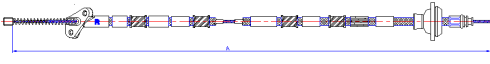
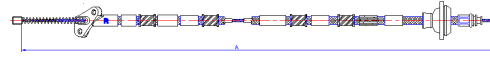
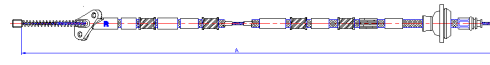
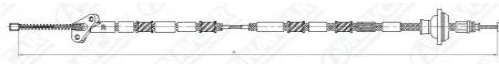
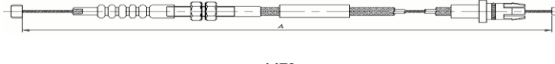
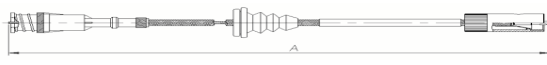

¡IMPORTANTE! Evite devoluciones o reclamos. Identifique previamente: marca, modelo y año del vehículo. En caso de duda, **CONSULTE** a su asesor.

NUESTRA MISIÓN... Ser su aliado en el desarrollo y crecimiento de su negocio

Competimos directamente con los ORIGINALES

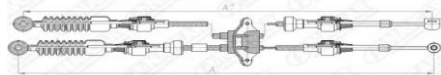
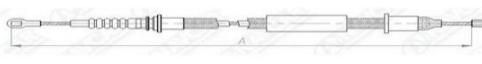
LINEA	CODIGO	MODELO	MOTOR	O.E.M	ARMADO	IMAGEN -- LONGITUD
FRENO DE MANO	3394 TOYFP	Tacoma 1995-2005	L4 Cil. 2.7 L V6 Cil. 3.4 L	4642035530 464235532 4642035542 4642035560	FP125 Trasero Único	 2821mm
	3733 TOYFP	Tacoma X-Runner, Pre Runner Gas; Base 2005 - 2014	L4 Cil. 2.7 L V6 Cil. 3.4 L	46430-04070	FP365 Trasero Izquierdo	 2505mm
	3735 TOYFP	Tacoma X-Runner, Pre Runner Gas; Base 2005 - 2014	L4 Cil. 2.7 L V6 Cil. 3.4 L	46420-04100	FP365 Trasero Derecho	 2488mm
	3736 TOYFP	Tacoma Base, Pre Runner - Gas 2005 - 2014	L4 Cil. 2.7 L V6 Cil. 3.4 L	46420-04080	FP365 Trasero Derecho	 2355mm
	3734 TOYFP	Tacoma X-Runner, Pre Runner, Base Gas 2005 - 2014	V6 Cil. 4.0 L	46420-04120	FP365 Trasero Derecho	 2745mm
FRENO DE MANO	3737 TOYFP	Tacoma Gasolina 2005 - 2014	4.0L	46420-04110	FP365 Trasero Derecho	 2771mm
SOBREMARCHA	2310 TOYSB	Tacoma 1995	0	3552060010	SB11	 1479mm
VELOCIMETRO	3566 TOYVZ	Tacoma 2006...	L4 Cil. 2.7 L V6 Cil. 3.4 L	0	VZ75 (92")	 2355mm

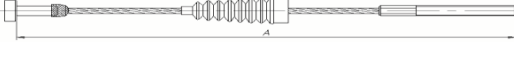
TOYOTA - TERCEL

KIT CONTROL Y SELECTOR CAMBIOS	2423 TOYCC	Tercel 1990 T/Standard	0	0	CC23	 A=1120mm/B=1086mm
EMBRAGUE	2512 TOYEM	Tercel 1983 - 1988	L4 Cil. 1.5 L	31410-16110	EM108	 976mm
	91 TOYE	Tercel AL11, todos los s 1982 - 1988	L4 Cil. 1.5 L	3134016110	EM40	 974mm
FRENO DE MANO	3371 TOYFP	Tercel EL51 1994...	L4 Cil. 1.5 L	4641016040	FP127 Principal	 261mm
VELOCIMETRO	2841 TOYVZ	Tercel CE, DX, DLX, EZ 1987-1998	L4 Cil. 1.5 L	8371016200	VZ1	 898mm
ACELERADOR	2351 TOYAC	Tercel E30 1986 - 1990	L4 Cil. 1.5 L	7818016160	AC190	 1162mm

Automóvil - Suv - Van - Pickup - Camiones Pesados - Ligeros

IMPORTANTE. Evite devoluciones o reclamos. Identifique previamente: marca, modelo y año del vehículo. En caso de duda, **CONSULTE** a su asesor.



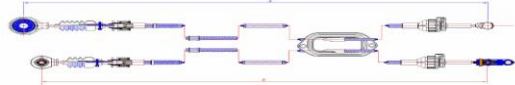

NUESTRA MISIÓN... Ser su aliado en el desarrollo y crecimiento de su negocio

Competimos directamente con los ORIGINALES



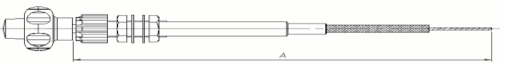

LINEA	CODIGO	MODELO	MOTOR	O.E.M	ARMADO	IMAGEN -- LONGITUD
TOYOTA - YARIS						
KIT CONTROL Y SELECTOR CAMBIOS	4253 TOYCC	Yaris 2006-2016	1.5L 4.0L	3382052440	CC122	 A=1131mm/B=1176mm

UNIVERSALES

UNIVERSALES - APERTURAS - AHOGADORES

ACELERADOR (Bernier)	1151 CHBA	MICROAJUSTE UNIVERSAL	0	2060507	AC131 (2.5 MTS)	 2590mm
	3836 CHBA	MICROAJUSTE UNIVERSAL	0	0	AC131 (3 MTS)	 3215mm
	3837 CHBA	MICROAJUSTE UNIVERSAL	0	0	AC131 (6 MTS)	 6215mm
	3838 CHBA	MICROAJUSTE UNIVERSAL	0	0	AC131 (10 MTS)	 10215mm

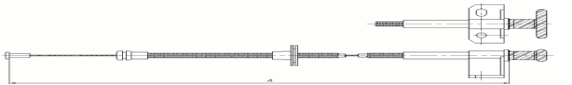
UNIVERSALES - APERTURAS - AHOGADORES

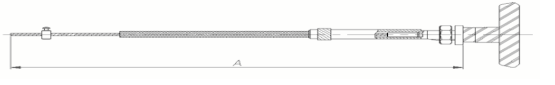
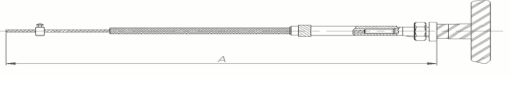
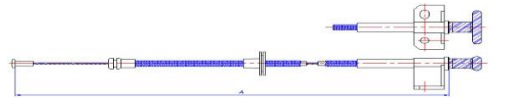







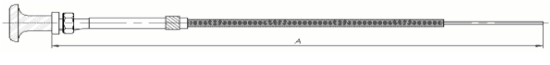
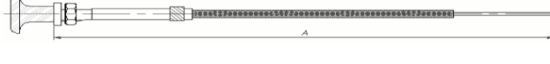

APERTURA COFRE	3938 FORCA	Serie F	0	0	CP33	 2150mm
	1098 CPUN	Universal	V6 Cil. 1.7 L V8 Cil. 4.7 L	0	CP13 (Con Soporte)	 2155mm
	1099 CPUN	Universal	V6 Cil. 1.7 L V8 Cil. 4.7 L	55024942	CP14 (Con Soporte)	 2130mm
	1100 CPUN	Universal	V6 Cil. 1.7 L V8 Cil. 4.7 L	0	CP10 (Con Soporte)	 2150mm
APERTURA COFRE	527 CPUN	Universal	V6 Cil. 5.7 L V8 Cil. 4.7 L	0	CP12 Cable Plastificado	 1700mm
	525 CPUN	Universal	V6 Cil. 5.7 V8 Cil. 4.7 L	0	CP12 Cable Plastificado	 2400mm
	4371 UNICA	Universal	0	0	CP14	 2670mm

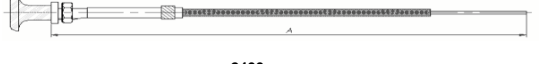
Automóvil - Suv - Van - Pickup - Camiones Pesados - Ligeros

IMPORTANTE. Evite devoluciones o reclamos. Identifique previamente: marca, modelo y año del vehículo. En caso de duda, **CONSULTE** a su asesor.

NUESTRA MISIÓN... Ser su aliado en el desarrollo y crecimiento de su negocio

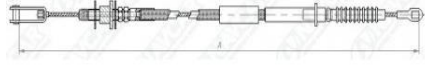
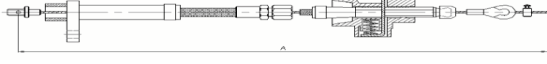
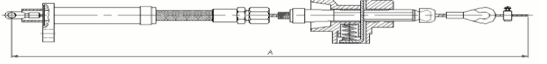
Competimos directamente con los ORIGINALES



LINEA	CODIGO	MODELO	MOTOR	O.E.M	ARMADO	IMAGEN -- LONGITUD
	272 CHUN	Universal	V6 Cil. 5.7 L V8 Cil. 4.7 L	0	CH1	 3400mm
	2479 CHOUN	Universal	V6 Cil. 5.7 L V8 Cil. 4.7 L	0	CH1	 1524mm
	526 CPUN	Universal	V6 Cil. 5.7 L V8 Cil. 4.7 L	0	CP12 Cable Plastificado	 3400mm
AHOGADOR	2164 CHOUN	Universal	0	0	CH1 Cable Rígido	 1830mm
	271 CHUN	Universal	0	0	CH1 Cable Rígido	 2400mm
	3966 UNIAP	PARO DE MOTOR TOMA DE FUERZA Camiones Americanos	0	0	AP11	 1525mm
TOMA DE FUERZA	3967 UNIAP	PARA DE MOTOR TOMA DE FUERZA	0	0	AP11	 3050 mm
	4148 UNIAP	PARO DE MOTOR TOMA DE FUERZA Camiones Americanos	0	0	AP13	 3260mm
	3968 UNIAP	PARA DE MOTOR TOMA DE FUERZA	0	0	AP11	 4575 mm
	3969 UNIAP	PARA DE MOTOR TOMA DE FUERZA	0	0	AP11	 5490 mm
UNIVERSALES - EMBRAGUE						
EMBRAGUE	2633 GMCEM	Gmc, Buick, Cadillac, Chevrolet Truck, Pontiac 1978-80	0	94027152	EM5 Ref tubo int Nylon	 1575mm
UNIVERSALES - SOBREMARCHAS - SOBREPASO						
SOBREMARCHA UNIV.	1367 SBUN	THM 125 700 4R Auto	0	0	SB18	 1255mm
	1368 SBUN	THM 200 -350	0	0	SB17	 1110mm
	1498 SBUN	General Motors Transmisión TH350 1970 - 1986	0	Código Universal K35955BU	SB16 Con Terminal metálico ranurado	 1030mm

Automóvil - Suv - Van - Pickup - Camiones Pesados - Ligeros



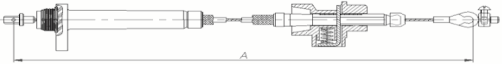
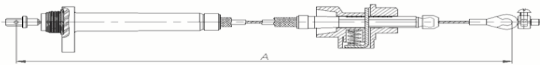

IMPORTANTE. Evite devoluciones o reclamos. Identifique previamente: marca, modelo y año del vehículo. En caso de duda, **CONSULTE** a su asesor.

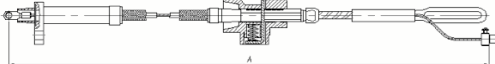
NUESTRA MISIÓN... Ser su aliado en el desarrollo y crecimiento de su negocio

Competimos directamente con los ORIGINALES



LINEA	CODIGO	MODELO	MOTOR	O.E.M	ARMADO	IMAGEN -- LONGITUD
SOBREMARCHA UNIV.	1499 SBUN	General Motors Transmisión TH125/700 - R4,6 1979 - 1991	0	Código Universal K65552U	SB8 Con Terminal metálico ranurado	 1520mm
	2432 GMCSU	General Motors Transmisión 200-4R, 700-R4 1978 - 1992	0	Código Universal K77978BU	SB8	 1189mm
	2037 GMCSB	GMC Camioneta universal 1988 - 1993	0	0	SB2	 1023mm
	1656 SBUN	General Motors THM 350 1980 - 1984	0	Código Universal K35951U	SB24	 1096mm

UNIVERSALES - VELOCIMETROS

VELOCIMETRO	697 GMCVZ	Chevrolet universal 1981...	0	0	VZ46	 1160mm
	2660 CHRVZ	Dodge universal 1971-1980	0	0	VZ82	 2559mm
	703 GMCVU	Universal	0	0	VZ2	 1560mm
	732 AMCVU	Jeep Wagoneer	V6 Cil. 4.0 L	0	VZ46 (81")	 2112mm

VOLKSWAGEN

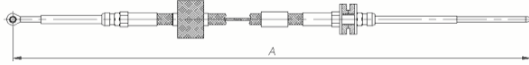
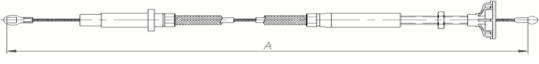
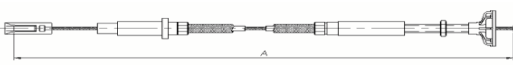
VOLKSWAGEN - ATLANTIC

SELECTOR CAMBIOS (Selector)	2301 VOLSC	Atlantic todos 1980-1984 T/Automtica	L4 Cil. 1.8 L	171713265C	SC16	 1535mm
EMBRAGUE	2293 VOLEM	Atlantic 1981-1987 T/Standar	L4 Cil. 1.6 L 1.7 L 1.8 L	171Z213335E	EM100	 795mm
	2562 VOLEM	Atlantic 1981...	L4 Cil. 1.6 L 1.7 L 1.8 L	171721335E	EM78	 794mm
ACELERADOR	2191 VOLAC	Atlantic Carburador BOCAR 1977-1979 T/Standar	L4 Cil. 1.6 L 1.7 L 1.8 L	531721555F	AC170 (corto)	 1025mm
ACELERADOR	1890 VOLAC	Atlantic 1980 - 1987 T/Stándar	L4 Cil. 1.6 L 1.7 L 1.8 L	171721555R 171721555T	AC80	 1048mm

VOLKSWAGEN - BRASILIA



EMBRAGUE	469 VOLE	Brasilia 1600	L4 Cil. 1.6 L 1.7 L 1.8 L	311721335A	EM53	 2340mm
----------	-------------	---------------	---------------------------	------------	------	--

Automóvil - Suv - Van - Pickup - Camiones Pesados - Ligeros



IMPORTANTE. Evite devoluciones o reclamos. Identifique previamente: marca, modelo y año del vehículo. En caso de duda, **CONSULTE** a su asesor.

NUESTRA MISIÓN... Ser su aliado en el desarrollo y crecimiento de su negocio



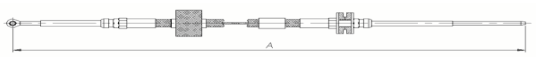
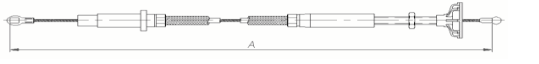
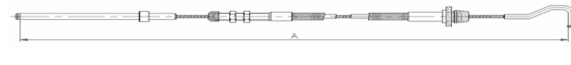
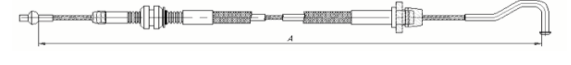

Competimos directamente con los ORIGINALES

LINEA	CODIGO	MODELO	MOTOR	O.E.M	ARMADO	IMAGEN -- LONGITUD
ACELERADOR	1882 VOLAC	Brasilia carbureador todos ...1978	L4 Cil. 1.6 L 1.7 L 1.8 L	102721555	AC88	 1978mm
	2189 VOLAC	Brasilia motor 1600 todos los s	L4 Cil. 1.6 L 1.7 L 1.8 L	102721555L	AC88	 2720mm

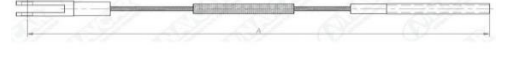

VOLKSWAGEN - CARIBE

SELECTOR CAMBIOS	2301 VOLSC	Caribe 1977-1984 T/Automatica	L4 Cil. 1.8 L	171713265C	SC16	 1535mm
EMBRAGUE	2293 VOLEM	Caribe 1981-1987	L4 Cil. 1.6 L 1.7 L 1.8 L	171Z213335E	EM100	 795mm
ACELERADOR	2191 VOLAC	Caribe Carburador BOCAR 1977-1979 T/Standar	L4 Cil. 1.6 L 1.7 L 1.8 L	531721555F	AC170 (corto)	 1025mm
	1890 VOLAC	Caribe 1980 - 1987 T/Standar	L4 Cil. 1.6 L 1.7 L 1.8 L	171721555R 171721555T	AC80	 1048mm
	3571 VOLAC	Caribe	L4 Cil. 1.6 L 1.7 L 1.8 L	171723555C	AC257	 995mm

VOLKSWAGEN - COMBI

EMBRAGUE	2920 VOLEM	Combi Transporter H4 1968-1971	L4 Cil. 1.5 L	2117213335E	EM55	 3190mm
ACELERADOR	1883 VOLAC	Combi 1956 - 1975	1.2 L 1.5 L	211721555A	AC88	 3612 mm
	1880 VOLAC	Combi Type II Transporter H4 1958 - 1965	L4 Cil. 1.5 L	111721555C	AC90	 2630mm
ACELERADOR	1725 VOLA	Combi Type I 1974 - 1979	L4 Cil. 1.5 L	133721555B	AC88	 2606mm
	2190 VOLAC	Combi Panel Engine 1600 ... 1990	L4 Cil. 1.5 L	211721555E	AC88	 3665mm

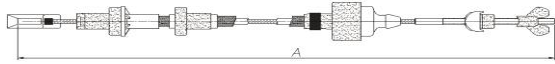
VOLKSWAGEN - GOL



EMBRAGUE	3548 VOLEM	Gol EFI 1997-2001.	L4 Cil. 1.0 L	377721335H	EM135	 865mm
	3547 VOLEM	Gol CFI, EFI, EFI Digital 1994-1998	L4 Cil. 1.6 L 1.8 L 2.0 L	377721335	EM138	 990mm

Automóvil - Suv - Van - Pickup - Camiones Pesados - Ligeros





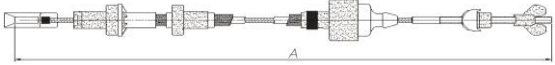

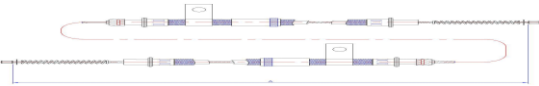

IMPORTANTE. Evite devoluciones o reclamos. Identifique previamente: marca, modelo y año del vehículo. En caso de duda, **CONSULTE** a su asesor.

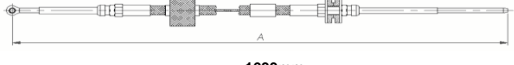
NUESTRA MISIÓN... Ser su aliado en el desarrollo y crecimiento de su negocio

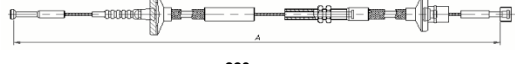
Competimos directamente con los ORIGINALES

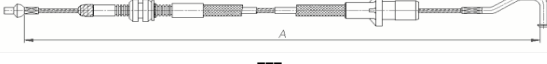
LINEA	CODIGO	MODELO	MOTOR	O.E.M	ARMADO	IMAGEN -- LONGITUD
	3549 VOLEM	Gol AP GIII EFI 1999-2002	L4 Cil. 1.6 L 1.8 L 2.0 L	377721335P	EM135	 976mm
FRENO DE MANO	2380 VOLFP	Gol 1995...	L4 Cil. 1.6 L 1.8 L 2.0 L	434951145	FP190	 1499mm
	3823 VOLFP	Gol GII, GIII, GTI 1994 - 2005 T/Standar	L4 Cil. 1.6 L 1.8 L 2.0 L	377609721	FP382 Trasero Unico	 2945mm

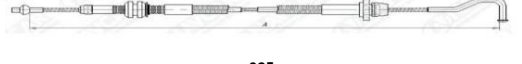
VOLKSWAGEN - GOLF

SELECTOR CAMBIOS	4026 VOLSC	Golf 1999-2003 T/Automatica	1.8 L 2.0 L	1J0713265A	SC99	 1174mm
SELECTOR CAMBIOS	1772 VOLSC	Golf 1985 - 1992 T/Automatica	L4 Cil. 1.8 L	191713265D/C 171713265D	SC16	 1633mm
EMBRAGUE	1746 VOLEM	Golf Diesel 1985 - 1989	L4 Cil. 1.6 L	191721335M	EM78	 810mm
	390 VOLE	Golf 1995...	L4 Cil. 2.0 L V6 Cil. 2.8 L	1H1721335A	EM54 (Ajuste manual)	 820mm
ACELERADOR	521 VOLA	Golf 1995...	0	1H0721255D	AC89	 1210mm
	2485 VOLAC	Golf Full inyection 1985 - 1990 T/Standar	L4 Cil. 1.5 L	191721555	AC171 (Corta)	 777mm
	2193 VOLAC	Golf 1988-92 T/Standar	L4 Cil. 1.5 L	0	AC80 (Largo)	 1027mm
ACELERADOR	2194 VOLAC	Golf 1988-1992	L4 Cil. 1.5 L	171721555B/J/H/P	AC171	 1050mm
	1632 VOLA	Golf 1994 - 1998	L4 ICil. 1.6 L 1.8 L	377.721.555C	AC80	 985mm
	521 VOLA	Golf 1995...	0	1H0721255D	AC89	 1210mm
	3300 VOLAC	Golf GTI 2000...	L4 Cil. 1.8 L 2.0 L	377721555N	AC80	 990mm

VOLKSWAGEN - JETTA

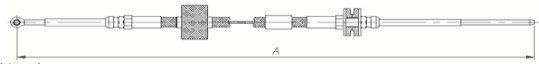







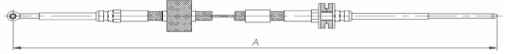

SELECTOR CAMBIOS	2301 VOLSC	Jetta 1980-1984 T/Automatica	L4 Cil. 1.8 L	171713265C	SC16	 1535mm
------------------	----------------------	------------------------------------	------------------	------------	------	--

Automóvil - Suv - Van - Pickup - Camiones Pesados - Ligeros

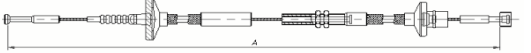
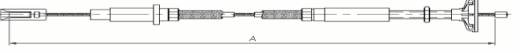

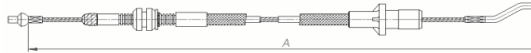
IMPORTANTE. Evite devoluciones o reclamos. Identifique previamente: marca, modelo y año del vehículo. En caso de duda, **CONSULTE** a su asesor.

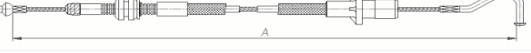
NUESTRA MISIÓN... Ser su aliado en el desarrollo y crecimiento de su negocio

Competimos directamente con los ORIGINALES

LINEA	CODIGO	MODELO	MOTOR	O.E.M	ARMADO	IMAGEN -- LONGITUD
NEUTRAL CAMBIOS	4026 VOLSC	Jetta 1999-2003 T/Automática	1.8 L 2.0 L	1J0713265A	SC99	 1174mm
SELECTOR CAMBIOS	4384 VOLCC	Jetta 1997-2007	1.8 L 1.9 L 2.0 L	1J0711265Q	CC144	 1268mm
SELECTOR CAMBIOS	1772 VOLSC	Jetta 1985 - 1992 T/Automática	L4 Cil. 1.8 L	191713265D/C / 171713265D	SC16	 1633mm
SELECTOR CAMBIOS	4379 VOLSC	Jetta A4 1997 - 2007 T/Estandar	1.8 L 1.9 L 2.0L	1J0711266E 1J0711266P 1K0711266AA 1K0711265AA	SC169	 1140mm
EMBRAGUE	1746 VOLEM	Jetta A2 Diesel 1987-1992	L4 Cil. 1.6 L	191721335M	EM78	 810mm
	390 VOLE	Jetta A3 1993-1999	L4 Cil. 2.0 L V6 Cil. 2.8 L	1H1721335A	EM54 (Ajuste manual)	 820mm
	2562 VOLEM	Jetta 1981-1989	L4 Cil. 1.6 L 1.7 L 1.8 L	171721335E	EM78	 794mm
FRENO DE MANO	3009 VOLFP	Jetta SOHC 1995	L4 Cil. 2.0 L	0	FP307 Trasero Derecho/Izquierdo	 1635mm
ACELERADOR	2485 VOLAC	Jetta Full inyection 1985 - 1990 T/Standar	L4 Cil. 1.5 L	191721555	AC171	 777mm
	2193 VOLAC	Jetta 1988-92 T/Stándar	L4 Cil. 1.5 L	0	AC80 (Largo)	 1027mm
	2194 VOLAC	Jetta A2 1988-1992 T/Stándar	L4 Cil. 1.5 L	171721555B/J/H/P	AC171	 1050mm
	3571 VOLAC	Jetta Sedan 2 y 4 Puertas SOHC 1980-1984	L4 Cil. 1.6 L 1.7 L 1.8 L	171723555C	AC257	 995mm

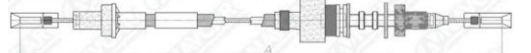
VOLKSWAGEN - POINTER

EMBRAGUE	3547 VOLEM	Pointer CFI, EFI, EFI 1997-1999	L4 Cil. 1.6 L 1.8 L 2.0 L	377721335	EM138 Horquilla	 990mm
	3549 VOLEM	Pointer GIII EFI 2000-2009	L4 Cil. 1.6 L 1.8 L 2.0 L	377721335P	EM135 Tornillo	 976mm
FRENO DE MANO	3823 VOLFP	Pointer 1997-2009	L4 Cil. 1.6 L 1.8 L 2.0 L	377609721	FP382 Trasero Único	 2945mm



Encino 1287 col. del Eresno Guadalajara Jal.

Automóvil - Suv - Van - Pickup - Camiones Pesados - Ligeros









IMPORTANTE. Evite devoluciones o reclamos. Identifique previamente: marca, modelo y año del vehículo. En caso de duda, **CONSULTE** a su asesor.

NUESTRA MISIÓN... Ser su aliado en el desarrollo y crecimiento de su negocio



Competimos directamente con los ORIGINALES

LINEA	CODIGO	MODELO	MOTOR	O.E.M	ARMADO	IMAGEN -- LONGITUD
ACELERADOR	3300 VOLAC	Pointer 1998-2000	1.8L 2.0L	377721555N	AC80	 990mm
ACELERADOR	4294 VOLAC	Pointer 1998-2008	1.8L 2.0L	377721555B	AC80	 1045mm

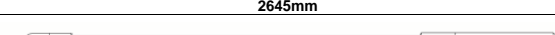
VOLKSWAGEN - SEDAN - (BOCHO)

EMBRAGUE	2271 VOLEM	Sedan 1200-1500 todos	4 Cil. 1.1 L 1.3 L 1.6 L	113721335Z	EM53	 2182mm
	2511 VOLEM	Sedan 1600 1994-2003	4 Cil. 1.1 L 1.3 L 1.6 L	111721335 111721335E	EM53	 2267mm
	285 VOLE	Sedan (Bocho)	4 Cil. 1.1 L 1.3 L 1.6 L	111721335C / E	EM53	 2300mm
	291 VOLE	sedan 1963-71	L4 Cil. 1.6 L	113721335A	EM53	 2265mm
	2786 VOLFP	Sedan (bocho) todos 1964-1967	4 Cil. 1.1 L 1.3 L 1.6 L	113609721K 113609721L	FP222 Trasero Izquierdo	 1757mm
VELOCIMETRO	988 VOLVZ	Sedan 1200, 1300, 1500 todos	4 Cil. 1.1 L 1.3 L 1.6 L	1139578012	VZ58	 1234mm
ACELERADOR	1880 VOLAC	Sedan Type I 1200	L4 Cil. 1.5 L	111721555C	AC90	 2630mm
	2187 VOLAC	Sedan motor 1500	4 Cil. 1.1 L 1.3 L 1.6 L	111721555E	AC88	 2632mm
	2188 VOLAC	Sedan Motor 1600	4 Cil. 1.1 L 1.3 L 1.6 L	112721555	AC88	 2645mm
ACELERADOR	387 VOLA	Sedan 1500	4 Cil. 1.1 L 1.3 L 1.6 L	111721555E	AC88	 2625mm

VOLKSWAGEN - VENTO







EMBRAGUE	390 VOLE	Vento 1995...	L4 Cil. 2.0 L V6 Cil. 2.8 L	1H1721335A	EM54	 820mm
FRENO DE MANO	2380 VOLFP	Vento 1995...	L4 Cil. 1.6 L 1.8 L 2.0 L	434951145	FP190Trasero Derecho/Izquierdo	 1499mm
ACELERADOR	521 VOLA	Vento 1995...	0	1H0721255D	AC89	 1210mm

Automóvil - Suv - Van - Pickup - Camiones Pesados - Ligeros

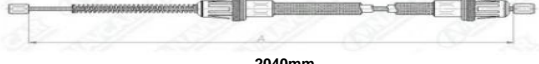
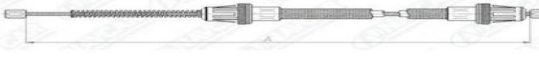
IMPORTANTE. Evite devoluciones o reclamos. Identifique previamente: marca, modelo y año del vehículo. En caso de duda, **CONSULTE** a su asesor.

NUESTRA MISIÓN... Ser su aliado en el desarrollo y crecimiento de su negocio

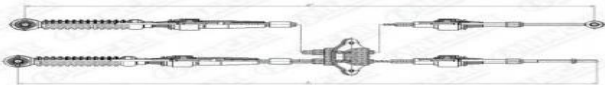
Competimos directamente con los ORIGINALES







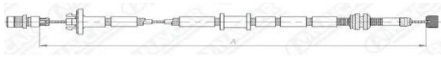

LINEA	CODIGO	MODELO	MOTOR	O.E.M	ARMADO	IMAGEN -- LONGITUD
ESPECIALES						
LÍNEA- CADILLAC						
CADILLAC - EL DORADO						
SOBREMARCHA	1614 GMSB	El Dorado 1980	0	25515164	SB2	 867mm
LÍNEA- CHEVROLET						
CHEVROLET - LLV						
FRENO DE MANO	2592 GMC FP	Truck LLV 1987- 1991	0	15568342	FP239 Trasero Derecho	 2040mm
	2593 GMC FP	Truck LLV 1987-1991	0	15568341	FP239 Trasero Izquierdo	 2152mm
	2594 GMC FP	Truck LLV 1992 - 1995	0	15674855	FP239 Trasero Izquierdo	 1528mm
CHEVROLET - CABALLERO						
SOBREMARCHA	1614 GMSB	Chevrolet Caballero 1984	0	25515164	SB2	 867mm
LÍNEA- FORD						
FORD - CAMTA						
APERTURA PUERTA	3793 FORAP	CAMTA 1992-98	0	0	ACH7	 574mm
LÍNEA- DAEWOO						
DAEWOO - MATIZ						
KIT SELECTOR Y CONTROL CAMBIOS	1667 DAES	Matiz 2001... T Estandar	0	96266622	CC10	 A=1046mm/B=1048mm
	1991 DAECC	Matiz 2002... T Estandar	0	96568385	CC11	 A=987mm/B=1076mm
ACELERADOR	1696 DAEA	Matiz 1998...	0	96316840	AC20	 1168mm

Automóvil - Suv - Van - Pickup - Camiones Pesados - Ligeros

IMPORTANTE. Evite devoluciones o reclamos. Identifique previamente: marca, modelo y año del vehículo. En caso de duda, **CONSULTE** a su asesor.

NUESTRA MISIÓN... Ser su aliado en el desarrollo y crecimiento de su negocio

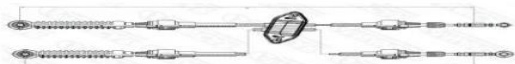
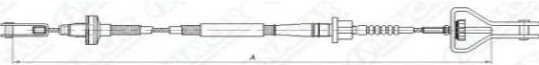
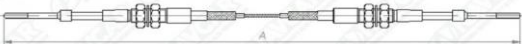
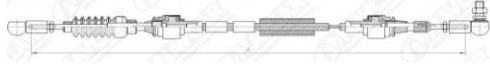
Competimos directamente con los ORIGINALES

LINEA	CODIGO	MODELO	MOTOR	O.E.M	ARMADO	IMAGEN -- LONGITUD
DAEWOO - GETZ						
ACELERADOR	2931 HYUAC	Getz 2007....	0	327901C900	AC198	 1508mm
DAEWOO - EXCEL						
KIT CONTROL Y SELECTOR CAMBIOS	1084 HYUC	Excel 1990 - 1995	0	4379424000	CC5	 A=1295mm/B=1312mm
EMBRAGUE	1407 HYUE	Excel 1989 - 1994	0	4151024003	EM51	 1406mm
	466 HYUE	Excel 1986	0	4151021010	EM51	 1272mm
EMBRAGUE	887 HYUE	Excel 1990...	0	4151024000	EM172 Ref tubo int Nylon	 1410mm
ACELERADOR	920 HYUA	Excel 93...	0	3279024000	AC83	 1136mm
DAEWOO - ELANTRA						
KIT SELECTOR Y NEUTRAL CAMBIOS	1086 HYUC	Elantra 1996 - 1999 T/Estándar	0	4379429010	CC5	 A=1175mm/B=1210mm
INFINITI - G20						
EMBRAGUE	3589 INFEM	G20 SR20 1991-1995	L4-2.0L	30770-62J10 30770-62J01	EM41	 749mm
INTERNATIONAL - VOLCO						
SELECTOR CAMBIOS	1212 INTV	Volco International Volqueta Hi 4700	0	GP85	CV2	 1833mm
INTERNATIONAL						
SELECTOR CAMBIOS	2964 INTCC	International 3100 4x2 Bus 2010	0	0	CC32	 1162mm
NEUTRAL CAMBIOS	2965 INTSC	International 3100 4x2 Bus 2010	0	0	SC47	 1504mm

Automóvil - Suv - Van - Pickup - Camiones Pesados - Ligeros

IMPORTANTE. Evite devoluciones o reclamos. Identifique previamente: marca, modelo y año del vehículo. En caso de duda, **CONSULTE** a su asesor.







NUESTRA MISIÓN... Ser su aliado en el desarrollo y crecimiento de su negocio

Competimos directamente con los ORIGINALES

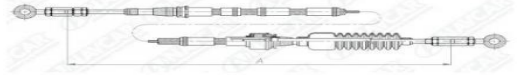
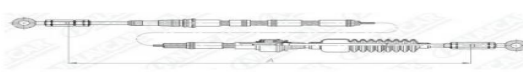
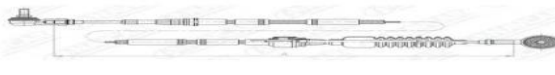

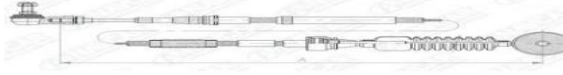
LINEA	CODIGO	MODELO	MOTOR	O.E.M	ARMADO	IMAGEN -- LONGITUD
-------	--------	--------	-------	-------	--------	--------------------

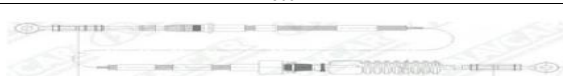
LÍNEA- ISUZU

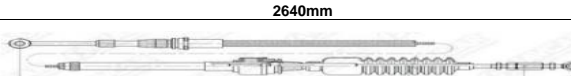
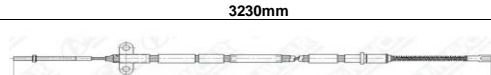
ISUZU - NPR

NEUTRAL CAMBIOS	2066 NPRSC	Npr Isuzu (Usa)	0	8970881850	SC21	 3038mm
	2420 NPRSC	Npr 2005...	0	8973504360 4CT2023	SC21	 2990mm
SELECTOR CAMBIOS	2065 NPRCC	Npr Isuzu (Usa)	0	8970881980	CC13	 3036 mm
	2419 NPRCC	Npr 2005...	0	8973504351 4CT2022	CC22	 2984mm
SELECTOR CAMBIOS	1080 NKRC	Nkr -Nhr 1998...	0	8970899863 4CT1296	CC1	 2515mm
	1081 NPRCC	Npr 1992 -1997	0	8970881950 4CT1154	CC66	 2960mm
NEUTRAL CAMBIOS	1082 NPRSC	Npr 1992- 1997	0	8970882040	SC86	 2962mm
	1125 NKRS	Nkr-Nhr 1998...	0	8970899872 4CT1301	SN2	 2640mm
SELECTOR CAMBIOS	2150 GMSCC	Npr (Usa) T/Automático	0	8971467211	SC34	 3230mm
FRENO DE MANO	3874 GMCFP	NHR Euro II 2011....	0	8982227220	FP171	 3730mm

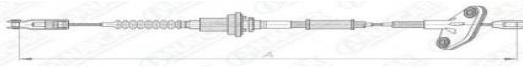
KIA - PICANTO

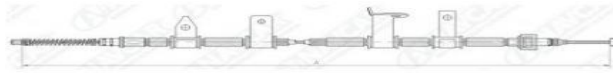



EMBRAGUE	2434 KIAEM	Picanto I 2004 - 2008	0	4151007100 4151007110 4151007120	EM105	 835mm
EMBRAGUE	3573 KIAEM	Picanto Ion 2012 - 2017	0	41510-1Y000	EM135	 826mm
FRENO DE MANO	3166 KIAFP	Picanto I Picanto Morning II 2004 - 2012	0	59770-07010	FP295 Trasero Derecho	 1395mm

Automóvil - Suv - Van - Pickup - Camiones Pesados - Ligeros

IMPORTANTE. Evite devoluciones o reclamos. Identifique previamente: marca, modelo y año del vehículo. En caso de duda, **CONSULTE** a su asesor.

NUESTRA MISIÓN... Ser su aliado en el desarrollo y crecimiento de su negocio

Competimos directamente con los ORIGINALES

LINEA	CODIGO	MODELO	MOTOR	O.E.M	ARMADO	IMAGEN -- LONGITUD
FRENO DE MANO	3167 KIAFP	Picanto I Picanto Morning II 2004 - 2012	0	59770-07010	FP295 Trasero Izquierdo	 3048mm
FRENO DE MANO	3523 KIAFP	Picanto Ion 2012 - 2017	0	597701Y400 59770-1Y000	FP295 Trasero Derecho	 1484mm
FRENO DE MANO	3524 KIAFP	Picanto Ion 2012 - 2017	0	597701Y400 59770-1Y000	FP295 Trasero Izquierdo	 1430mm
ACELERADOR	2459 KIAAC	Picanto I 2004 - 2008	0	3279007110 3279007100	AC211	 942mm
APERTURA COFRE	3014 KIACA	Picanto Morning 2007 - 2011	0	8119007100	CP4	 1128mm

KIA - K-2700

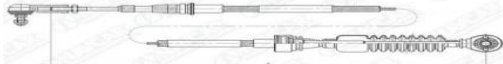
NEUTRAL CAMBIOS	1988 KIASC	K-2700 1997...,	0	0K60A46500	SC14	 2314mm
SELECTOR CAMBIOS	1989 KIAAC	K-2700 1997...,	0	0K60A46600	CC6	 2373mm

KIA - PREGIO

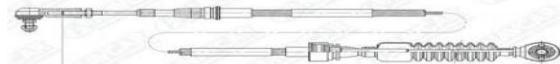

SELECTOR CAMBIOS	1122 KICC	Pregio 1998 - 1999	0	0K72B46500	CC6	 2235mm
---------------------	---------------------	-----------------------	---	------------	-----	--

LÍNEA- NISSAN

NISSAN - CEFIRO

ACELERADOR	2335 NISAC	Cefiro 1997...	0	1820144U00	AC165	 922mm
------------	----------------------	-------------------	---	------------	-------	---

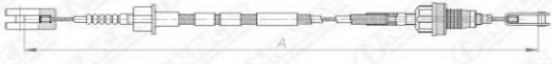
NISSAN - STANZA

EMBRAGUE	1803 NISEM	Stanza T11 1981-1985	0	30670D1201 30670D2801	EM88	 1000mm
ACELERADOR	2337 NISAC	Stanza KA24E 1990 - 1991	0	1820165	AC165	 1836mm

LÍNEA- RENAULT

RENAULT - TWINGO

Automóvil - Suv - Van - Pickup - Camiones Pesados - Ligeros

IMPORTANTE. Evite devoluciones o reclamos. Identifique previamente: marca, modelo y año del vehículo. En caso de duda, **CONSULTE** a su asesor.



NUESTRA MISIÓN... Ser su aliado en el desarrollo y crecimiento de su negocio

Competimos directamente con los ORIGINALES

LINEA	CODIGO	MODELO	MOTOR	O.E.M	ARMADO	IMAGEN -- LONGITUD
APERTURA COFRE	3385 RENCA	Twingo	0	8200207497 7700843484 7700843436	CP29	 1615mm

LÍNEA- TOYOTA

TOYOTA - HIJET

SELECTOR CAMBIOS	2184 TOYSC	Hijet Vans 1998-2006	0	3382087502	SC36	 834mm
SELECTOR CAMBIOS	2032 TOYSC	Dina	0	0	SC20	 2616mm
VELOCIMETRO	1847 TOVYZ	F Van	0	0	VZ12	 4016mm

LINEA AUTOMOTRIZ



CABLES DE CONTROL

PRODUCTOS **POLINAV** SUSPENSION



POLEAS TENSORAS

MANGUERAS PARA FRENO

